

OEM

N 940.5
TRANSLATION OF ORIGINAL OPERATING AND
INSTALLATION INSTRUCTIONS
ENGLISH

DIAPHRAGM VACUUM PUMP

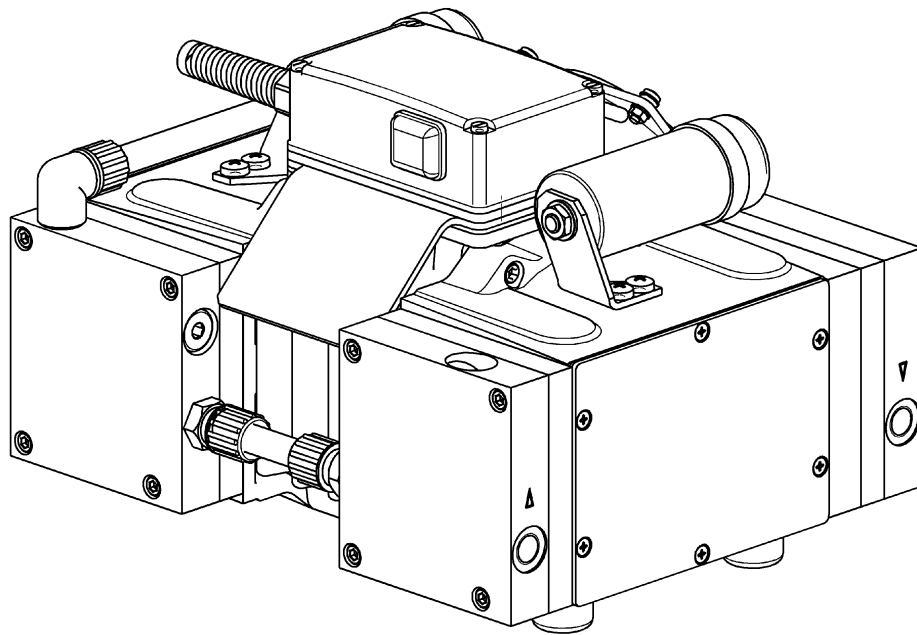

—
—
—

Note!

Before operating the pump and the accessories, please read the operating instructions on the web site (www.knf.com/downloads) and pay attention to the safety precautions!

KNF Neuberger GmbH
Alter Weg 3
D-79112 Freiburg
Germany
Tel. +49-(0)7664-5909-0
Fax +49-(0)7664-5909-99

E-mail: info@knf.de
www.knf.de

Contents	Page
1. About this Document	3
2. Use.....	4
3. Safety.....	5
4. Technical Data.....	7
5. Design and Function.....	10
6. Installation and Connection	13
7. Operation	16
8. Servicing	24
9. Troubleshooting	35
10. Spare Parts and Accessories	37
11. Returns	39

1. About this Document

1.1. Using the Operating and Installation Instructions

The Operating and Installation Instructions are part of the pump.

- Pass on the Operating and Installation Instructions to the next owner.

Project pumps

Customer-specific project pumps (pump models which begin with "PJ" or "PM") may differ from the Operating and Installation Instructions.

- For project pumps, also observe the agreed upon specifications.

1.2. Symbols and markings

Warning



WARNING

A danger warning is located here.

Possible consequences of a failure to observe the warning are specified here. The signal word, e.g.

Warning, indicates the danger level.

- Measures for avoiding the danger and its consequences are specified here.

Danger levels

Signal word	Meaning	Consequences if not observed
DANGER	warns of immediate danger	Death or serious injuries and/or serious damage are the consequence.
WARNING	warns of possible danger	Death or serious injuries and/or serious damage are possible.
CAUTION	warns of a possibly dangerous situation	Minor injuries or damage are possible.

Tab. 1

Other information and symbols

- An activity to be carried out (a step) is specified here.

1. The first step of an activity to be carried out is specified here. Additional, consecutively numbered steps follow.

i This symbol refers to important information.

2. Use

2.1. Proper use

The pumps are exclusively intended for transferring gases and vapors.

Owner's responsibility

Operating parameters and conditions

Only install and operate the pumps under the operating parameters and conditions described in chapter 4, Technical data.

Only complete pumps may be taken into service.

Make sure that the installation location is dry and the pump is protected against rain, splash, hose and drip water.

Requirements for transferred medium

Before using a medium, check whether the medium can be transferred danger-free in the specific application case.

Before using a medium, check the compatibility of the materials of the pump head, diaphragm and valves with the medium.

Only transfer gases which remain stable under the pressures and temperatures occurring in the pump.

2.2. Improper use

The pumps may not be operated in an explosive atmosphere.

The pumps are not suitable for transferring dusts.

The pumps are not suitable for transferring liquids.

The pumps must not be used to create vacuum and overpressure simultaneously.

An overpressure must not be applied to the suction side of the pump.

3. Safety

i Note the safety precautions in sections 6. *Installation and connection*, and 7. *Operation*.

The pumps are built according to the generally recognized rules of technology and in accordance with the occupational safety and accident prevention regulations. Nevertheless, dangers can result during their use which lead to injuries to the user or others, or to damage to the pump or other property.

Only use the pump when it is in a good technical and proper working order, in accordance with its intended use, observing the safety advice within the Operating and Installation Instructions, at all times.

Personnel	<p>Make sure that only trained and instructed personnel or specially trained personnel work on the pumps. This especially applies to assembly, connection and servicing work.</p> <p>Make sure that the personnel has read and understood the Operating and Installation Instructions, and in particular the "Safety" chapter.</p>
Working in a safety-conscious manner	Observe the accident prevention and safety regulations when performing any work on the pump and during operation.
Handling dangerous media	When transferring dangerous media, observe the safety regulations when handling these media.
Handling combustible media	<p>Be aware that the pumps are not designed to be explosion-proof.</p> <p>Make sure the temperature of the medium is always sufficiently below the ignition temperature of the medium, to avoid ignition or explosion. This also applies for unusual operational situations.</p> <p>Note that the temperature of the medium increases when the pump compresses the medium (compressor operation).</p> <p>Hence, make sure the temperature of the medium is sufficiently below the ignition temperature of the medium, even when it is compressed to the maximum permissible operating pressure of the pump. The maximum permissible operating pressure of the pump is stated in the technical specifications (chapter 4).</p> <p>If necessary, consider any external sources of energy, such as radiation, that may add heat to the medium.</p> <p>In case of doubt, consult the KNF customer service.</p>
Environmental protection	Store all replacement parts in a protected manner and dispose of them properly in accordance with the applicable environmental protection regulations. Observe the respective national and international regulations. This especially applies to parts contaminated with toxic substances.
EC Directives / Standards	For the purposes of the Machinery Directive 2006/42/EC, pumps are "partly completed machinery," and are therefore to be regarded as not ready for use. Partly completed machinery may not be commissioned until such time as it has been determined that the machine in which the partly completed machinery is to be assembled is in conformity with the provisions of the Machinery

Directive 2006/42/EC. The following essential requirements of Annex I of Directive 2006/42/EC (general principles) are applied and observed:

- General Principles No. 1
- No. 1.1.2. / 1.1.3. / 1.3.1. / 1.3.3. / 1.3.4. / 1.4.1. / 1.5.1. / 1.5.2. / 1.5.8. / 1.5.9. / 1.7.4. / 1.7.4.1. / 1.7.4.3.

As these partly completed machinery are OEM-models the power supplies and the equipment for disconnecting and switching-off the partly completed machinery respectively have to be considered when mounting as well as over-current and overload protective gear.

In addition a protection against mechanical parts in motion and hot parts, if existing, has to be provided when mounting.

The safety objectives of the following Directive(s) have been met:

- Directive 2014/35/EU on the harmonisation of the laws of Member States relating to electrical equipment designed for use within certain voltage limits in accordance with Annex I, No. 1.5.1. of the Directive 2006/42/EC.
- Directive 2011/65/EU on the restriction of the use of certain hazardous substances in electrical and electronic equipment (Annex II amended by Commission Delegated Directive (EU) 2015/863).

The following harmonized standards were taken as a basis:

N 940.5 APE, N 940.5 TTE	N 940.5 APE-W
EN IEC 55014-1/2	EN IEC 61000-6-2/3
EN IEC 61000-3-2	EN 61326-1
EN 61000-3-3	EN 60204-1
EN 60204-1	EN IEC 63000
EN IEC 63000	

Tab. 2

Customer service and repairs

Only have repairs to the pumps carried out by the KNF Customer Service responsible.

Use only genuine parts from KNF for servicing work.

4. Technical Data

Pump materials

N 940.5 APE

N 940.5 APE-W

Assembly	Material
Pump head	Aluminium
Diaphragm	EPDM
Valves, O-rings	EPDM
Pneumatic connections	PP/PTFE

Tab. 3

N 940.5 TTE

Assembly	Material
Pump head	PTFE/PVDF
Diaphragm	PFTE
Valves	FFPM
O-ring	FPM
Pneumatic connections	PVDF/PTFE

Tab. 4

Pneumatic values

N 940.5 APE

N 940.5 APE-W

Parameter	Value
Max. permissible operating pressure [bar g]	0.5
Ultimate vacuum [mbar abs.]	< 1.5
Delivery rate at atm. pressure [l/min]*	50

Tab. 5

*Liters in standard state (1,013 mbar)

N 940.5 TTE

Parameter	Value
Max. permissible operating pressure [bar g]	0.5
Ultimate vacuum [mbar abs.]	< 2
Delivery rate at atm. pressure [l/min]*	48

Tab. 6

*Liters in standard state (1,013 mbar)

Pneumatic Connections

Parameter	Value
Thread size	G ¼"

Tab. 7

Electrical data

N 940.5 APE

N 940.5 TTE

Parameter	Value			
Voltage	230 V	115 V	100 V	220 V
Frequency	50 Hz	60 Hz	50/60 Hz	60 Hz
Power consumption P ₁	250 W	250 W	250 W	250 W
Operating current	1.7 A	2.9 A	4.8 A	1.8 A
Maximum permitted mains voltage fluctuations	+/- 10 %	+/- 10 %	+/- 10 %	+/- 10 %
Protection class motor	IP54	IP54	IP54	IP54
Fuses (2x) T(A)	3.15	6.3	6.3	3.15

Tab. 8

N 940.5 APE-W

Parameter	Value
Voltage*	100-240 V
Frequency*	50-60 Hz
Power consumption	250 W
Operating current	2.8 A
Maximum permitted mains voltage fluctuations	+/-10%
Protection class of motor	IP 20

Tab. 9

* Automatic adaptation to mains power

The ac motor of the pumps N 940.5 APE and N 940.5 TTE is fitted as standard with a thermal-switch to protect against overloading.

Pump N 940.5 APE-W has electronic overload protection.

Other parameters

Parameter	Values
Permissible ambient temperature	+ 10 °C to + 40 °C
Permissible media temperature	+ 5 °C to + 40 °C
Weight N 940.5 APE [kg]	18.9
Weight N 940.5 APE-W [kg]	16.8
Weight N 940.5 TTE [kg]	18.6
Dimensions N 940.5 APE: L x H x W [mm]	295 x 203 x 240
Dimensions N 940.5 APE-W: L x H x W [mm]	270 x 185 x 246
Dimensions N 940.5 TTE: L x H x W [mm]	295 x 203 x 248
Maximum permissible ambient relative humidity	80 % for temperatures up to 31 °C, decreasing linearly to 50 % at 40 °C
Max. altitude of site [m above sea level]	2000

Tab. 10

Additional equipment

- a.) The pumps are equipped with a diaphragm-stabilization system that significantly increases the pumps' suction speed.
- b.) Adjustable flow rate is optional on pump N 940.5 APE-W. It works by altering motor speed either via a potentiometer or by external control via an analog signal input.

5. Design and Function

Design N 940.5 APE

- 1 On/off switch
- 2 Pump outlet
- 3 Pump inlet

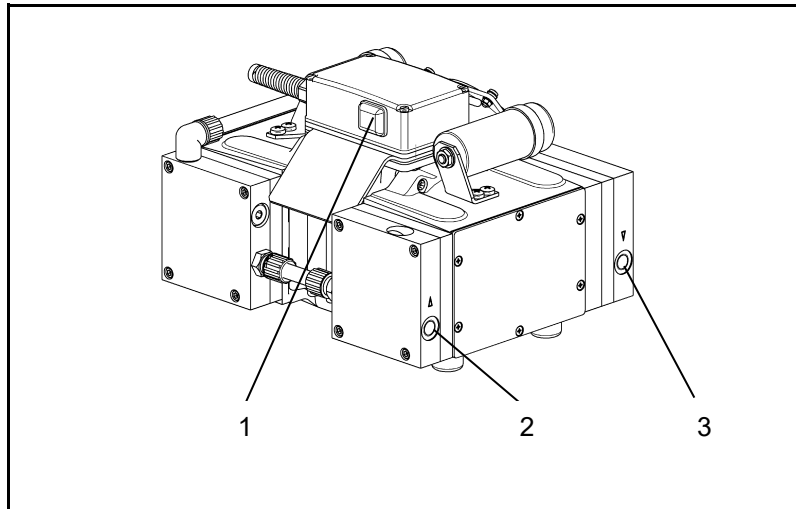

Fig. 1: Diaphragm pump N 940.5 APE

Design N 940.5 APE-W

- 1 Pump outlet
- 2 Pump inlet
- 3 On/off switch

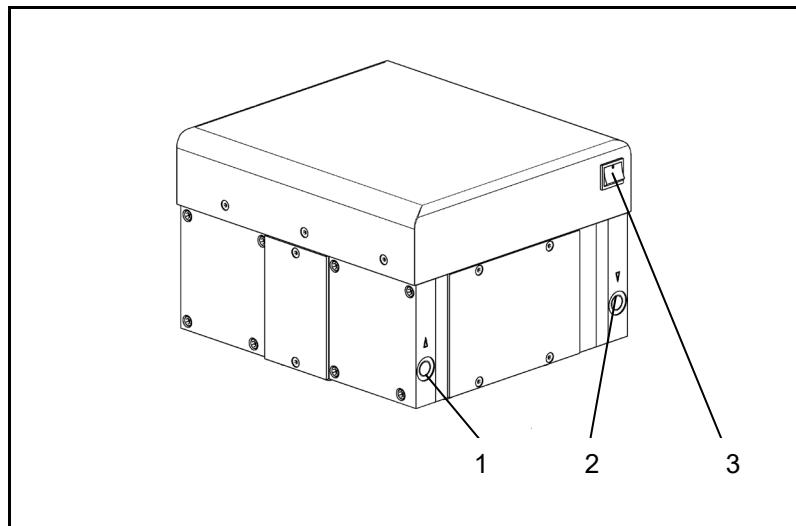

Fig. 2: Diaphragm pump N 940.5 APE-W

Design N 940.5 TTE

- 1 On/off switch
- 2 Pump outlet
- 3 Pump inlet

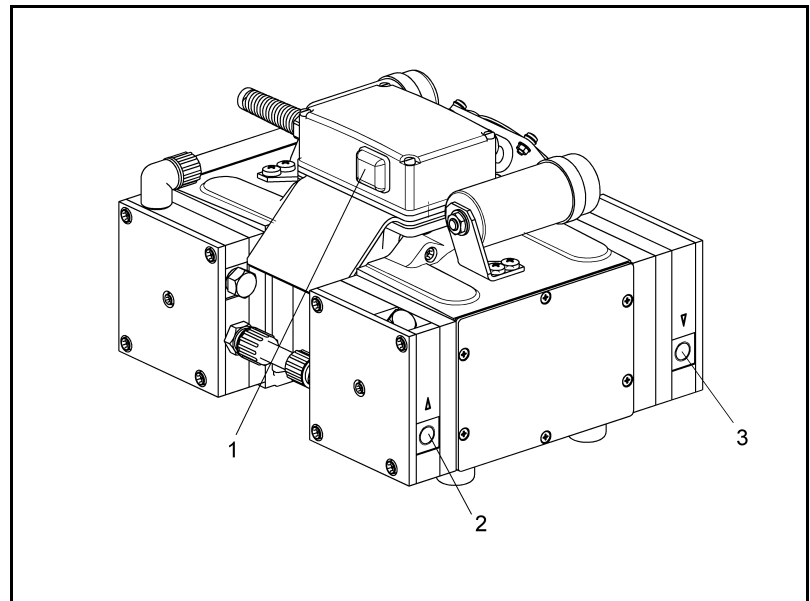

Fig. 3: Diaphragm pump N 940.5 TTE

Function Diaphragm Pump

- 1 Outlet valve
- 2 Inlet valve
- 3 Transfer chamber
- 4 Diaphragm
- 5 Eccentric
- 6 Connecting rod
- 7 Pump drive

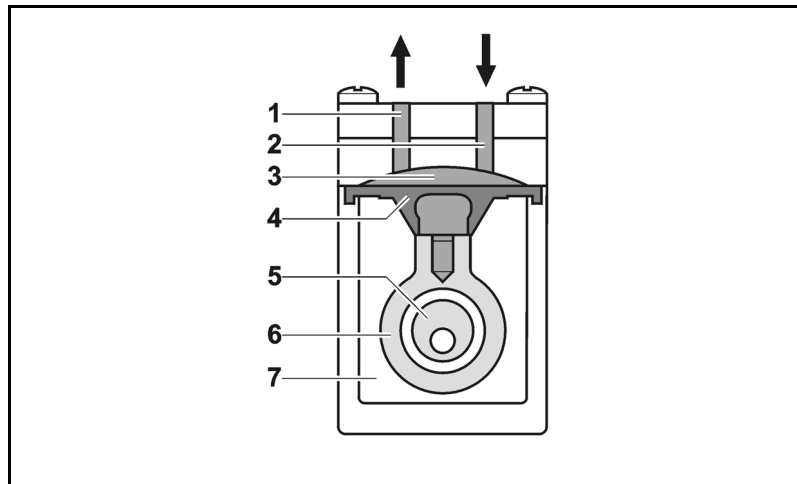

Fig. 4: Pump head

Diaphragm pumps transfer, compress (depending on pump version) and evacuate gases and vapors.

The elastic diaphragm (4) is moved up and down by the eccentric (5) and the connecting rod (6). In the downward stroke it aspirates the gas to be transferred via the inlet valve (2). In the upward stroke, the diaphragm presses the medium out of the pump head via the outlet valve (1). The transfer chamber (3) is hermetically separated from the pump drive (7) by the diaphragm.

Function Diaphragm Stabilization System

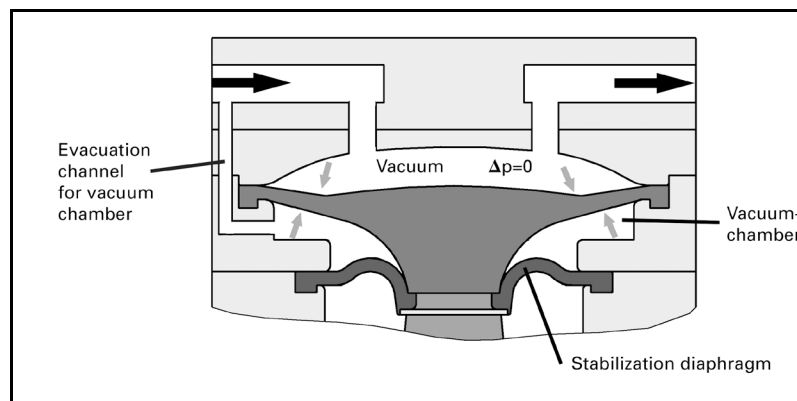

Fig. 5: Function of diaphragm stabilization system

An additional diaphragm, the so-called stabilization diaphragm, separates the underside of the working diaphragm from the "crank" space of the pump (see Fig. 5). The space between the two diaphragms (called a vacuum chamber) is connected with the suction side of the pump via an balancing connection. This way, the vacuum chamber has approximately the same pressure as the working space of the diaphragm pump. The pressure difference between the upper and underside of the diaphragm approaches zero. The working diaphragm remains stable, independent of the inlet pressure of the pump. This improves the suction speed of the pump significantly, over its entire working range.

6. Installation and Connection

Only install the pumps under the operating parameters and conditions described in chapter 4, Technical data.

Observe the safety precautions (see chapter 3).

6.1. Installation of the pump

→ Before installation, store the pump at the installation location to bring it up to ambient temperature.

Dimensions → For the mounting dimensions see Fig. 6 (N 940.5 APE), Fig. 7 (N 940.5 APE-W) or Fig. 8 (N 940.5 TTE).

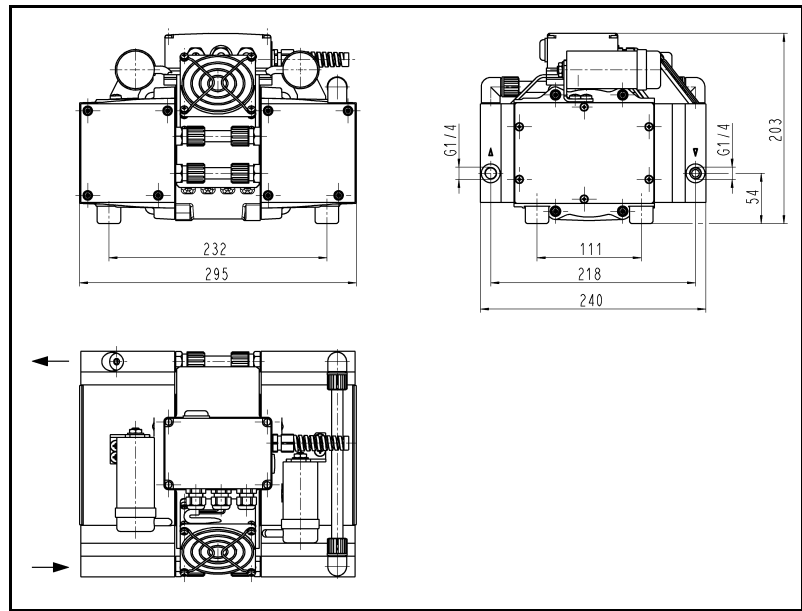

Fig. 6: Dimensions N 940.5 APE
(Dimensional tolerances conform to DIN ISO 2768-1, Tolerance Class V)

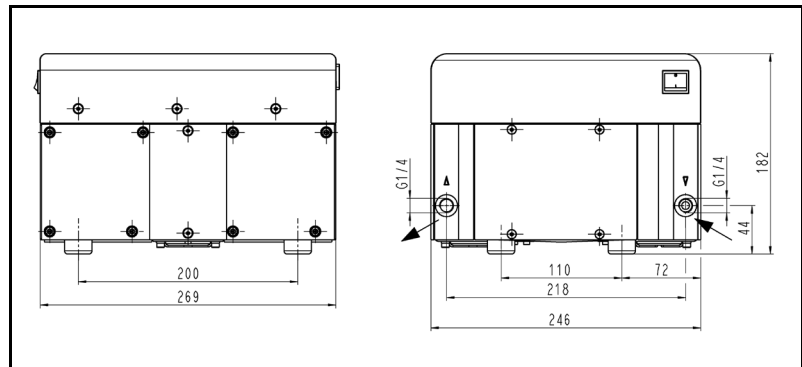

Fig. 7: Dimensions N 940.5 APE-W
(Dimensional tolerances conform to DIN ISO 2768-1, Tolerance Class V)

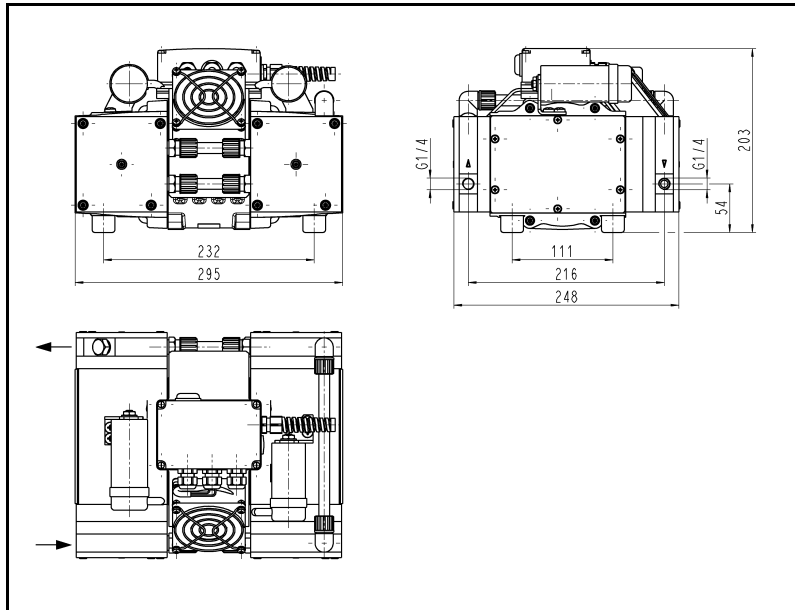

Fig. 8: Dimensions N 940.5 TTE
(Dimensional tolerances conform to DIN ISO 2768-1, Tolerance Class V)

- Cooling air supply → Install the pump so that the motor fan can intake sufficient cooling air.
- Installation location → Make sure that the installation location is dry and the pump is protected against rain, splash, hose and drip water.
 - Pump N 940.5 APE-W: Place the pump only on a solid foundation in order to ensure that the ventilators will work properly.
 - Install the pump at the highest point in the system to prevent condensate from collecting in the pump head.
 - Protect the pump from dust.
 - Protect the pump from vibrations and jolts.
- Mounting Each pump stands on four rubber feet.
 - If you choose to fasten a pump to the foundation you must first unscrew the rubber feet. The pump can then be bolted to the foundation by means of the four boreholes (M6 threads) that are now exposed.

6.2. Electrical connection



DANGER

- Extreme danger from electrical shock
 - Only have the pump connected by an authorized specialist.
 - Only have the pump connected when the power supply is disconnected.

When connecting the device to a power source, the relevant standards, directives, regulations, and technical standards must be observed.

Connecting pump

1. Compare the supply data with the data on the motor-plate.

i The voltage must not vary by more than + 10 % and - 10 % from that shown on the type-plate.

2. Insert the power cable plug into a properly installed shockproof socket.

6.3. Pneumatic connection

Connected components

- ➔ Only connect components to the pump which are designed for the pneumatic data of the pump (see chapter 4, Technical data).

Pump exhaust

- ➔ If the pump is used as a vacuum pump, safely discharge the pump exhaust at the pump's pneumatic outlet.

Connecting pump

i A marking on the pump head shows the direction of flow.

1. Remove the protective plugs from the hose connection threads.
2. The accessories silencer or hose connectors (where applicable) are screwed into the port threads.

i The silencer is to be mounted on the suction side or pressure side of the pump head. With multiple-head pumps, this relates to the first pump head or last pump head.

3. Connect the suction line and pressure line (thread size G 1/4).
4. Lay the suction and pressure line at a downward angle to prevent condensate from running into the pump.

7. Operation

7.1. General

- Only operate the pumps under the operating parameters and conditions described in chapter 4, Technical data.
- Make sure the pumps are used properly (see section 2.1).
- Make sure the pumps are not used improperly (see section 2.2).
- Observe the safety precautions (see chapter 3).
- The pumps are intended for installation. Before putting them into service it must be established that machinery or equipment in which they are installed meets the relevant regulations.



WARNING

Hazard of the pump head bursting due to excessive pressure and temperature increase

- Do not exceed max. permissible operating pressure (see chapter 4, Technical data).
- Monitor pressure during operation.
- If the pressure exceeds the maximum permissible operating pressure, immediately shut down pump and eliminate fault (see chapter 9. Troubleshooting).
- Only throttle or regulate the air or gas quantity in the suction line to prevent the maximum permissible operating pressure from being exceeded.
- If the air or gas quantity in the pressure line is throttled or regulated, make sure that the maximum permissible operating pressure is not exceeded.

i Excessive pressure (with all of the related hazards) can be prevented by placing a bypass line with a pressure-relief valve between the pressure and suction sides of the pump. For further information, contact our technical adviser (see front page for telephone number).

Pump standstill → With the pump at a standstill, open pressure and suction lines to normal atmospheric pressure.

Thermal switch When the operation of the pump is interrupted by the thermal switch (N 940.5 APE and N 940.5 TTE) or the electronics (N 940.5 APE-W), the pump will restart automatically after cooling down.

→ Take all necessary care to prevent this leading to a dangerous situation.

Silencer Change the silencer (accessory) if it is dirty.

Switching on and off → Switching the pump on and off with the mains switch (see Fig. 1 (N 940.5 APE), Fig. 2 (N 940.5 APE-W) or Fig. 3 (N 940.5 TTE) in chapter 5).

i N 940.5 APE-W:

Depending on the level of the applied electrical voltage, initialization of the electronics can take up to one second before the pump starts.

i The pump may not start up against pressure during switch-on. This also applies in operation following a brief power failure. If a pump starts against pressure, it may block. This activates the thermal switch or pump electronics, and the pump switches off.

→ Make sure that normal atmospheric pressure is present in the lines during switch-on.

Adjusting the flow rate

N 940.5 APE, N 940.5 TTE and N 940.5 APE-W

The flow rate cannot be varied.

N 940.5 APE-W with Potentiometer (special design)

The pump's speed can be varied between around 500 and 1,500 RPM, via the potentiometer at the front side of the pump. The flow rate can be adjusted this way.

7.2. Control (optional for pumps with brushless DC motor)

- Control cable and Level-Translator, see accessories p. 37
- Control pin assignments, see Fig. 9, S.18

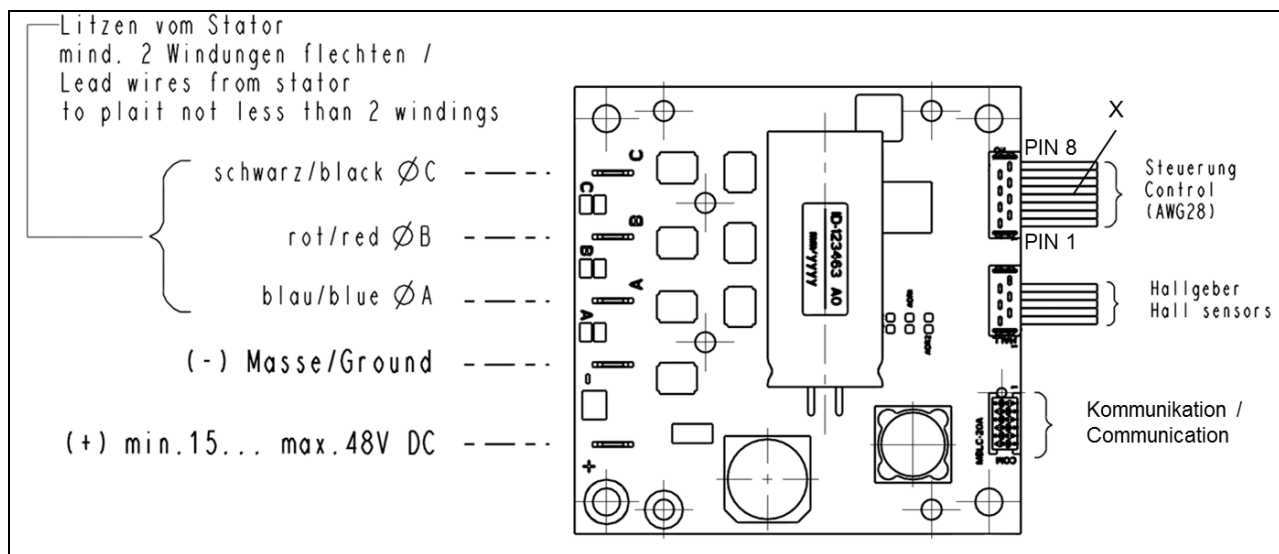

Pin Nr. Pin No.	Farbkodierung Color coding	Benennung Description	Elektrische Eigenschaft Electrical characteristic	
1	schwarz black	DC Spannungsquelle DC power supply	$U_{0-DC}: 5\pm 0.2V$ $I_0: \text{max. } 170mA$	
2	weiß white	Eingang Steuerspannung Control voltage input	$U_{IN-DC}: 0...5V$ ($P_{IN-MAX}: \leq 5mW$) $f_{PWM-IN}: 100Hz\pm 50Hz$ duty cycle: 0...100% $R_{IN} \geq 13.6k\Omega @ 1kHz$	
3*	grau grey	Masse Ground		
4	lila purple	Ausgang Fehlermeldung Error signal output	$U_{ERROR-0-DC}: \leq 0.6V / U_{ERROR-1-DC}: \geq 4.5V...U_{0-DC}$	
5*	blau blue	Masse Ground	$U_{ON-DC}: \leq 0.9V$ $U_{OFF-DC}: \geq 4.2V...U_{0-DC}$	
6	grün green	Eingang Remote EIN/AUS Input Remote ON/OFF		
7	gelb yellow	Ausgang Drehzahlsignal Speed signal output	PWM-OUT $f_{PWM-OUT}: 50Hz$ $U_{PWMF-OUT}: U_{0-DC}$ duty cycle: 0...100%	FREQ-OUT $f_{FREQ-OUT}: n$ 1 pulse / revolution $U_{FREQ-OUT}: U_{0-DC}$
8*	orange orange	Masse Ground		
Zulässige Spannung an den Steuereingängen allowable voltage at control inputs			$U_{DC}: \text{max. } 5.5V$	
Zulässige Strombelastbarkeit an den Steuerausgängen allowable ampacity at control outputs			$I: \text{max. } 10mA$	

Fig. 9: Control cable pin assignments

* Ground Pin 3, 4 and 7 are connected with each other

** further control voltage versions on demand

i If Pin 1 is simultaneously used as control voltage specification for Pin 2, please contact the KNF customer services (see last page for contact data).

7.2.1. Speed control

The motor drives the pump at a changeable speed between n_{\min} and n_{\max} . Speed is specified via the control voltage.

7.2.1.1. Speed input

Speed range The speed range of $n_{\min} \dots n_{\max}$ is shown scaled to the control voltage U_c :

- $U_{c\min}$: 0.1V
- $U_{c\max}$: 5.0V

If the control voltage is less than $U_{c\min}$, the motor is OFF.

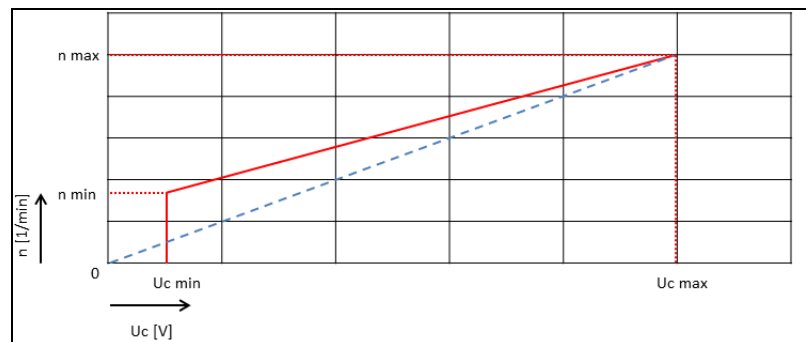

Fig. 10: Control-voltage/speed curve (standard)

Speed specification Speed is specified through the 8-pin controller connection, Pin 2 (see Table in Fig. 9).

Optional analog settings for control voltage input

The following additional settings can be made at the factory upon request:

- Modify control voltage values $U_{c\min}$ and $U_{c\max}$
- If the control voltage is less than $U_{c\min}$ the motor will be ON.

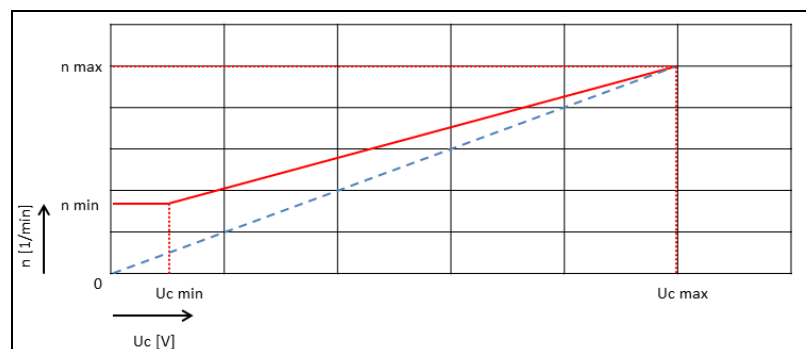

Fig. 11: Scaled control-voltage/speed curve (optional)

7.2.1.2. Speed output

Speed output Speed is outputted through the 8-pin controller connection (Pin 8, see Table in Fig. 9)

The motor controller generates speed-synchronized pulse-width modulation (see Fig 12).

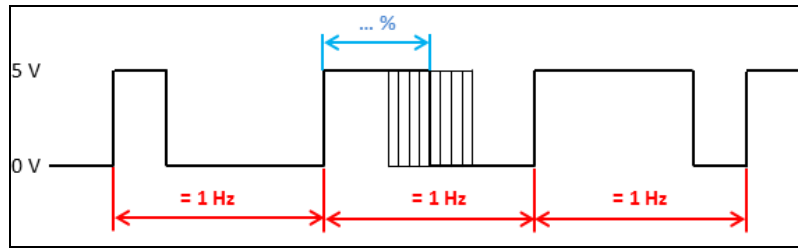

Fig 12: Analog speed output (standard)

Optional speed output

The motor controller generates a speed-synchronized right-angle frequency with 5V TTL level (see Fig. 13).

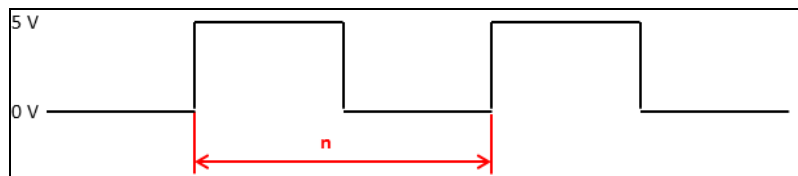

Fig. 13: Digital speed output (optional)

7.2.2. Remote ON/OFF

Remote ON/OFF

Remote ON/OFF is through an 8-pin controller connection (Pin 5, see Fig. 9).

i To start the motor, Pin 5 must be bridged to the ground of the controller connection.

External activation

7.2.3. External digital activation (optional)

If desired, the pump motor can be activated externally. This requires a special setting at the factory (see final page for contact data).

External activation is through the 6-pin communication connection (see Fig. 9 above).

Connector type: Micro-Match Female Top Entry

Part. no.: 7-215079-6

i When the motor is activated externally, the control inputs are inactive.

Connection communication plug (see Fig. 9 top)

- PIN 1 – do not connect
- PIN 2 – do not connect
- PIN 3 – GND
- PIN 4 – 5V (max. 50mA)
- PIN 5 – TX MBLC
- PIN 6 – RX MBLC

Motor connection options – external control unit

Fig. 14: External activation options (optional)

The following motor functions can be controlled:

- Motor remote ON/OFF
In the factory condition, the motor is OFF when operating voltage is applied. However, as an option the motor can be ON when operating voltage is applied.
- Motor speed
Setting motor speed within speed limits n_{min} and n_{max} .
- Read-out of the following process parameters:
 - Actual/Nominal motor speed
 - Control limits of motor speed
 - Operating current of the motor
 - Temperature of the motor controller
 - Fault status
 - Software version number

Interface protocol The connection between the PC and motor controller can be operated as an RS-232 interface. Accordingly, in the operating system it is managed as an additional COM connection and can be addressed with conventional terminal software.

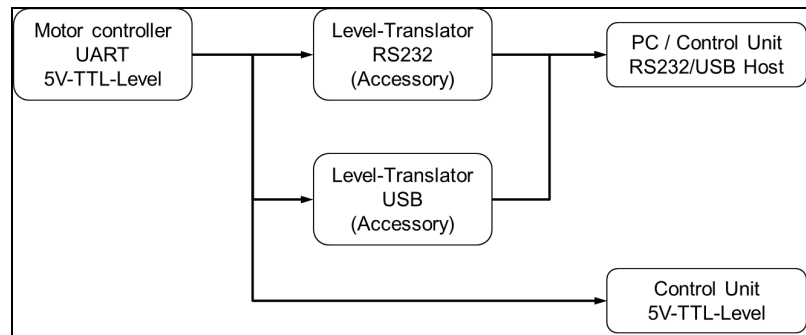
Interface configuration

- Baud rate: 57600 bits/s
- Data bits: 8
- Parity: none
- Stop bits: 1
- Flow control: none

Tables Tab. 11 to Tab. 13 contain the necessary command sets, shown as ASCII characters. When transmitting, the commands must be followed by ASCII character <CR> (carriage return, decimal value 013). The underlined expressions are not characters, but symbols as explained in table 7.

Parameter	Command*	Function	Reply
Motor	dB	Start	<u>S</u> ; <u>E</u>
	dE	Stop	<u>S</u> ; <u>E</u>
Speed	dSnnnn [nnnn = speed value]	Set nominal speed	<u>ns</u> ; <u>E</u>

Tab. 11: Control commands

*A pause of at least 25 ms is required after the “dB” instruction set.

Parameter	Command	Reply
Actual motor speed; operating current of the motor; temperature of the motor controller; Fault status	pP	<u>ni</u> ; <u>ii</u> ; <u>ti</u> ; <u>ei</u> ; <u>E</u>
Fault status (single value)	gP	<u>ei</u> ; <u>E</u>
Nominal motor speed	gS	<u>ns</u> ; <u>E</u>
Minimum possible motor speed	gSl	<u>nl</u> ; <u>E</u>
Maximum possible motor speed	gSh	<u>nh</u> ; <u>E</u>
Software version number	iV	<u>V</u> ; <u>E</u>

Tab. 12: Read commands

Symbol	Function	Meaning
<u>E</u>	Announcement of completion	0 command cannot be completed
		1 command completed
		? command unclear
<u>S</u>	Status message	For service only
<u>V</u>	Version number	e.g. 01.018
<u>ni</u>	Actual motor speed	Value [min ⁻¹]
<u>ns</u>	Nominal motor speed	Value [min ⁻¹]
<u>nl</u>	Minimum nominal motor speed	Value [min ⁻¹]
<u>nh</u>	Maximum nominal motor speed	Value [min ⁻¹]
<u>ii</u>	operating current of the motor	Value [mA]
<u>ti</u>	temperature of the motor controller	Value [°C]
<u>ei</u>	Fault status	16 bit value

Tab. 13: Symbols

The symbols represent the ASCII codes of sequences of digits any length. The controller processes input values only as whole numbers (integers).

Interface level

i See p. 18 for pin assignment of the motor controller's communication plug.

Parameter	Value
Rx KNF MBLC	Low: 0V...0.9V High: 4.2V...5.2V
Tx KNF MBLC	Low: 0V...0.6V High: 4.5V...5.2V

Tab. 14

8. Servicing

8.1. Servicing schedule

Component	Servicing interval
Pump	Regular inspection for external damage or leaks
Diaphragms and valve plates	Replace at the latest, when pump output decreases

Tab. 15

8.2. Cleaning

i When cleaning, make sure that no liquids enter the inside of the housing.

8.2.1. Flushing pump

For pump N940.5 TTE:

➔ KNF recommends: When transferring aggressive media, flush the pump under atmospheric conditions some minutes with air (or, if necessary for safety reasons, with an inert gas) prior to switch-off to increase the service life of the diaphragm.

8.2.2. Cleaning pump

➔ Only use solvents for cleaning if the head materials cannot be attacked (check the resistance of the material!).

➔ If compressed air is available, blow out the components.

8.3. Replacing diaphragms and valve plates

8.3.1. N 940.5 APE and N 940.5 APE-W

- Conditions
- Motor disconnected from mains and de-energized
 - Pump clean and free of dangerous substances

Spare parts

Spare part*	Position	Quantity
Diaphragm	(7) in Fig. 17, (6) in Fig. 20	4
Valve plate	(3) in Fig. 17 and Fig. 20	8
O-ring d 32 mm	(4) in Fig. 17 and Fig. 20	8
O-ring d 26 mm	(5) in Fig. 17	2
O-ring d 5.5 mm	(8) in Fig. 17	2

Tab. 16

* According to Spare parts list, chapter 10

Tools and material

Anz.	Tools/material
1	Allen key 4 mm
1	Phillips screwdriver No. 1*
1	Phillips screwdriver No. 2*
1	Small screwdriver
1	Pair of pliers
1	Felt-tip pen

Tab. 17

* only for pump type N 940.5 APE-W

Information on procedure

- ➔ Always replace the valve plates and diaphragms together to maintain the pump performance.

With multi-head pumps, parts of the individual pump heads can be confused.

- ➔ Replace the diaphragm and valve plates of the individual pump heads consecutively.



WARNING

Health hazard due to dangerous substances in the pump!

Depending on the substance transferred, caustic burns or poisoning are possible.

- ➔ Wear protective clothing if necessary, e.g. protective gloves.
- ➔ Clean pump with suitable measures.

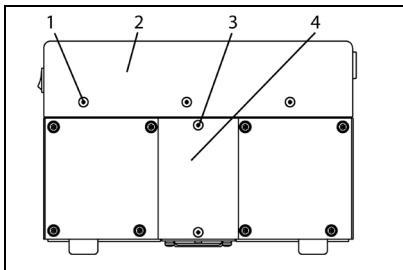

Fig. 15: Covering shroud and covers (N 940.5 APE-W)

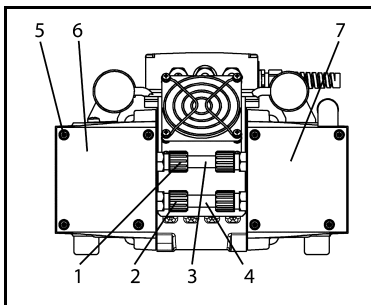

Fig. 16: Removing pump head (example N 940.5 APE)

a) Preparatory Steps

(only for pump type N 940.5 APE-W)

1. Loosen the covering shroud's (2, Fig. 15) three screws (1) on each of the pump's front and rear sides.
2. Carefully lift up the covering shroud; then open the mains-switch cable's plug connection and remove the covering shroud.
3. At the front and rear sides of the pump, loosen the two screws (3) for each of the two covers (4) and remove the covers.

b) Replacing valve plates and the diaphragm at the first pump head

Removing pump head

1. At the pneumatic connections (3, Fig. 16) and (4) between the first and second pump head: Use pliers to loosen union nuts (1) and (2) by turning them counterclockwise.
2. At the first pump head (6, Fig. 16) mark the position of head plate (2, Fig. 17), intermediate plate (6) and adapter (9) relative to each other by a drawing line with a felt-tip pen. This helps to ensure proper assembly.

i

N 940.5 APE-W:

If the ventilator obstructs when opening the pneumatic connection: On the underside of the pump, loosen the ventilator's three attachment screws and remove the ventilator.

3. At the first pump head unscrew the four screws (1, Fig. 17) and remove the head plate (2). Intermediate plate (6) is visible.
4. Take off intermediate plate (6) from adapter (9).

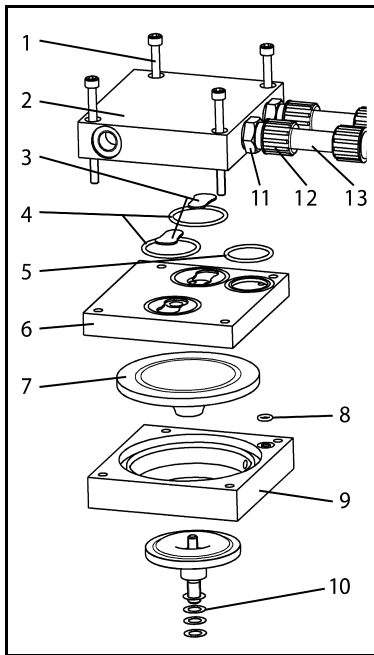

Fig. 17: Replacing diaphragm and valve plates (1. and 2. pump head)

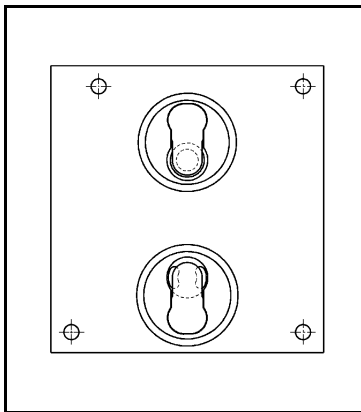

Fig. 18: Position of valve plates

Replacing valve plates

1. Remove the two valve plates (3), the two O-rings (4) and the O-ring (5) from the intermediate plate (6).
- i** The O-rings may also stick to the underside of the head plate (2).
2. Check the valve seats, intermediate plate (6) and head plate (2) for soiling and damage. Clean the parts if necessary.
 3. Contact KNF in case of roughness, scratches and corrosion. Order and replace damaged parts.
 4. Lay new valve plates (3) in the valve seats of the intermediate plate (6). See fig. 12 for position.
- i** The valve plates for the pressure and suction side are identical. The same applies to the upper and lower side of the valve plates.
5. Insert two new O-rings (4) and new O-ring (5) into the seat in the intermediate plate (6).

Replacing diaphragm

1. Use a small screwdriver to carefully lift up the outside edge of the diaphragm (7) from the adapter (9) and grasp the diaphragm.
2. Grasp the diaphragm (7) by the opposing side edges and unscrew it in the counter-clockwise direction.
3. Remove O-ring (8) from adapter (9).
4. Check all parts for soiling and clean if necessary.
5. Lay new O-ring (8) in the seat of adapter (9).
6. Screw the new diaphragm into vacuum diaphragm (10) by hand and tighten hand-tight.

Mounting pump head

1. Place the intermediate plate (6) with valve plates (3), O-rings (4) and O-ring (8) on the adapter (9) in accordance with the felt-tip pen marking.
2. Place the head plate (2) on the intermediate plate (6) in accordance with the felt-tip pen marking. In doing so, pull the pneumatic connections (13) onto the two screw fittings (11) in the head plate. Do not yet tighten the union nuts (12).
3. Make sure that the adapter (9), intermediate plate (6), and head plate are flush with each other.
4. Tighten the four screws (1) diagonally hand-tight.

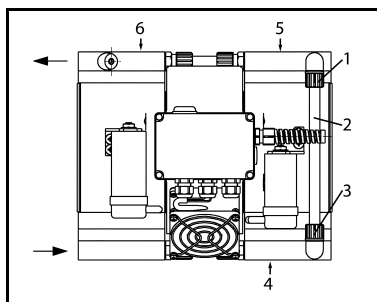

Fig. 19: Pneumatic connection between pump heads 2 and 3 (Example N 940.5 APE)

c) Replacing valve plates and the diaphragm at the second pump head

i Second pump head: See position (4) in Fig. 19.

Work steps as described under b) for the first pump head:

1. Removing pump head:

Step 1 is not applicable because the pneumatic connection is still open.

Additional step: At the pneumatic connection between pump heads 2 and 3 (2, Fig. 19) use pliers to turn union nuts (1) and (3) counterclockwise, thereby loosening them.

2. Replacing valve plates

3. Replacing diaphragm

4. Mounting pump head

Then use pliers to securely tighten (turn in clockwise direction) the two union nuts (12, Fig. 17) at the two pneumatic connections (13) between pump heads 1 and 2.

Pump N 940.5 APE-W:

If you removed the ventilator at the underside of the pump, replace it now.

d) Replacing valve plates and the diaphragm at the third pump head

Removing pump head

1. At the pneumatic connections (2, Fig. 19) between the second (4) and third (5) pump head: Use pliers to loosen union nuts (1) and (3) by turning them counterclockwise.

2. At the third pump head (5, Fig. 19) mark the position of head plate (2, Fig. 20), intermediate plate (5) and pump housing relative to each other by a drawing line with a felt-tip pen. This helps to ensure proper assembly.

i N 940.5 APE-W:
If the ventilator obstructs when opening the pneumatic connection: On the underside of the pump, loosen the ventilator's three attachment screws and remove the ventilator.

3. At the third pump head unscrew the four screws (1, Fig. 20) and remove the head plate (2). Intermediate plate (5) is visible.

4. Take off intermediate plate (5) from pump housing.

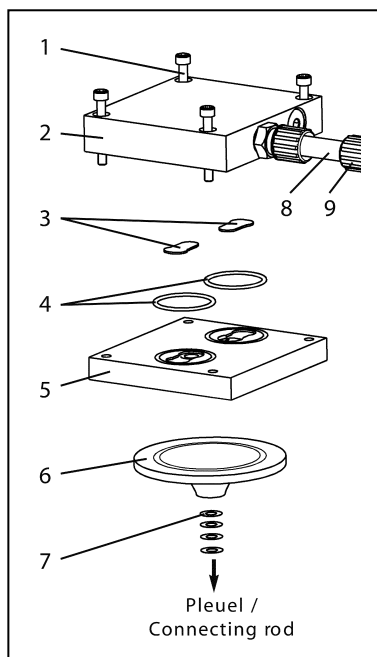

Fig. 20: Replacing diaphragm and valve plates (3. and 4. pump head)

Replacing valve plates

1. Remove the two valve plates (3, Fig. 20), the two O-rings (4) from the intermediate plate (5).

i The O-rings may also stick to the underside of the head plate (2).

2. Check valve seats and intermediate plate (5) for soiling and damage. Clean the parts if necessary.
3. Contact KNF in case of roughness, scratches and corrosion. Order and replace damaged parts.
4. Lay new valve plates (3) in the valve seats of the intermediate plate (5). See Fig. 18 for position.

i The valve plates for the pressure and suction side are identical. The same applies to the upper and lower side of the valve plates.

5. Lay the two new O-rings (4, Fig. 20) in the seats of intermediate plate (5).

Replacing diaphragm

1. Use a small screwdriver to carefully lift up the outside edge of the diaphragm (6) from the pump housing and grasp the diaphragm.

2. Grasp the diaphragm (6) by the opposing side edges and unscrew it in the counter-clockwise direction.

i Make sure the connecting rod between the diaphragm and the pump drive does not tilt away and that the diaphragm spacers (7) do not fall into the crankcase housing.

3. Check all parts for soiling and clean if necessary.
4. Screw the new diaphragm (6) into the connecting rod (connecting part between diaphragm and drive shaft) by hand and tighten hand-tight.

i Use the same number and arrangement of diaphragm spacers in order to ensure that the pump achieves its rated pneumatic performance.

Mounting pump head

1. Place the intermediate plate (5) with valve plates (3) and O-rings (4) on the pump housing in accordance with the felt-tip pen marking.
2. Place the head plate (2) on the intermediate plate (5) in accordance with the felt-tip pen marking. In doing so, pull the pneumatic connections (2, Fig. 19) onto the two screw fittings in the head plate of the second pump head (4) and the third pump head (5). Do not yet tighten the union nuts (1) and (3).
3. Make sure that the pump housing, intermediate plate (5, Fig. 20), and head plate (2) are flush with each other.
4. Tighten the four screws (1) diagonally hand-tight.

5. Use pliers to securely tighten (turn in clockwise direction) the two union nuts (**1**, Fig. 19) and (**3**) at the pneumatic connection between pump heads 2 and 3.

e) Replacing valve plates and the diaphragm at the fourth pump head

i Fourth pump head: See position (**6**) in Fig. 19.

Work steps as described under d) for the third pump head:

1. Removing pump head:
Step 1 is not applicable because the pneumatic connection is still open.
2. Replacing valve plates
3. Replacing diaphragm
4. Mounting pump head

Then use pliers to securely tighten (turn in clockwise direction) the union nuts (**9**, Fig. 20) at the two pneumatic connections (**8**) between pump heads 3 and 4.

Final steps

(only for pump type N 940.5 APE-W)

1. Connect the mains-switch cable's plug and re-install the covering shroud (**2**, Fig. 15).

i Make sure that no electrical cables are pinched.

2. Re-install the two cover plates (**4**, Fig. 15).

8.3.2. N 940.5 TTE

- Conditions
- Motor disconnected from mains and de-energized
 - Pump clean and free of dangerous substances

Spare parts

Spare part*	Position	Quantity
Diaphragm (with marking, see fig. 19)	(7) in Fig. 22	2
Diaphragm (without marking)	(6) in Fig. 26	2
Valve plate	(3) in Fig. 22 and Fig. 26	8
O-ring d 32 mm	(4) in Fig. 22 and Fig. 26	8
O-ring d 24 mm	(5) in Fig. 22	2
O-ring d 5.5 mm	(8) in Fig. 22	2

Tab. 18

* According to Spare parts list, chapter 10

Tools and material

Anz.	Tools/material
1	Allen key 4 mm
1	Small screwdriver
1	Pair of pliers
1	Felt-tip pen

Tab. 19

Information on procedure

- ➔ Always replace the valve plates and diaphragms together to maintain the pump performance.

With multi-head pumps, parts of the individual pump heads can be confused.

- ➔ Replace the diaphragm and valve plates of the individual pump heads consecutively.



WARNING

Health hazard due to dangerous substances in the pump!

Depending on the substance transferred, caustic burns or poisoning are possible.

- ➔ Wear protective clothing if necessary, e.g. protective gloves.
- ➔ Clean pump with suitable measures.

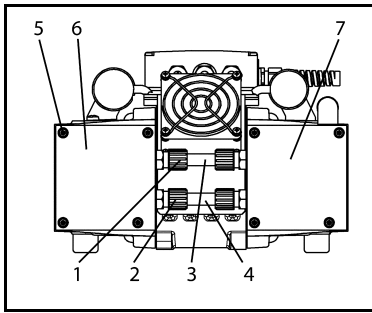

Fig. 21: Removing pump head

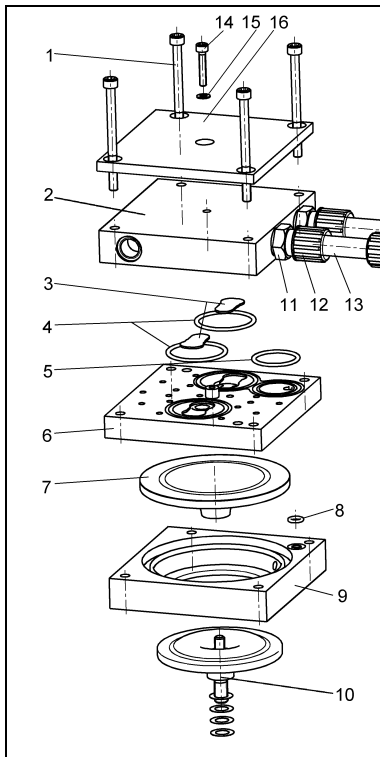

Fig. 22: Replacing diaphragm and valve plates (1. and 2. pump head)

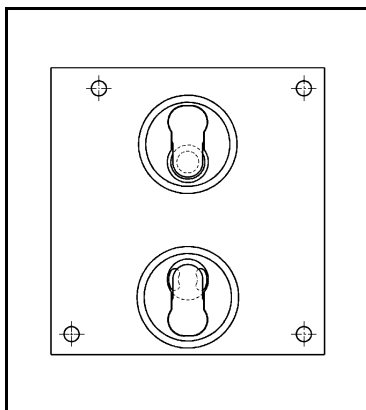

Fig. 23: Position of valve plates

a) Replacing valve plates and the diaphragm at the first pump head

Removing pump head

1. At the pneumatic connections (3, Fig. 21) and (4) between the first and second pump head: Use pliers to loosen union nuts (1) and (2) by turning them counterclockwise.
2. At the first pump head (6, Fig. 21) mark the position of top plate (16, Fig. 22), head plate (2), intermediate plate (6) and adapter (9) relative to each other by a drawing line with a felt-tip pen. This helps to ensure proper assembly.
3. At the first pump head unscrew the four screws (1, Fig. 22) and screw (14); remove the top plate (16) and head plate (2). Intermediate plate (6) is visible.
4. Take off intermediate plate (6) from adapter (9).

Replacing valve plates

1. Remove the two valve plates (3), the two O-rings (4) and the O-ring (5) from the intermediate plate (6).
- i** The O-rings may also stick to the underside of the head plate (2).
2. Check the valve seats, intermediate plate (6) and head plate (2) for soiling and damage. Clean the parts if necessary.
 3. Contact KNF in case of roughness, scratches and corrosion. Order and replace damaged parts.
 4. Lay new valve plates (3) in the valve seats of the intermediate plate (6). See fig. 17 for position.
- i** The valve plates for the pressure and suction side are identical. The same applies to the upper and lower side of the valve plates.
5. Insert two new O-rings (4) and new O-ring (5) into the seat in the intermediate plate (6).

Replacing diaphragm

1. Use a small screwdriver to carefully lift up the outside edge of the diaphragm (7) from the adapter (9) and grasp the diaphragm.
2. Grasp the diaphragm (7) by the opposing side edges and unscrew it in the counter-clockwise direction.
3. Remove O-ring (8) from adapter (9).
4. Check all parts for soiling and clean if necessary.
5. Lay new O-ring (8) in the seat of adapter (9).
6. Screw the new diaphragm with marking (see Fig. 24) (7) into vacuum diaphragm (10) by hand and tighten hand-tight.

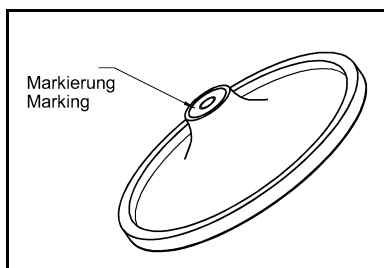

Fig. 24: Marking at diaphragm (7)

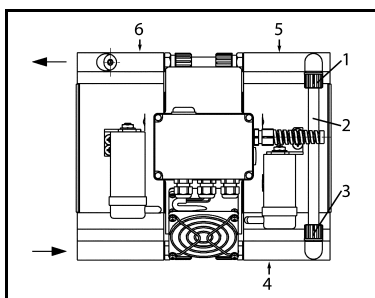

Fig. 25: Pneumatic connection between pump heads 2 and 3

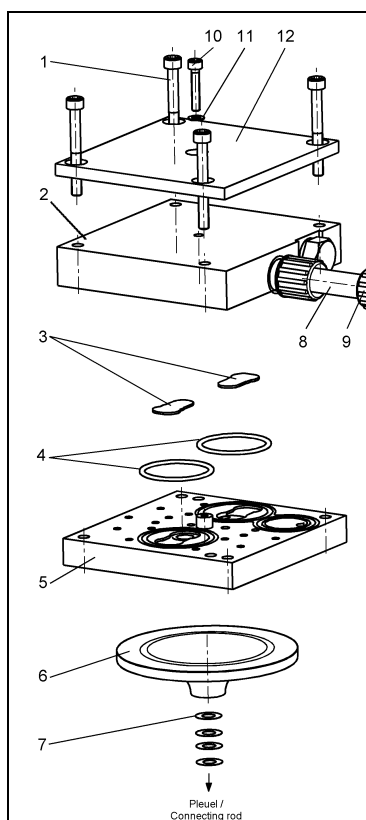

Fig. 26: Replacing diaphragm and valve plates (3. and 4. pump head)

Mounting pump head

1. Place the intermediate plate (6) with valve plates (3), O-rings (4) and O-ring (8) on the adapter (9) in accordance with the felt-tip pen marking.
2. Place the head plate (2) on the intermediate plate (6) in accordance with the felt-tip pen marking. In doing so, pull the pneumatic connections (13) onto the two screw fittings (11) in the head plate. Do not yet tighten the union nuts (12).
3. Place the top plate (16) on the head plate (2).
4. Make sure that the adapter (9), intermediate plate (6), head plate (2) and top plate (16) are flush with each other.
5. Tighten the four screws (1) diagonally hand-tight.
6. Tighten the screw (14) hand-tight.

b) Replacing valve plates and the diaphragm at the second pump head

i Second pump head: See position (4) in Fig. 25.

Work steps as described under a) for the first pump head:

1. Removing pump head:

Step 1 is not applicable because the pneumatic connection is still open.

Additional step: At the pneumatic connection between pump heads 2 and 3 (2, Fig. 25) use pliers to turn union nuts (1) and (3) counterclockwise, thereby loosening them.

2. Replacing valve plates
3. Replacing diaphragm
4. Mounting pump head

Then use pliers to securely tighten (turn in clockwise direction) the two union nuts (12, Fig. 22) at the two pneumatic connections (13) between pump heads 1 and 2.

c) Replacing valve plates and the diaphragm at the third pump head

Removing pump head

1. At the pneumatic connections (2, Fig. 25) between the second (4) and third (5) pump head: Use pliers to loosen union nuts (1) and (3) by turning them counterclockwise.
2. At the third pump head (5, Fig. 25) mark the position of top plate (12, Fig. 26), head plate (2), intermediate plate (5) and pump housing relative to each other by a drawing line with a felt-tip pen. This helps to ensure proper assembly.
3. At the third pump head unscrew the four screws (1, Fig. 26) and screw (10); remove the top plate (12) head plate (2). Intermediate plate (5) is visible.
4. Take off intermediate plate (5) from pump housing.

Replacing valve plates

1. Remove the two valve plates (3), the two O-rings (4) from the intermediate plate (5).

i The O-rings may also stick to the underside of the head plate (2).

2. Check valve seats and intermediate plate (5) for soiling and damage. Clean the parts if necessary.

3. Contact KNF in case of roughness, scratches and corrosion. Order and replace damaged parts.

4. Lay new valve plates (3) in the valve seats of the intermediate plate (5). See Fig. 23 for position.

i The valve plates for the pressure and suction side are identical. The same applies to the upper and lower side of the valve plates.

5. Lay the two new O-rings (4, Fig. 26) in the seats of intermediate plate (5).

Replacing diaphragm

1. Use a small screwdriver to carefully lift up the outside edge of the diaphragm (6) from the pump housing and grasp the diaphragm.

2. Grasp the diaphragm (6) by the opposing side edges and unscrew it in the counter-clockwise direction.

i Make sure the connecting rod between the diaphragm and the pump drive does not tilt away and that the diaphragm spacers (7) do not fall into the crankcase housing.

3. Check all parts for soiling and clean if necessary.

4. Screw the new diaphragm (without marking) (6) into the connecting rod (connecting part between diaphragm and drive shaft) by hand and tighten hand-tight.

i Use the same number and arrangement of diaphragm spacers in order to ensure that the pump achieves its rated pneumatic performance.

Mounting pump head

1. Place the intermediate plate (5) with valve plates (3) and O-rings (4) on the pump housing in accordance with the felt-tip pen marking.
2. Place the head plate (2) on the intermediate plate (5) in accordance with the felt-tip pen marking. In doing so, pull the pneumatic connections (2, Fig. 25) onto the two screw fittings in the head plate of the second pump head (4) and the third pump head (5). Do not yet tighten the union nuts (1) and (3).
3. Place the top plate (12, Fig. 26) on the head plate (2).
4. Make sure that the pump housing, intermediate plate (5), head plate (2) and top plate (12) are flush with each other.
5. Tighten the four screws (1) diagonally hand-tight.
6. Tighten the screw (10) hand-tight.
7. Use pliers to securely tighten (turn in clockwise direction) the two union nuts (1, Fig. 25) and (3) at the pneumatic connection between pump heads 2 and 3.

d) Replacing valve plates and the diaphragm at the fourth pump head

i Fourth pump head: See position (6) in Fig. 25.

Work steps as described under c) for the third pump head:

1. Removing pump head:
Step 1 is not applicable because the pneumatic connection is still open.
2. Replacing valve plates
3. Replacing diaphragm
4. Mounting pump head

Then use pliers to securely tighten (turn in clockwise direction) the union nuts (9, Fig. 26) at the two pneumatic connections (8) between pump heads 3 and 4.

9. Troubleshooting



Extreme danger from electrical shock!

→ Disconnect the pump power supply before working on the pump.

DANGER

→ Make sure the pump is de-energized and secure.

→ Check the pump (see Tab. 20 and Tab. 21).

Pump does not transfer	
Cause	Fault remedy
Pump is not connected with the power source.	→ Connect pump with the power source.
No voltage in the power source	→ Check room fuse and switch on if necessary.
Fuse(s) in the pump defective. (only for the pumps N 940.5 APE and N 940.5 TTE)	<ul style="list-style-type: none"> → Remove pump's mains plug from the socket. → Release the terminal-box cover on the top side of the pump. → Select suitable fuse (see section 4) and replace fuse(s). → Install the terminal-box cover.
Thermal-switch or electronics of pump has/have operated following to overheating.	<ul style="list-style-type: none"> → Remove pump's mains plug from the socket. → Allow pump to cool. → Trace cause of over-heating and eliminate it.
Connections or lines blocked.	<ul style="list-style-type: none"> → Check connections and lines. → Remove blockage.
External valve is closed or filter is clogged.	→ Check external valves and filters.
Condensate has collected in pump head.	<ul style="list-style-type: none"> → Detach the condensate source from the pump. → Flush the pump with air (if necessary for safety reasons: with an inert gas) for several minutes under atmospheric conditions.
Diaphragms or valve plates are worn.	→ Replace diaphragms and valve plates (see section 8.3).

Tab. 20

Flow rate, pressure or vacuum too low	
The pump does not achieve the output specified in the Technical data or the data sheet.	
Cause	Fault remedy
Condensate has collected in pump head.	<ul style="list-style-type: none"> ➔ Detach the condensate source from the pump. ➔ Flush the pump with air (if necessary for safety reasons: with an inert gas) for several minutes under atmospheric conditions.
There is gauge pressure on pressure side and at the same time vacuum or a pressure above atmospheric pressure on suction side.	<ul style="list-style-type: none"> ➔ Change the pressure conditions.
Pneumatic lines or connection parts have an insufficient cross section.	<ul style="list-style-type: none"> ➔ Disconnect pump from system to determine output values. ➔ Eliminate throttling (e.g. valve) if necessary. ➔ Use lines or connection parts with larger cross section if necessary.
Leaks occur on connections, lines or pump head.	<ul style="list-style-type: none"> ➔ Eliminate leaks.
Connections or lines completely or partially jammed.	<ul style="list-style-type: none"> ➔ Check connections and lines. ➔ Remove the jamming parts and particles.
Head parts are soiled.	<ul style="list-style-type: none"> ➔ Clean head components.
Diaphragms or valve plates are worn.	<ul style="list-style-type: none"> ➔ Replace diaphragms and valve plates (see section 8.3).

Tab. 21

Fault cannot be rectified

If you are unable to determine any of the specified causes, send the pump to KNF Customer Service (see last page for the address).

1. Flush the pump under atmospheric conditions some minutes with air (if necessary for safety reasons: with an inert gas) to free the pump head of dangerous or aggressive gases (see chapter 8.2.1).
2. Clean the pump (see chapter 8.2.2).
3. Send the pump, together with completed Health and Safety Clearance and Decontamination Form, to KNF stating the nature of the transferred medium.

10. Spare Parts and Accessories

Spare parts

N 940.5 APE

N 940.5 APE-W

Spare part	Position	Order No.
Diaphragm	(7) in Fig. 17 (6) in Fig. 20	112089
Valve plate	(3) in Fig. 17 and Fig. 20	112130
O-ring d 32 mm	(4) in Fig. 17 and Fig. 20	112122
O-ring d 26 mm	(5) in Fig. 17	112121
O-ring d 5.5 mm	(8) in Fig. 17	112123

Tab. 22

N 940.5 TTE

Spare part	Position	Order No.
Diaphragm (with marking)	(7) in Fig. 22	116787
Diaphragm (without marking)	(6) in Fig. 26	117534
Valve plate	(3) in Fig. 22 and Fig. 26	118007
O-ring d 32 mm	(4) in Fig. 22 and Fig. 26	116407
O-ring d 24 mm	(5) in Fig. 22	002454
O-ring d 5.5 mm	(8) in Fig. 22	059725

Tab. 23

Accessories

N 940.5 APE-W

Accessories	Order No.
Silencer (G 3/8)	045993
Adapter for silencer (from G 3/8 to G 1/4)	014757
Small flange stainless steel (G 1/4, DN 16)	048116
Hose connector, brass (G 1/4, for tube ID 13)*	049880
Hose connector, PP (G 1/4, for tube ID 10)	045293
Sealing for hose connector, brass	029112
Completely connectorized control cable (analog or digital controlling)	On request
PWM analog voltage converter Function: Smoothing of the speed output signal into an analog voltage output and simultaneous transformation of 5V to ≤ 5V	On request
External potentiometer for setting of the speed	On request
RS232 Level-Translator with SUB-D9 plug	On request
RS232 Level-Translator with Micro-USB plug	On request

Tab. 24

* Needed for assembly:

Sealing for hose connector (brass), Order No. 029112

N 940.5 APE

Accessories	Order No.
Silencer (G 3/8)	045993
Adapter for silencer (from G 3/8 to G 1/4)	014757
Small flange stainless steel (G 1/4, DN 16)	048116
Hose connector, brass (G 1/4, for tube ID 13)*	049880
Hose connector, PP (G 1/4, for tube ID 10)	045293
Sealing for hose connector, brass	029112

Tab. 25

* Needed for assembly:

Sealing for hose connector (brass), Order No. 029112

N 940.5 TTE

Accessories	Order No.
Small flange stainless steel (G 1/4, DN 16)	048116
Hose connector, PP (G 1/4, for tube ID 10)	045293
Silencer (G 3/8)	045993
Adapter for silencer (G 3/8 to G 1/4)	014757

Tab. 26

11. Returns

Preparing for return

1. Flush the pump with air for a few minutes (if necessary for safety reasons: with inert gas) at atmospheric pressure to free the pump head of dangerous or aggressive gases (see Chapter 8.2.1).

i Please contact your KNF sales partner if the pump cannot be flushed due to damage.

2. Remove the pump.
3. Clean up the pump (see chapter 8.2.2).
4. Send the pump together with the completed Health and Safety Clearance and Decontamination Form to KNF, stating the nature of the transferred medium.
5. Pack the device securely to prevent further damage to the product. If necessary, request original packaging for a fee.

Returns

KNF shall undertake to repair the pump only under the condition that the customer presents a certificate regarding the medium that is pumped and the cleaning of the pump. In this case too, old devices can be returned. Please follow the instructions at knf.com/repairs here.

Contact your KNF sales partner directly if you require additional support for your return service.

KNF worldwide

Find your local KNF partner on www.knf.com