

OEM

N96_DC-B-M
TRANSLATION OF ORIGINAL OPERATING AND
INSTALLATION INSTRUCTION
ENGLISH

DIAPHRAGM PUMP

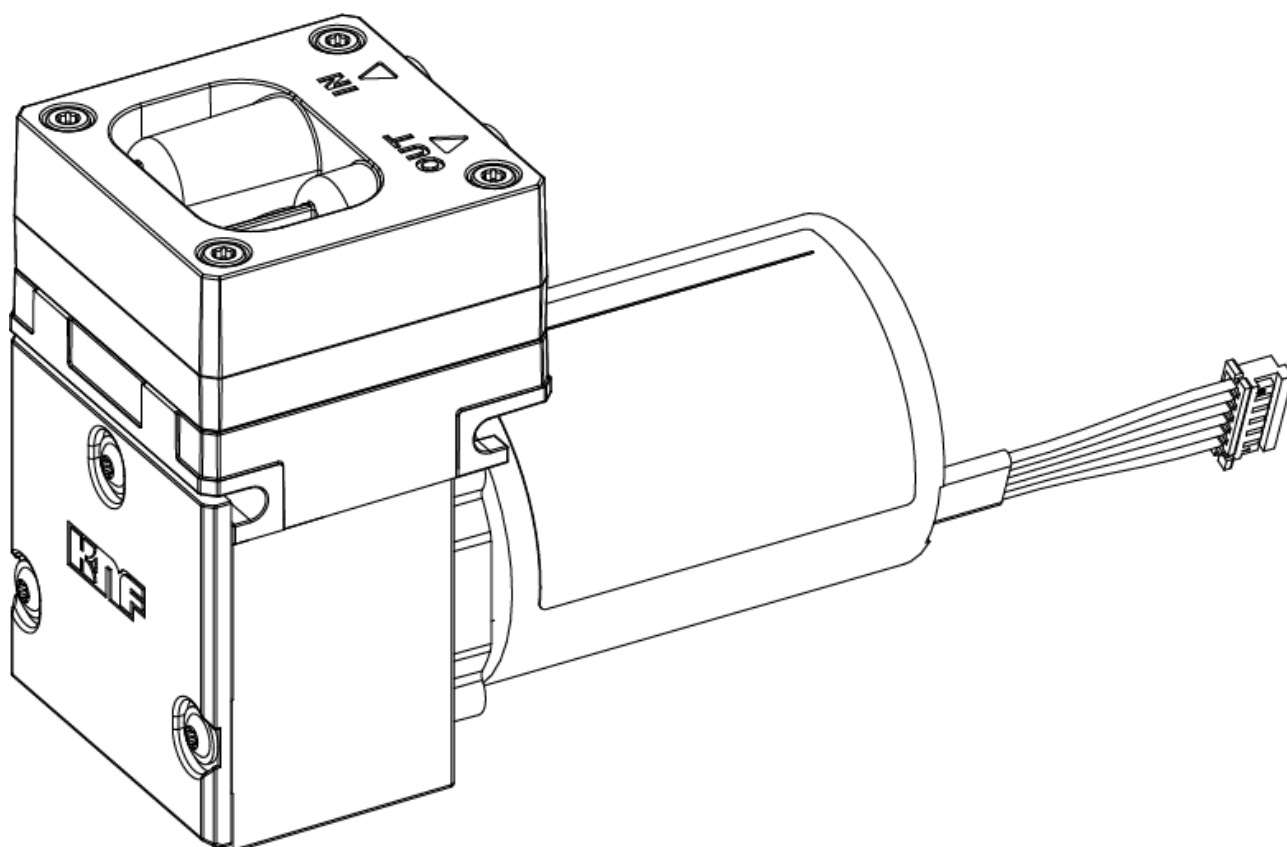

Notice!

Before operating the pump and accessories, read and observe the operating and installation instructions as well as the safety information!

KNF Neuberger GmbH
Alter Weg 3
79112 Freiburg
Germany
Tel. +49 (0)7664/5909-0
Fax. +49 (0)7664/5909-99

www.knf.com

Index

1	About this document	3
1.1	Using the operating and installation instructions.....	3
1.2	Exclusion of liability.....	3
1.3	Symbols and markings.....	3
1.4	List of abbreviations	5
2	Safety	6
2.1	Personnel and target group	6
2.2	Responsibility of the operator	6
2.3	Working in a safety conscious manner	7
2.4	Operating conditions	7
2.5	Media	7
2.6	Use.....	8
2.7	Directives and standards	9
2.8	Customer service and repair.....	9
2.9	Disposal	9
3	Technical data.....	10
	Technical data.....	10
4	Product description	13
5	Transport.....	15
	General	15
6	Installation and connection.....	16
6.1	Installing the pump.....	16
6.2	Aligning gas connections	18
6.3	Electrical connection	19
6.4	Pneumatic connection.....	21
7	Operation	22
7.1	General	22
7.2	Information on switching the pump on and off	24
7.3	Control functions DC-B-M.....	24
8	Servicing	25
8.1	Servicing schedule.....	25
8.2	Cleaning.....	26
8.3	Replacing diaphragm and valve plates	27
9	Spare parts and accessories.....	30
9.1	Spare parts	30
9.2	Accessories.....	30
10	Troubleshooting	31
11	Returns.....	33

1 About this document

1.1 Using the operating and installation instructions

The operating and installation instructions are part of the pump.

- In the event of uncertainties with regard to the content of the operating and installation instructions, please contact the manufacturer (contact data: see www.knf.com). Please have the type and serial number of the pump ready.
- Read the operating and installation instructions before you commission the pump.
- Give the operating and installation instructions only completely and unchanged to the next owner.
- Keep the operating and installation instructions within reach at all times.

Project pumps For customer-specific project pumps (pump models that begin with "PJ" or "PM"), there may be deviations from these operating and installation instructions.

- For project pumps, also observe the agreed specifications.

Optional contents Project-specific options may be included in the operating and assembly instructions. These are marked with "Optional". It is also possible that project-specific deviations are not included in the operating and assembly instructions.

1.2 Exclusion of liability

The manufacturer assumes no liability for damages and malfunctions resulting from failure to observe the operating and installation instructions.

The manufacturer assumes no liability for damages and malfunctions resulting from changes or modifications to the device and improper handling.

The manufacturer assumes no liability for damages and malfunctions resulting from impermissible spare parts and accessories.

1.3 Symbols and markings

Warning notice



A notice that warns you of danger is located here.

Possible consequences of a failure to observe the warning notice are specified here. The signal word, e.g., Warning, indicates the danger level.

- Measures for avoiding the danger and its consequences are specified here.
-

Danger levels

Signal word	Meaning	Consequences if not observed
DANGER	warns of immediate danger	Death or serious injury or serious damage will result.
WARNING	warns of possible danger	Death, serious injury or serious damage is possible.
CAUTION	warns of a possibly dangerous situation	Minor injury or damage is possible.
NOTICE	Warns of possible damage	Damage is possible.

Tab.1 Danger levels







Other notices and symbols

→ An activity to be carried out is specified here (a step).

1. The first step of an activity to be carried out is specified here. Other sequentially numbered steps follow.

i This symbol indicates important information.

Explanation of pictograms

Pictogram	Meaning
	General warning symbol
	Warning of hot surface
	Warning of electrical voltage
	Warning of poisonous substances
	Warning of hand injuries through crushing
	Observe the operating instructions
	General mandatory sign

Tab.2 Explanation of pictograms

1.4 List of abbreviations

Abbreviation	Term
PTFE	Polytetrafluoroethylene
FFKM	Perfluoro rubber
PVDF	Polyvinylidene fluoride
PP	Polypropylene
FKM	Fluororubber
FEP	Fluoroethylene propylene
ETFE	Ethylene tetrafluoroethylene copolymer
TFM	Modified PTFE
Tab.	Table
Fig.	Figure
a/o	And/or
e.g.	For example
Perm.	Permissible
et al.	And the like
opt.	If necessary
Max.	Maximum
Min.	Minimum
PWM	Pulse Width Modulation
CW	Clockwise
CCW	Counter-Clockwise
TTL	Transistor-Transistor Logic
DC	Direct Current
GND	Ground
KF	Small flange

2 Safety

i Observe the safety notices in Chapters 6 *Installation and connection* and 7 *Operation*.

2.1 Personnel and target group

Personnel Make sure that only specially trained and instructed personnel work on the pumps. This applies, in particular, to mounting, connection and servicing work.

Make sure that the personnel have read and understood the operating instructions, particularly the chapter on safety.

Target group	Target group	Definition
	User	Employee
	Specialized personnel	Specialized personnel are personnel who - have relevant professional training in the field covered in the particular section of text; - have current knowledge of the field covered in the particular section of text.

Tab.3 Target group

Who-does-what matrix	Lifecycle phase	User	Specialized personnel
	Transport		X
	Mounting		X
	Connection		X
	Commissioning	X	X
	Operation	X	X
	Servicing		X
	Troubleshooting		X
	Disposal		X

Tab.4 Who-does-what matrix

2.2 Responsibility of the operator

The pumps are produced in accordance with the generally recognized rules of engineering, as well as the occupational health, safety and accident prevention regulations. Nevertheless, dangers can arise during their use that lead to injuries to the user or third parties or to damage to the pump or other property.

Only use the pumps in perfect technical condition, for their intended use, safely and with an awareness of the dangers and in observation of the operating and installation instructions.

The components that are to be connected to the pumps must be designed according to the pneumatic data of the pumps.

When connecting the pumps to the electrical power, observe the corresponding safety rules.

Make sure that no hazardous situation, physical harm or impairment of the pump can occur.

Operating parameters Only operate and install the pump under the operating parameters and operating conditions described in Chapters 2.4 *Operating conditions* and 3 *Technical data*.

2.3 Working in a safety conscious manner

Observe the regulations on accident prevention and safety during all work on the pumps and during operation.

Avoid contact with the pump heads and housing parts because the pump heats up during operation.

When working on the pump, make sure that the pump is disconnected from mains and without power.

When connecting the pump to the electrical mains, observe the corresponding safety rules.

Ensure that no hazards arise from gas flowing when gas connections are open, from the effects of noise or from hot, corrosive, dangerous and environmentally hazardous gases.

Make sure that an EMC-compliant installation of the pump is ensured at all times to prevent the occurrence of dangerous situations.

2.4 Operating conditions

Only use the pump in perfect technical condition, for its intended purpose, safely and with an awareness of the dangers and in observation of the operating instructions.

Only install and operate the pumps in accordance with the operating parameters and conditions described in Chapter 3 *Technical data*.

Only pumps that are fully assembled and in the condition as delivered may be operated.

Make sure that the installation location is dry and that the pump is protected from rain, splash water, gushing water, dripping water and other contamination.

Check the tightness of the connections between the pipes of the application and the pump (or the connection of the pump) at regular intervals. Leaky connections carry the risk of releasing dangerous gases and vapors from the pump system.

2.5 Media

Requirements of pumped media	<p>Before transferring a medium, check whether the medium can be transferred without risk in the specific application.</p> <p>Take note of any change in the state of matter (condensation, crystallization).</p> <p>Before using a medium, check the compatibility of the media-contacting components (see 3 <i>Technical data</i>) with the medium.</p> <p>Risk of dangerous gas mixtures during pump operation if diaphragm breaks: Depending on the medium being transferred, breakage of the diaphragm can result in a dangerous mixture if the medium mixes with the air in the compressor housing or the surroundings.</p> <p>Only transfer gases that remain stable under the pressures and temperatures that arise in the pump.</p>
Handling of hazardous media	<p>Upon breakage of the diaphragm and/or leaks, the transferred medium mixes with the air in the surroundings and/or in the pump housing.</p> <p>Make sure that a dangerous situation cannot arise as a result.</p> <p>When pumping hazardous media, observe the safety regulations for the handling of said media.</p>
Handling of combustible media	<p>Note that the pump is not designed to be explosion-proof.</p> <p>Make certain that the temperature of the medium is always sufficiently below the ignition temperature of the medium so as to prevent ignition or explosion. This also applies for abnormal operating situations.</p>

Note that the temperature of the medium increases when the pump compresses the medium.

Therefore, make certain that the temperature of the medium also remains sufficiently below the ignition temperature of the medium even when it is compressed to the maximum permissible operating pressure of the pump. The maximum permissible operating pressure of the pump is stated in Chapter 3 *Technical data*.

Make certain that the permissible ambient temperature (see 3 *Technical data*) is not exceeded.

Where applicable, also take into account external energy sources (such as radiated heat sources) that could additionally heat the medium.

In case of doubt, contact KNF Customer Service.

2.6 Use

2.6.1 Proper use

The pumps are intended exclusively for transferring gases and vapors.

The pumps are intended exclusively for operation in indoor areas and in non-explosive atmospheres.

2.6.2 Foreseeable misuse

The pumps must not be operated in explosive atmospheres.

The pumps are not suitable for transferring the following:

- Dusts
- Liquids
- Aerosols
- Biological and microbiological substances
- Fuels
- Explosives and flammable materials
- Fibers
- Oxidizing agents
- Foodstuffs.

As standard, the pumps must not be used for simultaneous generation of a vacuum and positive pressure.

This function can be made possible on a project basis following consultation with KNF Customer Service.

Do not apply positive pressure to the inlet of the pump.

This function can be made possible on a project basis following consultation with KNF Customer Service.

2.7 Directives and standards

EU/EC Directives	<p>Installation declaration – for partly completed machinery</p> <p>With respect to the Machinery Directive 2006/42/EC, the pumps are partly completed machinery and are, therefore, to be regarded as not ready for use. Partly completed machinery may not be commissioned until it has been determined that the machine into which the partly completed machinery is to be installed complies with the provisions of the Machinery Directive 2006/42/EC. The following fundamental requirements of Annex I of Directive 2006/42/EC (general principles) are applied and observed:</p> <ul style="list-style-type: none"> ▪ General principles no. 1 ▪ No. 1.1.2. / 1.1.3. / 1.3.1. / 1.3.3. / 1.3.4. / 1.4.1. / 1.5.8. / 1.5.9. / 1.7.4. / 1.7.4.1. / 1.7.4.3.
Standards	<p>The following standards apply:</p> <ul style="list-style-type: none"> ▪ EN IEC 61000-6-2 ▪ EN IEC 61000-6-3 ▪ EN IEC 63000 <p>The protective goals of the following directive(s) are achieved:</p> <ul style="list-style-type: none"> ▪ Directive 2011/65/EU on the restriction of the use of certain hazardous substances in electrical and electronic equipment (Annex II changed by delegated Directive (EU) 2015/863 of the Commission)

2.8 Customer service and repair

Customer service and repairs	<p>The pump is maintenance-free. However, KNF recommends periodic inspection of the pump for obvious changes in noise or vibration.</p> <p>Only have repairs to the pumps performed by qualified KNF personnel.</p> <p>Housings with electrically live components may only be opened by specialist personnel.</p> <p>Use only genuine spare parts from KNF when performing servicing work.</p>
------------------------------	--

2.9 Disposal

Environmental protection	<p>Store the pump and all accessories in accordance with the environmental provisions. Observe national and international regulations. This applies in particular to parts that are contaminated with toxic substances.</p> <p>If you no longer need your packaging materials (e.g. for return shipment or other transport of the device), dispose of them in an environmentally friendly manner.</p> <p>Old devices must not be disposed of with household waste. Proper disposal and recycling helps to protect natural resources and the environment. The end user is responsible for disposing of old devices according to national and international regulations. Alternatively, KNF products (old devices) may also be returned to KNF for a fee (see chapter 11 <i>Returns</i>).</p>
--------------------------	---

3 Technical data

Technical data

Pump materials

Assembly	Material KN	Material KT	Material AT	Material ST
Pump head	PPS	PPS	Aluminum	Stainless steel
Diaphragm	EPDM	PTFE-coated	PTFE-coated	PTFE-coated
Valves	FKM	FKM	FKM	FFKM

Tab.5 Pump materials KN/KT/AT/ST variant

Pneumatic values

N96KNDC-B-M

Parameter	Unit	Value
Max. permissible operating pressure	[bar rel*]	2.5
Ultimate vacuum	[mbar abs.]	<100
Flow rate at atm. pressure	[l/min]**	8.5 ± 10%

Tab.6 Pneumatic values

*Bar rel related to 1013 hPa

**Liters in the standard state based on ISO 8778 and ISO 21360-1/2 (1013 hPa, 20°C)

N96_TDC-B-M

Parameter	Unit	Value
Max. permissible operating pressure	[bar rel*]	2.5
Ultimate vacuum	[mbar abs.]	<130
Flow rate at atm. pressure	[l/min]**	7.0 ± 10%

Tab.7 Pneumatic values

*Bar rel related to 1013 hPa

**Liters in the standard state based on ISO 8778 and ISO 21360-1/2 (1013 hPa, 20°C)

Pneumatic connections

Pump type	Value
N96K_DC-B-M	G 1/8
N96K_DC-B-M-NPT	NPT 1/8
N96ATDC-B-M	G 1/8
N96STDC-B-M	G 1/8

Tab.8 Pneumatic connections

Electrical data

Parameter	Unit	Value KN version	Value KT/AT/ST version
Voltage	[V]	24	24
Frequency	[Hz]	-	-
Power P ₁	[W]	23	19
Max. permissible line voltage fluctuations	[%]	± 10	± 10
Motor protection class (DIN EN 60529 / IEC 60529)		IP20	IP20
Rated current consumption	[A]	1.05	0.9

Tab.9 Electrical data



The motor controller has a current limit of max. 2.5 A RMS. In the event of an error, the power of the motor is limited to prevent the current limit from being exceeded.

Weight

Pump type	Unit	Value
N96K_DC-B-M	[kg]	0.6
N96STDC-B-M	[kg]	0.9
N96ATDC-B-M	[kg]	0.65

Tab.10 Weight

Other parameters

Parameter	Unit	Value	
Permissible ambient temperature [°C]	[°C / °F]	+ 5 to see Fig. 1 0 if non-condensing (frost-free)	
Permissible media temperature [°C]	[°C / °F]	See Fig. 2	
Dimensions		See Fig. 5, Chapter 6.1 <i>Installing the pump</i>	
Highest permissible relative air humidity of the environment		80% for temperatures up to 31°C, decreasing linearly to 50% at 40°C.	
Maximum installation altitude [m above sea level]	[m / ft above sea level]	2000	
Gas tightness* of the pump head (leak rate)	[mbar l/s]	< 6 x 10 ⁻³	
Pump protection class (DIN EN 60529 / IEC 60529)		IP20	
Starts against		KN	KT / AT / ST
- Vacuum		100	130
- Pressure		2.5	2.5

Tab.11 Other parameters

*The gas tightness of the pump head is no longer ensured after the pump head is opened or after replacing diaphragms and valve plates. A leak test can be used to determine whether the original gas tightness has been re-established.

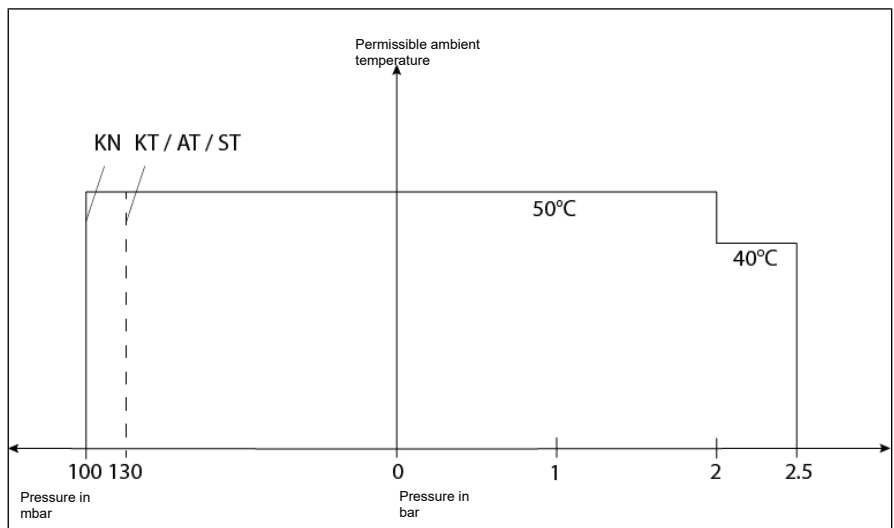

Fig.1 Permissible ambient temperature

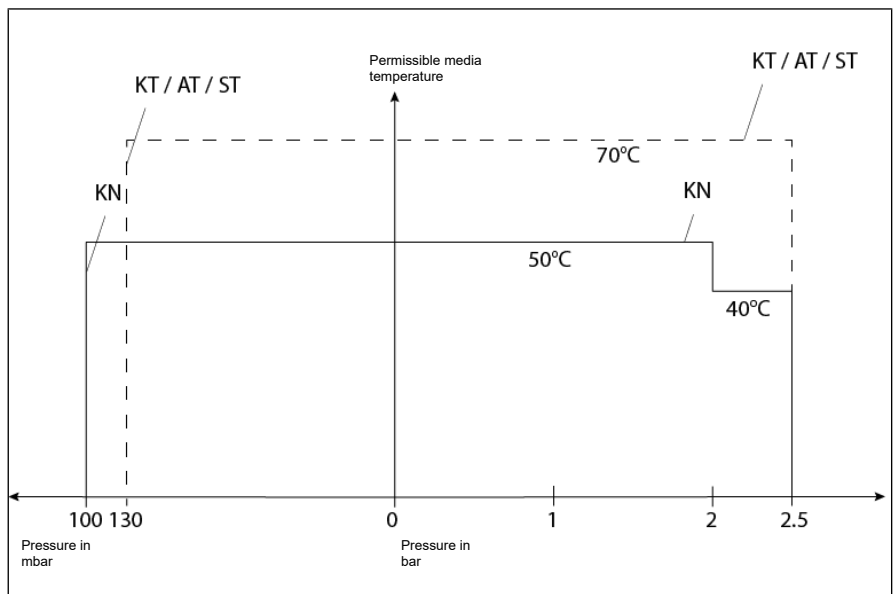

Fig.2 Permissible media temperature

4 Product description

Design

- 1 Pneumatic pump inlet
- 2 Pneumatic pump outlet
- 3 Motor
- 4 Electrical connection

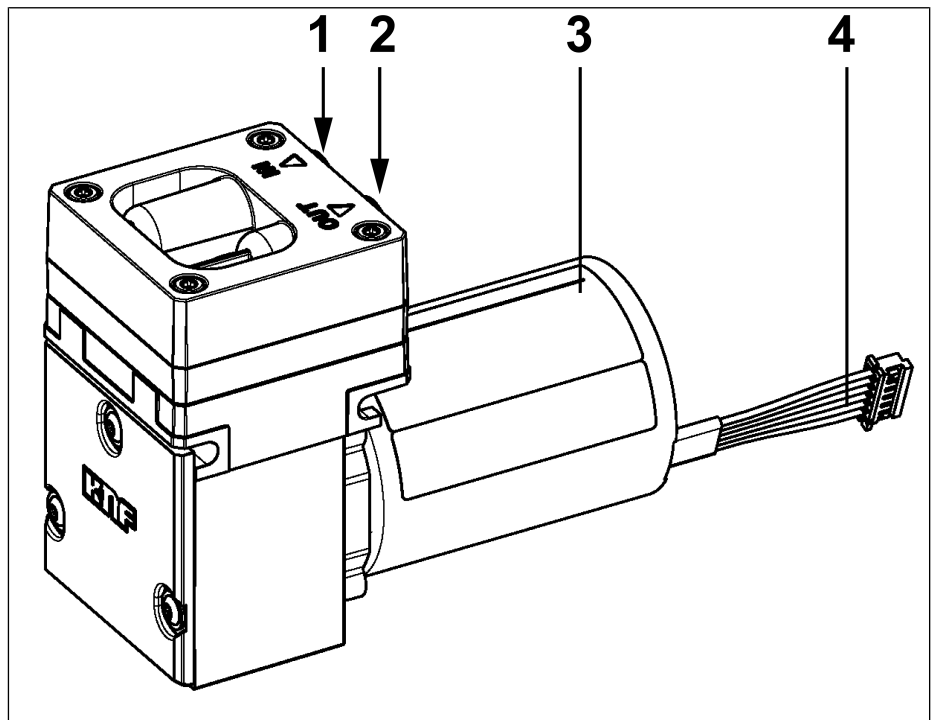

Fig.3 Design N96

Function of a diaphragm pump

- 1 Outlet valve
- 2 Inlet valve
- 3 Transfer chamber
- 4 Diaphragm
- 5 Eccentric
- 6 Connecting rod

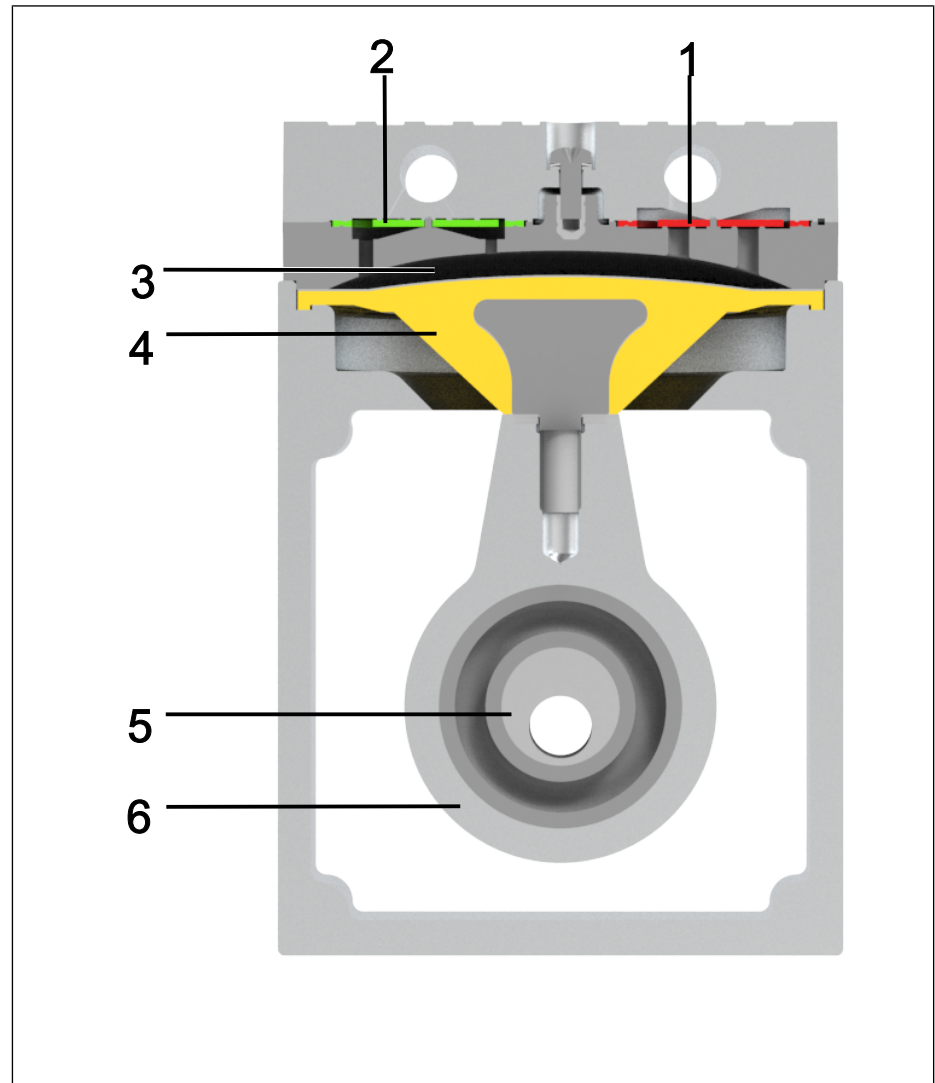

Fig.4 Function of a diaphragm pump

Diaphragm pumps transfer, compress (depending on the version) and evacuate gases and vapors.

The elastic diaphragm (4) is moved up and down by the eccentric (5) and the connecting rod (6). In the downwards stroke, it aspirates the gas to be transferred via the inlet valve (2). In the upwards stroke, the diaphragm presses the medium out of the pump head via the outlet valve (1). The transfer chamber (3) is separated from the pump drive by the diaphragm.

5 Transport

General



Personal injury and/or property damage due to incorrect or improper transport of the pump

In the event of incorrect or improper transport, the pump can fall down, be damaged or injure persons.

- Use suitable auxiliary means if necessary (carrying strap, lifting gear, etc.).
- Where appropriate, wear suitable personal protective equipment (e.g., safety shoes, safety gloves).



Risk of injury from sharp edges on the packaging

There is a risk of injury from cutting on the sharp edges when grabbing corners or when opening the packaging.

- Where appropriate, wear suitable personal protective equipment (e.g., safety shoes, safety gloves).

- Transport the pump in the original packaging to the installation location.
- Keep the original packaging of the pump (e.g. for later storage).
- Inspect the pump for transport damage after receiving it.
- Document any transport damage that has occurred.
- Remove any transport safeguards on the pump prior to commissioning.

Parameter

Parameter	Value
Storage temperature [°C]	+ 5 to + 40
Transport temperature [°C]	- 10 to + 60
Permissible humidity (non-condensing) [%]	30 to 85

Tab.12 Transport parameters and storage parameters



Prior to commissioning, make sure that the pump has reached the ambient temperature (3 *Technical data*).

6 Installation and connection

Only install the pumps in accordance with the operating parameters and conditions described in Chapter 3 *Technical data*.

→ Observe the safety instructions (see Chapter 2 *Safety*).



Risk of dangerous gas mixtures during pump operation

Depending on the medium being transferred, breakage of the media-contacting components can result in a dangerous mixture if the medium mixes with the air in the compressor housing or the surroundings.

→ Before using a medium, check the compatibility of the media-contacting components (see 3 *Technical data*) with the medium.

6.1 Installing the pump

→ Store the pump at the installation site to allow it to adapt to the ambient temperature before installation (condensation must not be allowed to form).



Risk of injury from freely rotating shaft end

Touching the pump at the end of the shaft may result in injury through burning and crushing.

→ Take protective measures to safeguard against touching moving and hot parts.

→ Wear appropriate personal protective equipment if necessary.



Risk of injury from sharp edges on motor

There is a risk of injury from cutting on the sharp edges when grabbing the pump on the motor.

→ Where appropriate, wear suitable personal protective equipment (e.g., safety shoes, safety gloves).

Mounting dimensions → For mounting dimensions, see the following illustrations:

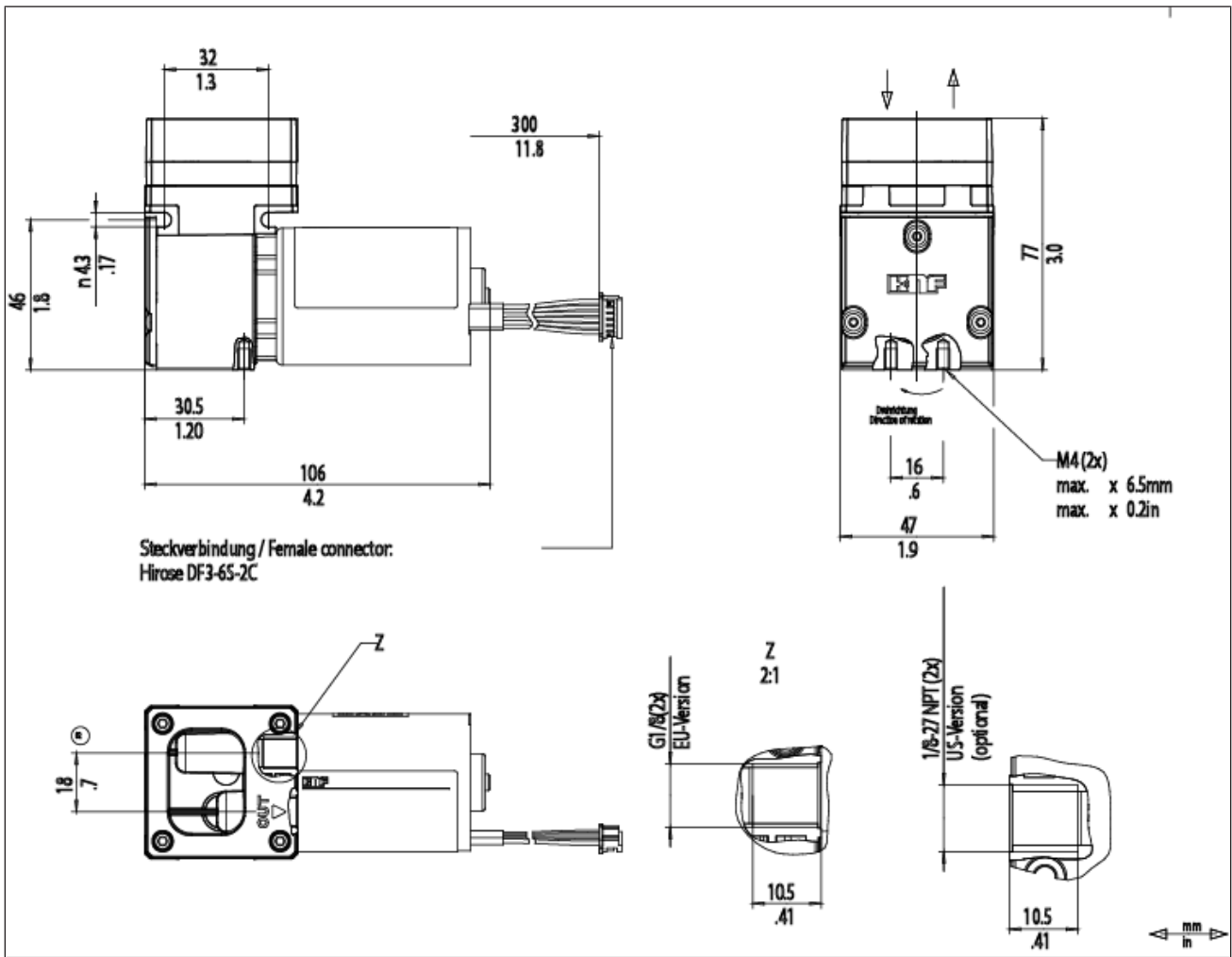

Fig.5 Mounting dimensions of pump series N96DC-B-M

Cooling air supply



Danger of burning on hot surfaces

Hot surfaces could occur if the pump overheats.

→ When installing the pump, make sure that sufficient cooling air infeed and discharge is ensured.

Proximity to hot pump parts

→ During installation, make sure that no combustible or thermally deformable objects are positioned in proximity to hot pump parts (head, motor).

Installation location

→ Make sure that the installation location is dry and that the pump is protected from rain, spray water, splash water, dripping water and other contaminants.

→ Make sure the installation location allows access for servicing.

i The IP protection class of the pump motor is specified on the type plate.

→ Install the pump at the highest point in the system to prevent condensate from collecting in the pump head.

→ Protect the pump from dust.

→ Protect the pump from vibration and impact.

- Installation position → The pump can be operated in any installation position. Use metal screws to fasten the pump at the indicated attachment points. Observe the specifications of the selected fasteners.
- Protection against foreign objects → Protect the pump against contact and the ingress of foreign bodies.

6.2 Aligning gas connections

Tool	Quantity	Tool/material
	1	Torx TX10 screwdriver

Tab.13

i To keep the hose routing as compact as possible, the gas connections can be oriented according to the system conditions. For this purpose, the pump head can be rotated in increments of 90° and mounted.

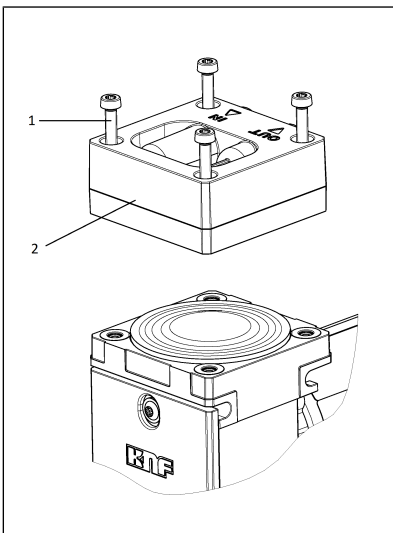

- Loosen the four head plate screws (1) and remove the pump head (2) from the compressor housing.
- Turn the pump head to the desired position.

i Direction of rotation according to the alignment of the gas connections, see following figure.

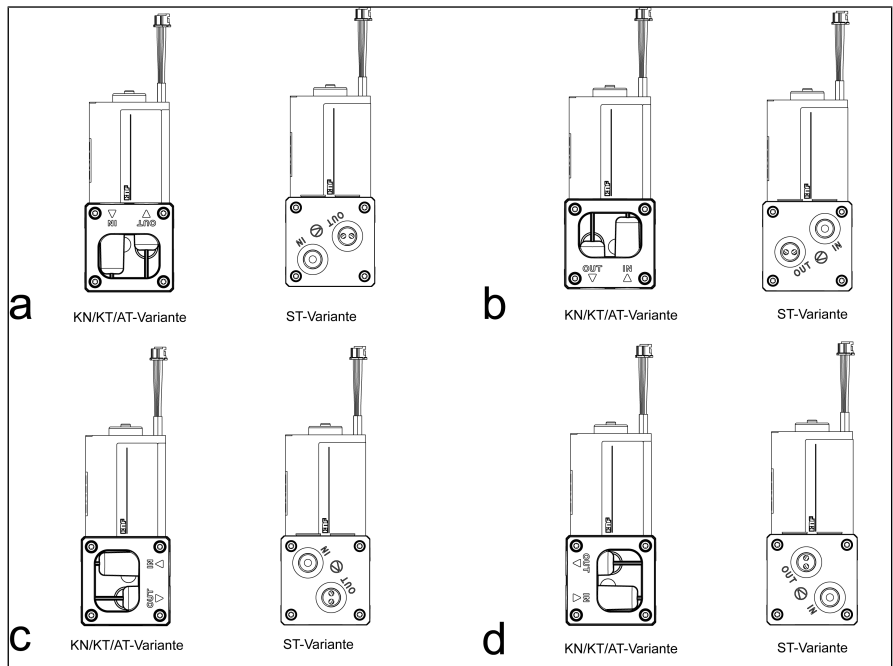

Fig.6 Aligning gas connections (pump head depicted as an example)

Fig.7 Aligning gas connections

A	Gas connections via motor: Direction of rotation: CW
B	Gas connections at front: Direction of rotation: CCW
C	Gas connections at right: Direction of rotation: CW
D	Gas connections at left: Direction of rotation: CCW

i Connection definition of the direction of rotation, see Connection diagram without speed setting, .

- Place the pump head (2) on the compressor housing.
- Tighten the four head plate screws (1) crosswise (tightening torque: ~190 Ncm / 16.8 in-lb).

6.3 Electrical connection



Danger to life from electric shock

- Only have the pump connected by an authorized specialist.
- Only have the pump connected if the power supply is disconnected.

- When connecting to a power source, observe the applicable standards, regulations, directives, and technical standards.
- Install a device for separating the pump motor from the electrical grid in the electrical installation (e.g. in accordance with EN 60335-1).
- The drives may only be operated in an SELV circuit.



NOTICE

The control lines of the BLDC motor are only protected to a voltage of up to 1.5 kV (acc. to HBM ESD rating).
If higher ESD requirements are needed, measures are to be provided by the owner himself.

- i** Refer to the type plate for the maximum current consumption of the pump.
- Install an Emergency Off device such that it is not possible for there to be an automatic restart or for hazardous situations to persons and property to occur.
- Install the pumps in such a way that it is not possible to touch electrically live parts (electrical connection).



NOTICE

The ground potential of the power supply, the interface(s) and the pump housing are to be at the same potential. Compensating currents via the drive controller are to be prevented as they may result in the destruction of the electronics. A sufficient potential equalization in accordance with EN 60479-1 is to be dimensioned.

Fastening the connection cables

- Fasten the connection cables so that
 - the cables do not come into contact with movable or hot parts.
 - the cables cannot be worn or damaged on sharp corners or edges
 - no tensile and pressure forces are exerted on the connection point of the cables (strain relief)

Connecting the pump

1. Confirm that the power supply meets the parameters listed on the pump type plate. Refer to the pump type plate for the rated current draw.

- i** The supply voltage may deviate by maximum +10% or –10% from the values on the type plate.



NOTICE

Take into account the direction of rotation according to the orientation of the gas connections (see Fig. 7, Connection diagram with speed setting and Connection diagram without speed setting).



NOTICE

Observe the correct sequence for connecting the drive controller

- Supply drive controller with an operating voltage.
- Apply control voltage.



NOTICE

Ensure the correct polarity. With brushless DC motors (indicated by a B at the end of the type designation), incorrect polarity will result in damage to the electronics.

Connection diagram for motor controller

Motor				
Plug connection		Hirose DF3-6S-2C (cable: AWG 26)		
PIN assignment				
Designation	Cable color	PIN	Function	Description
Supply voltage	Red	6	24V±10%	DC
GND potential	Black	1	0V	
Cycle speed setpoint	Blue	3	20 ± 5 kHz	TTL signal
Tachometer signal	Green	4	6 pulses/revolution	50% PWM TTL signal Max. 2mA
Motor ON/OFF	White	2	LOW signal = motor ON HIGH signal= motor OFF	TTL signal
Direction of rotation setting	Yellow	5	LOW signal = CCW HIGH signal= CW	TTL signal
Permissible PWM signal range*				
Cycle speed setpoint according to pump type (Max. speed at 0% PWM)			KN	KT/AT/ST
			30...0%	55...0%

Tab.14 Connection diagram for drive controller N96_DC-B-M
*see Chapter 7.3 Control functions DC-B-M



For expanded permissible cycle speed setpoints, please contact your KNF Customer Service (contact data: see www.knf.com).

6.4 Pneumatic connection



Personal injury or property damage through ejected plugs

If not removed, the plugs on the outlet of the pump can be ejected during operation by the resulting overpressure.

→ Remove the plugs during installation.

→ Wear appropriate personal protective equipment.

- | | |
|------------------------|--|
| Connected components | → Only connect components to the pump that are designed for the pneumatic data and thermal requirements of the pump. (see Chapter 3 <i>Technical data</i>). |
| Pressure relief device | → Protect the compressors by means of a pressure relief device between the pressure-side connections of the compressor and the first shut-off valve. |
| Pump discharge | → Discharge the possibly hot pump discharge at the pneumatic outlet of the pump safely (with regard to medium and noise). |
| Decoupling | → KNF recommends mechanically decoupling the pump from the pipe system, e.g., through the use of flexible hoses or pipes. In this way it is possible to prevent the transfer of possible pump vibrations and noises to the system. |

Connecting the pump



A marking on the pump head indicates the flow direction.



Risk of injury due to mixing up inlet and outlet

Mixing up the inlet and outlet may cause breakage of components connected at the inlet and outlet.

→ Observe the marking of inlet and outlet on the pump head.

1. Remove the protective plugs from the hose connection threads.
2. Connect the suction line and the pressure line (for mounting dimensions, see Chapter 3 *Technical data*).
3. Lay the suction line and pressure line with a descent so that no condensate can run into the pump.



Pneumatic noises can be reduced or dissipated by using a silencer.



Secure the pressure-side connections with a fastener (e.g., hose/pipe clamp) to prevent the hoses from slipping down from the connection.

7 Operation

7.1 General



Risk of burns from hot pump parts and/or hot medium

Some pump parts may be hot during or after operation of the pump.

- Allow the pump to cool after operation.
- Take protective measures to protect against touching hot parts.



Risk of injury from bursting hoses during pressure applications due to excessively high temperatures

When operating the pump in pressure applications, hoses that are not designed for the head temperatures of the pump at the respective operating point could become porous and burst.

- Use temperature-resistant pressure hoses at the pneumatic connections.
- Wear protective equipment if necessary (e.g., safety gloves, hearing protection).



Injury to eyes

Coming too close to the inlet/outlet of the pump may result in injury to the eyes due to the present vacuum/operating pressure.

- Do not look into the pump inlet/outlet during operation.



Risk of injury from freely rotating shaft end

Touching the pump at the end of the shaft may result in injury through burning and crushing.

- Take protective measures to safeguard against touching moving and hot parts.
- Wear appropriate personal protective equipment if necessary.

- Only operate the pumps under the operating parameters and operating conditions as described in Chapter 3 *Technical data*.
- Ensure the proper use of the pumps (See Chapter 2.6.1 *Proper use*).
- Rule out the possibility of foreseeable misuse of the pumps (see chapter 2.6.2 *Foreseeable misuse*).
- Observe the safety instructions (Chapter 2 *Safety*).

- The pumps are built-in devices. Before they are commissioned, it must be ensured that the machines or systems into which the pumps are installed comply with the relevant provisions.



Risk of bursting of pump head due to excessive pressure increase

- Do not exceed the maximum permissible operating pressure (see 3 *Technical data*).
- Monitor the pressure during operation.
- If the pressure exceeds the maximum permissible operating pressure of the pump: Switch the pump off immediately and remedy the malfunction (see Chapter 10 *Störung beheben*).
- Only throttle or regulate the air or gas quantity on the inlet line to prevent the maximum permissible operating pressure from being exceeded.
- If the air quantity or gas quantity on the outlet line is throttled or regulated, make sure that the maximum permissible operating pressure at the pump is not exceeded.
- Ensure that the pump outlet is not closed or restricted.



Risk of dangerous gas mixtures during pump operation if diaphragm breaks

If the diaphragm should break, the medium will mix with the air in the compressor housing or in the surroundings.

- Stop pump immediately.
- Replace the diaphragm prior to further operation (see Chapter 8 *Servicing*).



NOTICE

Operation with open gas connection at the inlet can result in contaminants and objects being drawn in.

- Pump standstill → When the pump is at a standstill, establish normal atmospheric pressure in the lines.

Vapors as medium The service life of the diaphragm can be extended, if no condensate forms in the pump. Therefore:

- Perform any work with saturated or near-saturated vapors only with a warm pump.
- KNF recommends: When pumping corrosive media, flush the pump before switching off (see Chapter 8.2.1 *Flushing the pump*) to extend the service life of the diaphragm.

7.2 Information on switching the pump on and off

Switching on the pump

→ Ensure that normal atmospheric pressure is present in the lines when switching on.

Switching off/decommissioning the pump

→ Establish normal atmospheric pressure in the lines (relieve pump pneumatically).

Recommissioning → Before recommissioning, observe the applicable standards, guidelines, regulations and technical standards at the electrical connection.

Inspecting the pump → Inspect the pump periodically for external damage or leakage.

7.3 Control functions DC-B-M

7.3.1 Speed specification

Speed without external speed setting

The motor operates the pump at a non-variable speed over the entire permissible pressure range.

Speed with external speed setting

The motor operates the pump at a variable speed between n_{min} and n_{max} . The speed is specified by means of the control voltage (U_{ctrl}).

Specification of the speed is performed via the blue lead (see Tab. 14).

7.3.2 Speed output

The speed is output via the green lead (see Tab. 14).

The drive controller generates a speed-synchronous square frequency (see Fig. 8).

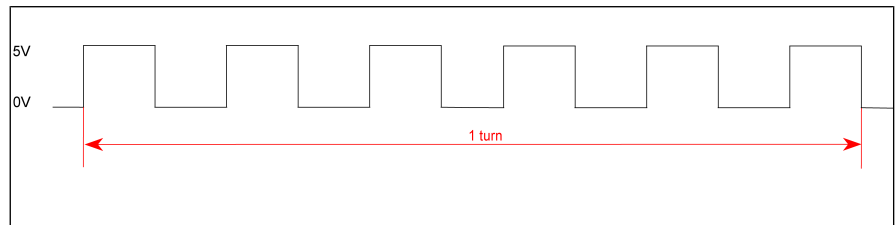

Fig.8 Speed output

7.3.3 Input signal for direction of motor rotation

The input signal for direction of motor rotation is applied via the yellow lead (see Tab. 14).

7.3.4 Input signal for remote ON/OFF

The input signal for remote ON/OFF is applied via the white lead (see Tab. 14).

8 Servicing



ESD-sensitive parts (ESDS)

Failure to observe the ESD protection provision acc. to IEC 61340-5-1 can result in total or partial damage to the pump.

- Maintenance of the pump may only be performed by a qualified person in an ESD-protected area (EPA) acc. to directive IEC 61340-5-1.



NOTICE

Servicing the pump

Damage to the pumps can result from failure to observe the applicable legal regulations and procedures for the location or intervention by untrained or uninstructed personnel.

- Servicing may only be performed according to the legal regulations (e.g. work safety, environmental protection) and provisions.
- Servicing may only be performed by specialized personnel or trained and instructed personnel.

8.1 Servicing schedule

Component	Servicing interval
Pump	<ul style="list-style-type: none"> → Perform periodic inspections for external damage or leakage. → Periodically check for noticeable changes to noises and vibrations.
Gas connections	<ul style="list-style-type: none"> → Perform periodic inspections for external damage or leakage.
Diaphragm and valve plates	<ul style="list-style-type: none"> → At the latest, replace when the pump flow rate decreases.
Silencer (accessories)	<ul style="list-style-type: none"> → Replace if soiled.

Tab. 15

8.2 Cleaning

8.2.1 Flushing the pump

When transferring dangerous and environmentally hazardous media, KNF recommends flushing the pump with air at atmospheric pressure for a few minutes prior to switch-off (if necessary for safety reasons: with an inert gas) to extend the service life of the diaphragm.

→ Discharge the media safely.

8.2.2 Cleaning the pump

Requirements → Pump disconnected from mains and voltage-free



CAUTION

Risk of burns from hot pump parts

The pump head or motor may still be hot after operation of the pump.

→ Allow the pump to cool after operation.



WARNING

Health hazard due to dangerous substances in the pump

Depending on the medium being transferred, caustic burns or poisoning is possible.

→ Wear protective equipment if necessary, e.g., protective gloves, goggles.

→ Clean the pump with suitable measures.



NOTICE

During cleaning work, ensure that no fluids enter the interior of the housing.

- Only clean the pump with a dry wiping cloth. When cleaning, use no solvents if possible as these can affect the plastic parts.
- Only use solvents during cleaning if head materials are not corroded (ensure resistance of the material).
- If compressed air is available, blow out the components.

8.3 Replacing diaphragm and valve plates

- Requirements
- Disconnect the pump from power and ensure that it is voltage-free.
 - Clean the pump and free the pump of hazardous materials.
 - Remove the pneumatic hoses from both the inlet and outlet of the pump.

Spare parts/tools	Spare part/tool	Quantity
	Spare part set*	1
	Torx TX10 screwdriver	1

Tab.16 *acc. to Chapter 9 Spare parts and accessories

Information on the procedure

Diaphragm and valve plates/seals are the only wear parts in the pumps. They are easy to replace.

Valve plates/seals and diaphragm should generally be replaced at the same time. If the diaphragm is not replaced at the same time as the valve plates/seals, the specified output of the pump can no longer be ensured after the maintenance is performed.



Health hazard due to dangerous substances in the pump

Depending on the medium being transferred, caustic burns or poisoning is possible.

- Wear protective equipment if necessary, e.g., protective gloves, goggles.
- Clean the pump with suitable measures.



Risk of burns from hot pump parts

The pump head or motor may still be hot after operation of the pump.

- Allow the pump to cool after operation.

The diaphragm and valve plates/seals are to be replaced in the following order:

- a.) Initial steps
- b.) Remove pump head
- c.) Replace diaphragm
- d.) Replace valve plates/seals
- e.) Mount pump head
- f.) Final steps

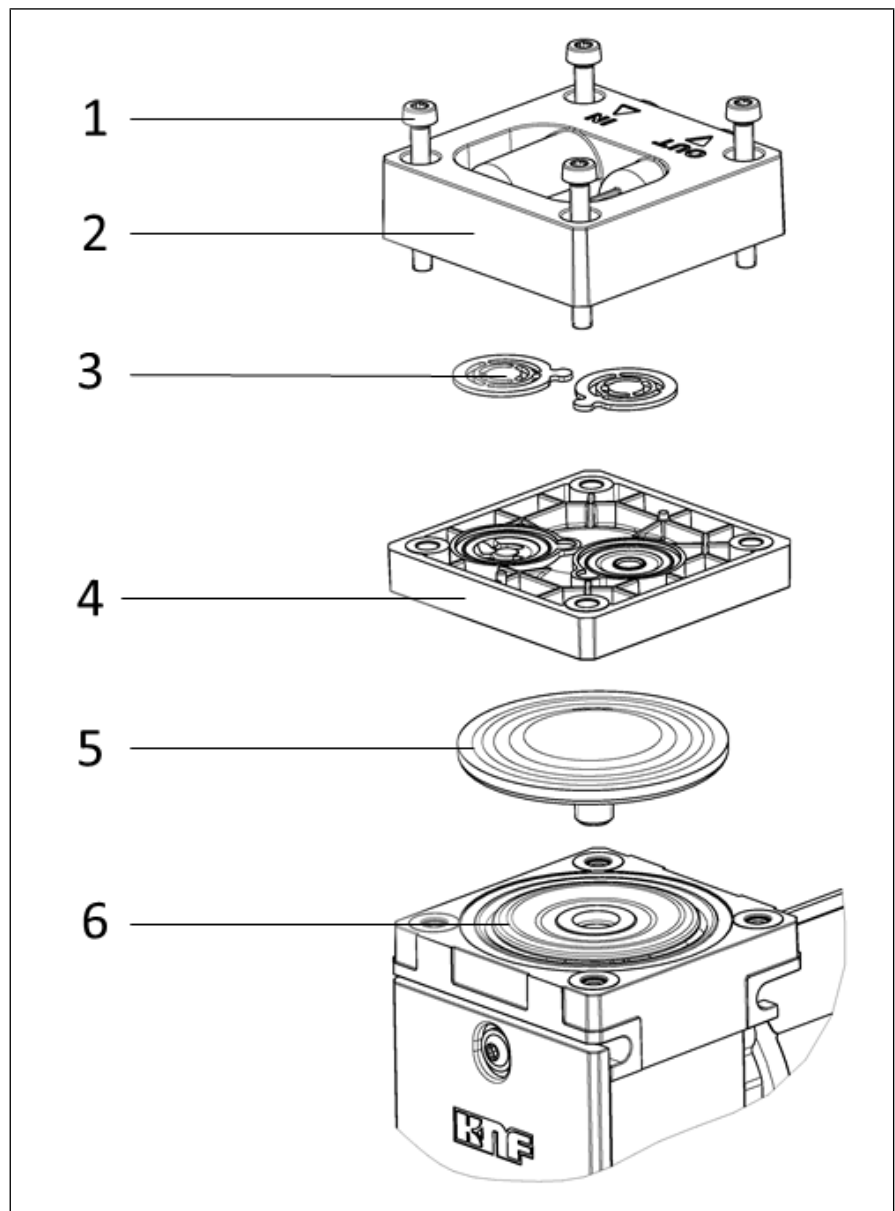

Fig.9 Exploded view (pump shown as an example)

The item numbers within the following work instructions refer to Fig. 9.

Proceed as follows:

a.) Initial steps

→ Disconnect the pump from the power supply and check and ensure that the pump is voltage-free.

b.) Remove pump head

→ Loosen the four head plate screws (1) and remove the head plate (2) from the pump housing together with the intermediate plate (4).

c.) Replace diaphragm

1. Lift the diaphragm (5) on opposing side edges. Then grasp the diaphragm (5) and move the diaphragm (5) to the upper reversal point. Unscrew the diaphragm (5) counterclockwise.
2. Check all parts for soiling and clean the parts if necessary (for further information, see Chapter 8.2 *Cleaning*).

3. Screw the new diaphragm (5) onto the connecting rod (6) (clockwise) and hand tighten the diaphragm (5).

i When screwing in the diaphragm (5), ensure that it is not overtightened.
If the diaphragm is overtightened, there is a risk that it could be damaged.

d.) Replace valve plates

1. Separate the head plate (2) from the intermediate plate (4).
2. Remove the valve plates/seals (3) from the head plate (2).
3. Check valve seats, intermediate plate and head plate for cleanliness; replace these parts in the event of unevenness, scratches or corrosion (contact your KNF Customer Service in this case).

i Insert new valve plates/seals in the valve seats of the intermediate plate; the valve plates/seals are identical for the pressure and suction side; the same applies for the top and bottom of the valve plates/seals.

4. By slightly moving the valve plates/seals horizontally, ensure that they are not under tension.
5. Make certain that the valve plates/seals are centered in the valve seats of the intermediate plate.

e.) Mount pump head

1. Place the intermediate plate (4) with valve plates/seals (3) on the housing.
2. Place head plate (2) on intermediate plate (4) according to the centering.

i Place pump head on the compressor housing according to the alignment of the gas connections.

3. Tighten the screws (1) crosswise (tightening torque: ~190 Ncm / 16.8 in-lb).

f.) Final steps



WARNING

Risk of injury and poisoning from leaks

→ Before recommissioning the pump, check the pump heads and pneumatic connections for leaks. Leaks may lead to poisoning, chemical burns or similar injuries.

→ Connect the pump to the power supply.

If you have questions with regard to maintenance, please contact your KNF Customer Service (contact data: see www.knf.com).

9 Spare parts and accessories

i To order spare parts and accessories, please contact your KNF sales partner or KNF Customer Service (contact data: see www.knf.com).

9.1 Spare parts

Spare part set

A spare part set consists of:

Parts	Item number*	Quantity
Diaphragm	(5)	1
Valve plates/seals	(3)	2

Tab.17 *see Chapter 8.3 Replacing diaphragm and valve plates

Spare part set	Order number
N96KN_	322637
N96KT_	322636
N96ATDC-B-M	322636
N96STDC-B-M	326868

Tab.18

9.2 Accessories

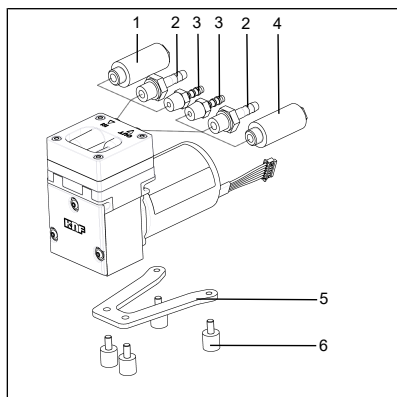

Fig.10 N96 accessories (pump depicted as an example)

Accessories	Item	Order number
Inlet filter	(1)	000346
Hose connector made of PVDF ID4	(2)	025671
Hose connector made of PVDF ID6	(2)	123363
Hose connector made of PP ID4	(3)	001936
Hose connector made of PP ID6	(3)	020185
Silencer / muffler	(4)	000345
Installation set (consisting of base plate and rubber-bonded metal)	(5), (6)	327888
Screw-in connection AD6x1		014049
Screw-in connection AD6		311072

Tab.19

10 Troubleshooting



Danger: electric shock can be life-threatening.

- All work on the pump may only be performed by an authorized specialist.
- Before working on the pump: Disconnect the pump from the power supply.
- Check and ensure that no voltage is present.

→ Allow the pump to cool before troubleshooting.

→ Check the pump (see following tables).

Pump not delivering	
Cause	Troubleshooting
Pump is not connected to the electrical mains.	→ Connect the pump to the electrical mains.
No voltage in the electrical mains.	→ Check the circuit breaker for the room and switch it on if necessary.
Pneumatic connections or lines are blocked.	→ Check the connections and lines. → Remove the blockage.
External valve is closed or filter clogged.	→ Check external valves and filters.
Condensation has collected in the pump head.	→ Separate the source of the condensation from the pump. → Flush the pump with air at atmospheric pressure for a few minutes (if necessary for safety reasons: with an inert gas). → Install the pump at the highest location in the system.
Max. voltage range of motor exceeded.	→ Disconnect pump from electrical mains. → The applied voltage must not exceed the value specified in Chapter 6.3 <i>Electrical connection</i> .
Incorrect polarity of the connection leads	→ Disconnect pump from electrical mains. → Ensure correct polarity of the connection leads and connect the pump.
Diaphragm and valves are worn or defective.	→ Replace diaphragm and valves (see Chapter 8 <i>Servicing</i>).

Tab.20

Flow rate, pressure or vacuum too low	
The pump does not reach the performance stated in the technical data or data sheet.	
Cause	Troubleshooting
Condensation has collected in the pump head.	<ul style="list-style-type: none"> → Separate the source of the condensation from the pump. → Flush the pump with air at atmospheric pressure for a few minutes (if necessary for safety reasons: with an inert gas). → Install the pump at the highest location in the system.
There is overpressure on the pressure side and at the same time vacuum or pressure above atmospheric pressure on the suction side.	<ul style="list-style-type: none"> → Change the pneumatic conditions.
Pneumatic lines or connection parts have insufficient cross-sections or are constricted.	<ul style="list-style-type: none"> → Disconnect the pump from the system to determine the output values. → Eliminate any constriction (e.g. valve). → Use lines or connection parts with a larger cross-section if necessary.
Leaks occur at pneumatic connections, lines or pump head.	<ul style="list-style-type: none"> → Eliminate the leaks.
Pneumatic connections or lines are partially or completely blocked.	<ul style="list-style-type: none"> → Check the pneumatic connections and lines. → Remove any parts or particles that are causing blockages.
Head parts are soiled.	<ul style="list-style-type: none"> → Clean the head components.
Working diaphragm broken	<ul style="list-style-type: none"> → Stop the pump immediately. → Change the diaphragm (see <i>8 Servicing</i>).
Diaphragm and valves are worn or defective.	<ul style="list-style-type: none"> → Replace diaphragm and valves (see Chapter <i>8 Servicing</i>).

Tab.21

Pump exhibiting changed running noises and vibrations	
Cause	Troubleshooting
Pump bearing worn or defective.	<ul style="list-style-type: none"> → Determine the cause. → Contact KNF Customer Service.

Tab.22

Fault cannot be rectified

If you are unable to identify any of the specified causes, send the pump to KNF Customer Service (contact data: see www.knf.com).

1. Flush the pump with air for a few minutes (if necessary for safety reasons: with inert gas) at atmospheric pressure to free the pump head of dangerous or aggressive gases (see Chapter *8.2.1 Flushing the pump*).
2. Clean the pump (see Chapter *8.2.2 Cleaning the pump*).
3. Send the pump together with completed Health and Safety Clearance and Decontamination Form to KNF, specifying the pumped medium.

11 Returns

Preparing for return

1. Flush the pump with air for a few minutes (if necessary for safety reasons: with inert gas) at atmospheric pressure to free the pump head of dangerous or aggressive gases (see Chapter 8.2.1 *Flushing the pump*).

i Please contact your KNF sales partner if the pump cannot be flushed due to damage.

2. Remove the pump.
3. Clean the pump (see Chapter 8.2.2 *Cleaning the pump*).
4. Send the pump together with the completed Health and Safety Clearance and Decontamination Form to KNF, stating the nature of the transferred medium.
5. Pack the device securely to prevent further damage to the product. If necessary, request original packaging for a fee.

Returns

KNF shall undertake to repair the pump only under the condition that the customer presents a certificate regarding the medium that is pumped and the cleaning of the pump. In this case too, old devices can be returned. Please follow the instructions at [knf.com/repairs here](https://www.knf.com/repairs).

Contact your KNF sales partner directly if you require additional support for your return service.

KNF worldwide

You can find our local KNF partners at: www.knf.com