

ATEX

**N680 EX
TRANSLATION OF ORIGINAL OPERATION AND
INSTALLATION INSTRUCTION
ENGLISH**

DIAPHRAGM PUMP

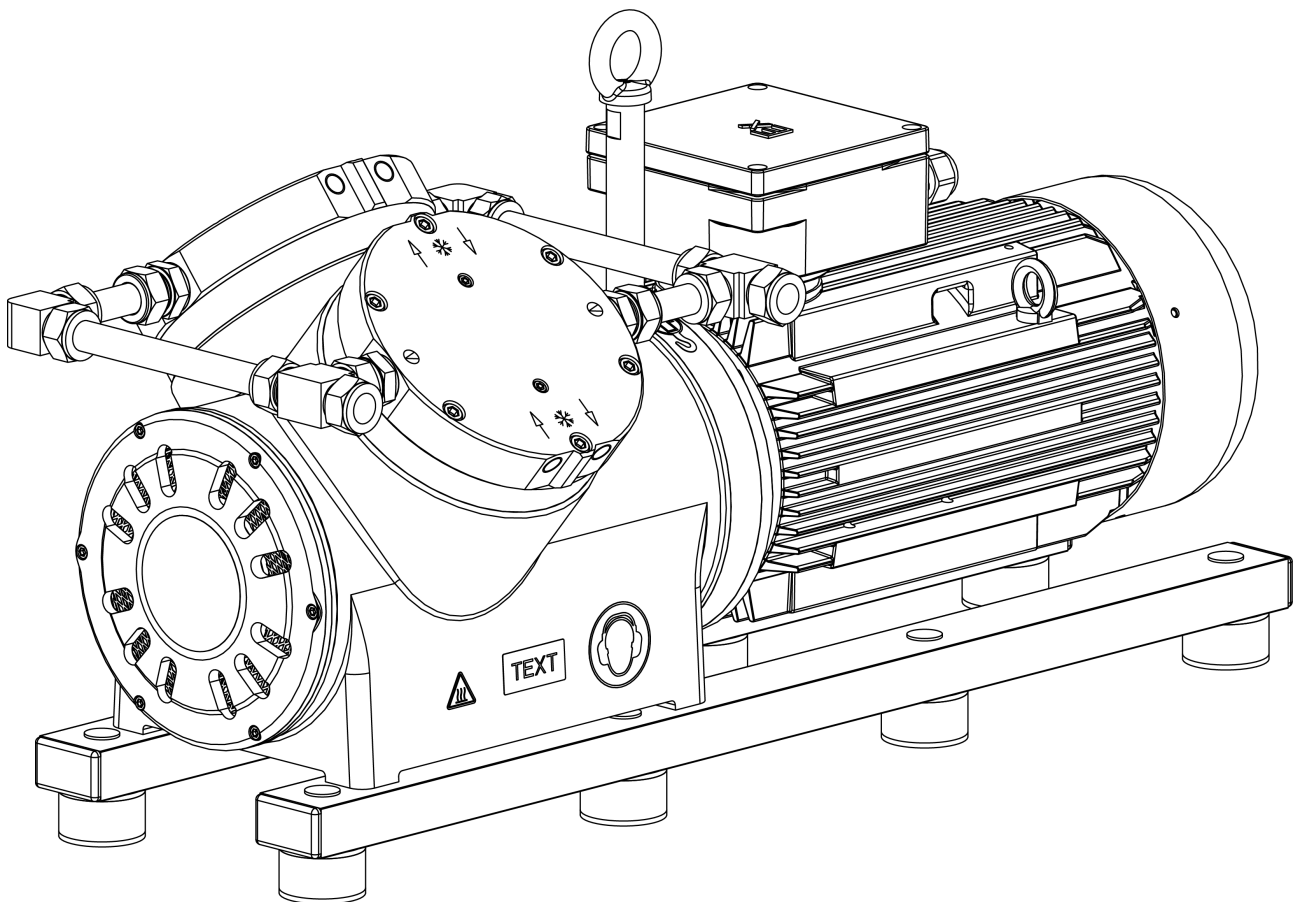

Notice!

Before operating the pump and accessories, read and observe the operating and installation instructions as well as the safety information!

KNF Neuberger GmbH
Alter Weg 3
79112 Freiburg
Germany
Tel. +49 (0)7664/5909-0
Fax. +49 (0)7664/5909-99

www.knf.com

Index

1	About this document	3
1.1	Using the operating and installation instructions.....	3
1.2	Exclusion of liability.....	3
1.3	Symbols and markings.....	4
2	Use.....	6
2.1	Proper use	6
2.2	Improper use	6
2.3	Use in potentially explosive areas.....	7
2.4	Explanations of the explosion protection designation	8
3	Safety	12
4	Technical data.....	14
4.1	Technical data.....	14
5	Product description and function.....	16
6	Transport.....	18
	General	18
	Transporting with lifting eyebolt	19
7	Installation and connection.....	20
7.1	Installing the pump.....	20
7.2	Electrical connection	22
7.3	Pneumatic connection.....	23
7.4	Connecting water cooling (optional).....	24
8	Operation	25
8.1	General	25
8.2	Information on switching the pump on and off	27
9	Servicing	28
9.1	Servicing schedule	28
9.2	Cleaning	30
9.3	Changing diaphragm and reed valves	31
9.4	Checking and replacing sprocket on coupling	37
10	Troubleshooting	41
11	Spare parts and accessories.....	44
11.1	Spare parts	44
11.2	Accessories.....	44
12	Returns.....	45
13	Appendix	46
13.1	Declaration of Conformity	46
13.2	Motor.....	51
13.3	Coupling.....	110

1 About this document

1.1 Using the operating and installation instructions

The operating and installation instructions are part of the pump.

- In the event of uncertainties with regard to the content of the operating and installation instructions, please contact the manufacturer (contact data: see www.knf.com). Please have the type and serial number of the pump ready.
- Read the operating and installation instructions before you commission the pump.
- Give the operating and installation instructions only completely and unchanged to the next owner.
- Keep the operating and installation instructions within reach at all times.

- | | |
|-------------------|---|
| Project pumps | For customer-specific project pumps (pump models that begin with "PJ" or "PM"), there may be deviations from the operating and installation instructions. <ul style="list-style-type: none"> → For project pumps, also observe the agreed specifications. → The deviations are listed in the accompanying specifications sheet (CPD). |
| Optional contents | Project-specific options may be included in the operating and installation instructions. These are marked as "optional". It is also possible that project-specific deviations may not be included in the operating and installation instructions. |
| Motor | The operating and installation instructions apply for the pump part. <ul style="list-style-type: none"> → Also observe the operating instructions for the motor in the appendix. |

1.2 Exclusion of liability

The manufacturer assumes no liability for damages and malfunctions resulting from failure to observe the operating and installation instructions.

The manufacturer assumes no liability for damages and malfunctions resulting from changes or modifications to the device and improper handling.

The manufacturer assumes no liability for damages and malfunctions resulting from impermissible spare parts and accessories.

1.3 Symbols and markings

Warning notice



A notice that warns you of danger is located here. Possible consequences of a failure to observe the warning notice are specified here. The signal word, e.g. warning, indicates the danger level.

→ Measures for avoiding the danger and its consequences are specified here.

Danger levels

Signal word	Meaning	Consequences if not observed
DANGER	warns of immediate danger	Death or serious injury or serious damage will result.
WARNING	warns of possible danger	Death, serious injury or serious damage is possible.
CAUTION	warns of a possibly dangerous situation	Minor injury or damage is possible.
NOTICE	warns of possible damage	Damage is possible.

Tab.1 Danger levels











Other notices and symbols

→ An activity to be carried out is specified here (a step).

1. The first step of an activity to be carried out is specified here. Follow other sequentially numbered steps.

i This symbol indicates important information.

Explanations of pictograms

Pictogram	Meaning
	General warning symbol
	Warning of hot surface
	Warning of electrical voltage
	Warning of explosive atmosphere
	Warning of poisonous substances
	Warning of hand injuries through crushing
	Observe the operating instructions
	General mandatory sign
	Wear hearing protection
	WEEE Symbol for separate tracking of electrical and electronic devices. The use of this symbol means that this product must be disposed of with normal household waste.

Tab.2 Explanations of pictograms

2 Use

2.1 Proper use

The pumps are intended exclusively for transferring gases and vapors.

Responsibility of the owner

Operating parameters and conditions Only install and operate the pumps in accordance with the operating parameters and conditions described in Chapter 4 *Technical data* and Chapter 2.3 *Use in potentially explosive areas*.

i Pumps with ATEX designation do not always satisfy the regulations for potentially explosive areas in countries outside of the EU.

Only pumps that are fully assembled and in the condition as delivered may be operated.

Make sure that the installation location is dry and that the pump is protected against rain, splash, gushing, and drip water as well as from other contaminants.

The pump is suitable for transferring potentially explosive atmospheres and for operation in potentially explosive atmospheres.

Check the tightness of the connections between the pipes of the application and the pump (or the connection of the pump) at regular intervals. Leaky connections carry the risk of releasing dangerous gases and vapors from the pump system.

Requirements on the transferred medium Before transferring a medium, check whether the medium can be transferred danger-free in the specific application.

Before using a medium, check the compatibility of the media-contacting components (see 4 *Technical data*) with the medium.

Risk of dangerous gas mixtures during pump operation if diaphragm breaks: Depending on the medium being transferred, breakage of the diaphragm can result in a dangerous mixture if the medium mixes with the air in the compressor housing or the surroundings.

Make certain that no risk of explosion arises even in extreme operating situations (temperature, pressure) and in the event of system breakdowns.

Only transfer gases that remain stable under the pressures and temperatures that arise in the pump.

Variable frequency drive Pumps with three-phase motor are designed for operation with a variable frequency drive in the speed range 500 – 1500 rpm (50 Hz) or 600 – 1800 rpm (60 Hz) (see also Chapter Electrical connection).

2.2 Improper use

The pumps are not suitable for use below ground.

The pumps are not suitable for delivering:

- Dusts
- Fluids
- Aerosols
- Biological and microbiological substances
- Explosives
- Fibers
- Foodstuffs.

Pumps that can produce both vacuum as well as overpressure may not be used to simultaneously produce vacuum and overpressure.

This function can be made possible on a project basis following consultation with KNF Customer Service.



No overpressure may be applied to the suction side of the pump.

This function can be made possible on a project basis following consultation with KNF Customer Service.

2.3 Use in potentially explosive areas

Only pumps and drives in the corresponding equipment category and temperature class may be operated in potentially explosive atmospheres (zones).

The pumps have the following EU explosion protection designation:

Designation	Description
	Symbol for explosion-proof pumps
II	Equipment group (see Chapter 2.4.1 <i>Device groups</i>)
2/2G	Device category (see Chapter 2.4.2 <i>Device categories for gas</i>)
Ex	Symbol indicates that the device complies with one or more ignition protection types
h	Symbol for ignition protection type (see Chapter 2.4.5 <i>Ignition protection type</i>)
IIB + H2	For SP design: Explosion groups (see Chapter 2.4.3 <i>Explosion groups</i>)
IIB	For ST design: Explosion groups (see Chapter 2.4.3 <i>Explosion groups</i>)
T3	Temperature class (see Chapter 2.4.4 <i>Temperature classes</i>)
Gb	Equipment protection level (See Chapter 2.4.6 <i>Equipment protection level for gas</i>)
	Special operating conditions (See Chapter 2.4.7 <i>Special operating conditions</i>)

Tab.3

An ignition hazard assessment in accordance with standards DIN EN ISO 80079-36 and DIN EN ISO 80079-37 was performed for the pumps. The protective goals were reached by applying ignition protection type constructional safety "c".

The explosion protection designation can also be found at the following location:

- Type plate of the pump

Drive The pump drive must have at least the same explosion protection as the pump.

2.4 Explanations of the explosion protection designation

2.4.1 Device groups

- Device group I Device group I applies for devices that are used in underground plants of mines as well as their underground systems that could be endangered by methane and/or combustible dusts.
- Device group II Device group II applies for devices that are used in other areas that could be endangered by an explosive atmosphere.

2.4.2 Device categories for gas

The device category describes the frequency and the duration of the occurrence of explosive atmospheres during operation.

Device category	Description
1G	Devices of this category are designed for use in areas in which an explosive atmosphere consisting of a mixture of air and gases, vapors or mists is present constantly or for long periods of time or often.
1D	Devices of this category are designed for use in areas in which an explosive atmosphere consisting of a dust/air mixture is present constantly or for long periods of time or often.
2G	Devices of this category are designed for use in areas in which it is to be expected that an explosive atmosphere consisting of gases, vapors or mists forms occasionally.
2/2G	Devices that extract from zone 1 and are designed for use in areas in which it is to be expected that an explosive atmosphere consisting of gases, vapors or mists forms occasionally.
2/-G	Devices that extract from zone 1 but are not designed for installation in a potentially explosive atmosphere (zone).
2D	Devices of this category are designed for use in areas in which it is to be expected that an explosive atmosphere consisting of a dust/air mixture forms occasionally.
3G	Devices of this category are designed for uses in areas in which it is to be expected that an explosive atmosphere resulting from gases, vapors or mists occurs, though in all likelihood occurs only seldom and for a very short length of time.
3/-G	Devices that extract from zone 2 but are not designed for installation in a potentially explosive atmosphere (zone).
3D	Devices of this category are designed for uses in areas in which it is to be expected that an explosive atmosphere resulting from stirred-up dust occurs, though in all likelihood occurs only seldom and for a very short length of time.

Tab.4

2.4.3 Explosion groups

Combustible gases and vapors are classified according to explosion groups (I, IIA, IIB and IIC) and temperature classes. The following table shows the classification of the most common combustible gases and vapors.

	T1	T2	T3	T4	T5	T6
I	Methane	–	–	–	–	–
IIA	Acetone Ethane Ethyl acetate Ammonia Ethyl chloride Benzene Acetic acid Carbon monoxide Methane Methanol Methyl chloride Naphthalene Phenol Propane Toluene	i-amyl acetate n-butane n-butyl alcohol Cyclohexanone 1,2-dichloroethane Acetic anhydride	Gasoline Diesel fuel Jet fuel Heating oils n-hexane	Acetaldehyde	–	–
IIB	Town gas	Ethylene Ethyl alcohol	Hydrogen sulfide	Ethyl ether	–	–
IIC	Hydrogen	Acetylene	–	–	–	Carbon disulfide

Tab.5

The classification of gases and vapors into groups with respect to explosion group and temperature class applies for the transferred medium as well as for the pump surroundings.

Transferred medium The device must only be used to transfer gases and vapors that belong to the respective explosion group and the corresponding temperature class (or lower), (see designation on the type plate) or which are not explosive and not combustible.

Surroundings of the device The devices may only be operated in an environment with an atmosphere that belongs to the respective explosion group and the corresponding temperature class (or below) (see designation on the type plate) or which is not explosive and not combustible.

2.4.4 Temperature classes

- Maximum surface temperature The maximum surface temperature is the highest temperature reached by a surface of the device under the most unfavorable conditions.
- Ignition temperature The maximum surface temperature of the device must always be lower than the lowest ignition temperature of the gas/air or vapor/air mixture in which it is used.
- Temperature class The maximum surface temperature is derived from the construction of the device and is stated as the temperature class.

Temperature class	Max. surface temperature [°C]	Ignition temperature [°C]
T1	450	> 450
T2	300	> 300
T3	200	> 200
T4	135	> 135
T5	100	> 100
T6	85	> 85

Tab.6

The temperature class of the pump was determined using air. If gas mixtures consisting mainly of gases with a greater isentropic exponent than that of air (helium, argon, xenon, neon, krypton) are pumped, compressing these mixtures can give rise to higher gas temperatures, and consequently higher surface temperatures as well. This must be taken into account and if necessary tested before operating the pump. When gas mixtures of this kind are pumped, it is recommended to run the pump with water cooling connected.

2.4.5 Ignition protection type

Designation	Description
h	Constructional safety "c"
h	Ignition source monitoring "b"
h	Liquid immersion "k"

Tab.7

An ignition hazard evaluation according to the standards DIN EN ISO 80079-36 and DIN EN ISO 80079-37 was carried out for the devices. The protective goals were reached by applying ignition protection type constructional safety "c".

2.4.6 Equipment protection level for gas

The equipment protection level describes the frequency and the duration of the occurrence of explosive atmospheres in an area.

Equipment protection level	Description*	Constructional safety
Ga	Devices with very high protection level for use in potentially explosive areas. With these devices, there is no risk of ignition during normal operation or in the event of foreseeable or infrequent faults/malfunctions.	Very high
Gb	Devices with high protection level for use in potentially explosive areas in which there is no risk of ignition during normal operation or in the event of foreseeable or infrequent faults/malfunctions.	High
Gc	Device with increased protection level for use in potentially explosive areas. There is no risk of ignition during normal operation. The devices have a number of additional protection measures which ensure that, in the event of commonly foreseeable faults in the device, no danger of ignition exists.	Increased

Tab.8 *according to DIN EN ISO 80079-36

2.4.7 Special operating conditions

- The devices must not be installed outdoors. Commissioning may only be performed with suitable weather- and corrosion-protection paneling.
- The devices must be installed in a way that ensures they are not exposed to UV radiation.

3 Safety

i Observe the safety notices in Chapters 7 *Installation and connection* and 8 *Operation*.

The pumps are produced in accordance with the generally recognized rules of engineering, as well as the occupational health, safety and accident prevention regulations. Nevertheless, dangers can arise during their use that lead to injuries to the user or third parties or to damage to the pump or other property.

Only use the pumps in perfect technical condition, for their intended purpose, safely and aware of the dangers and in observation of the operating instructions.

The components that are to be connected to the pumps must be designed according to the pneumatic data of the pumps.

When connecting the pumps to the electrical power, observe the corresponding safety rules.

Personnel Make sure that only specially trained personnel or trained and instructed personnel work on the pumps. This applies in particular for connection and maintenance work.

Make sure that the personnel have read and understood the operating instructions, particularly the chapter on safety.

Working in a safety conscious manner Observe the regulations on accident prevention and safety during all work on the pumps and during operation.

Avoid contact with the heads and housing parts, as the pump heats up during operation and may remain hot for some time after operating.

When working on the pump, make certain that the pump is disconnected from mains and without power.

Ensure that no hazards arise from gas flowing when gas connections are open, from the effects of noise or from hot, corrosive, dangerous and environmentally hazardous gases.

Classification of a pump environment When classifying a pump environment in a potentially explosive area (zone), observe the "Guideline for Preventing Danger from Explosive Atmospheres, with a Collection of Examples – Explosion Protection Guidelines – (EX-RL)".

For special cases or if there are doubts about the definition of potentially explosive atmospheres, inform the supervisory authorities and ask them to make a decision.

Use in potentially explosive environment The following applies for use in a potentially explosive environment consisting of gases, vapors and mists:

The lowest ignition temperature of the potentially explosive atmospheres that comes into question must be higher than the so-called "maximum surface temperature" of the pump.

According to DIN EN ISO 80079-36, the maximum surface temperature is the highest temperature that is achieved during operation under the most unfavorable conditions (but within the accepted tolerances) of a part or on a surface of the pump.

The maximum surface temperature is determined as a function of the pump design and is indicated on the pump type plate as the temperature class.

Explosion protection The introduction of ignition sources such as sparks, open flames and hot surfaces into potentially explosive atmospheres can cause explosions.

Therefore, when transporting, installing, and performing any work on the device in a potentially explosive atmosphere:

- Only perform work when there is no possibility of a potentially explosive atmosphere.

4 Technical data

4.1 Technical data

Pump materials

Assembly	Material
Head plate, intermediate plate	Stainless steel
Diaphragm: ST design SP design	PTFE-coated EPDM
Reed valves	Stainless steel
Valve limiter	Stainless steel
Slotted cap screw	Stainless steel
O-ring	FPM
Conrod plate	Aluminum
Retainer plate	Stainless steel
Connection	Stainless steel
PTFE disk	PTFE

Tab.9

Pneumatic values

Parameter	Value N680.1.2
Max. permissible operating pressure [bar rel*] -Continuous operation	3,0
Ultimate vacuum [mbar abs.]	150
Flow rate at atm. pressure [l/min]** -50 Hz	220

Tab.10 *Bar rel related to 1013 hPa

**Liters in standard state (1013 hPa, 20 °C)

Pneumatic connections

Pump type	Value
N680.1.2	For hose Ø 18

Tab.11 *Acc. to ISO 228

Connection for water cooling

Pump type	Value
N680.1.2	Hose ID9

Tab.12 *Acc. to ISO 228

Other parameters

Parameter	Value
Permissible ambient temperature [°C]	+5 to +40
Permissible media temperature [°C]	+5 to +40
Dimensions N680.1.2 EX	See , Chapter 7.1 <i>Installing the pump</i>
Gas tightness* of the pump head	< 6 x 10 ⁻³ mbar l/s
Protection class of pump	IP 20
Noise**	< 95 dB (A)

*Tab.13 * The gas tightness of the pump head is no longer ensured after the pump head is opened or after replacing diaphragm and valve plates/seals. A leak test can be used to determine whether the original gas tightness is achieved again.*

***Max. emission sound pressure level over the entire pressure range with gas connections attached*

Electrical data

Parameter	Value
Voltage [V]	See drive type plate
Frequency [Hz]	
Power P ₁ [W]	
Max. current consumption [A]	
Drive protection class	
Fuse (PTC thermistor sensor)	See type plate and operating instructions for drive
Max. permissible line voltage fluctuations	See operating instructions for drive
Relative air humidity	80% for temperatures to 31 °C, decreasing linearly to 50% at 40 °C (non-condensing).
Max. installation altitude	See operating instructions for drive

Tab.14

Weight

Pump type	Value [kg]
N680.1.2	Approx. 101

Tab.15

Coupling

Parameter	Value
EX-designation	II 2G h IIC T6...T4 Gb
Size	24

Tab.16

5 Product description and function

Design

- 1 Union nut
- 2 Connection for water cooling
- 3 Pneumatic head connection
- 4 Pneumatic pump inlet
- 5 Motor
- 6 Motor fan cover
- 7 Electrical terminal box
- 8 Pneumatic pump outlet

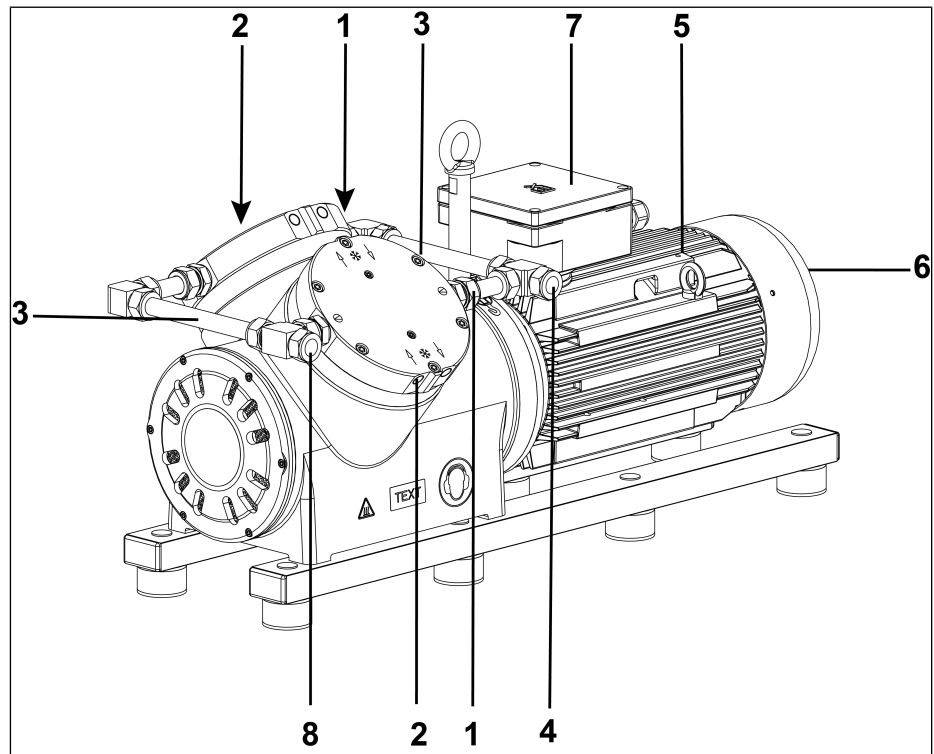

Fig.1 Design N680.1.2 EX

Function of a diaphragm pump

- 1 Outlet valve
- 2 Inlet valve
- 3 Transfer chamber
- 4 Diaphragm
- 5 Eccentric
- 6 Connecting rod

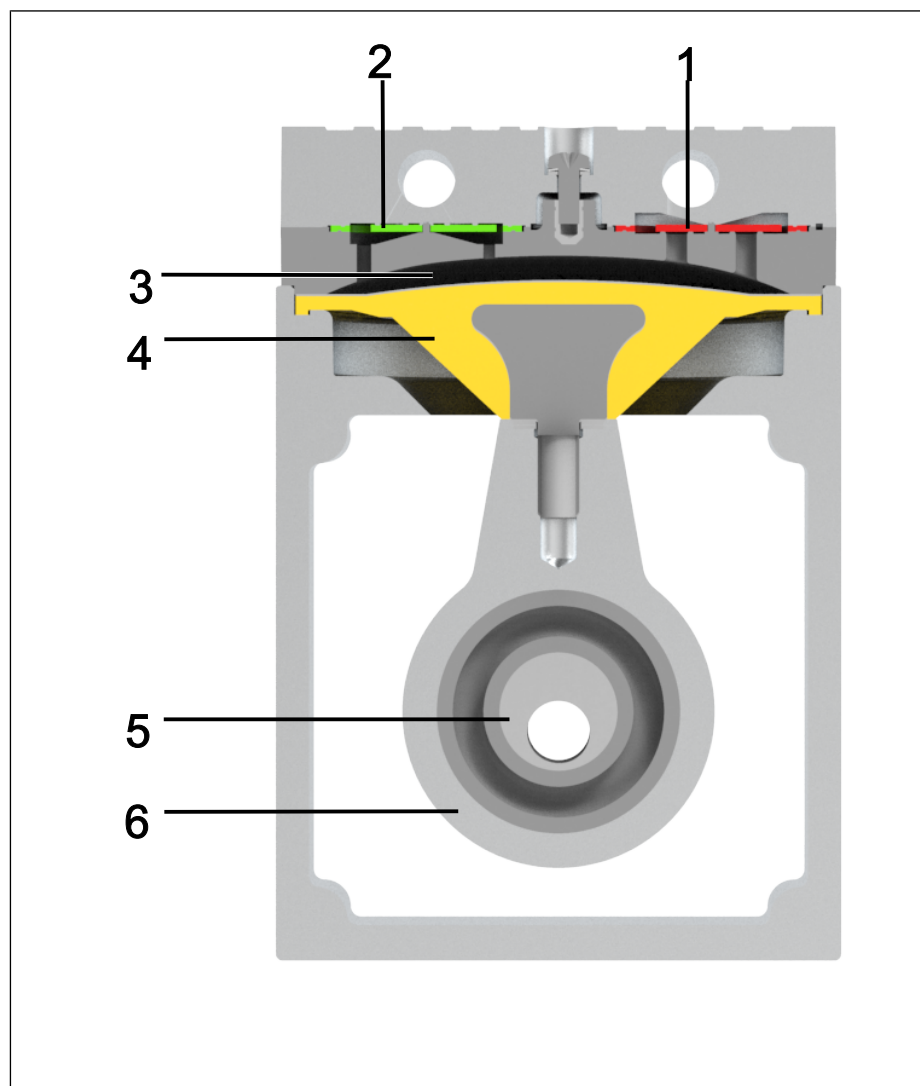

Fig.2 Function of a diaphragm pump

Diaphragm pumps transfer, compress (depending on the version) and evacuate gases and vapors.

The elastic diaphragm (4) is moved up and down by the eccentric (5) and the connecting rod (6). In the downwards stroke, it aspirates the gas to be transferred via the inlet valve (2). In the upwards stroke, the diaphragm presses the medium out of the pump head via the outlet valve (1). The transfer chamber (3) is separated from the pump drive by the diaphragm.

6 Transport

General



Personal injury and/or property damage due to incorrect or improper transport of the pump

In the event of incorrect or improper transport, the pump can fall down, be damaged or injure persons.

- Use suitable auxiliary means if necessary (carrying strap, lifting gear, etc.).
- Where appropriate, wear suitable personal protective equipment (e.g., safety shoes, safety gloves).



Risk of injury from sharp edges on the packaging

There is a risk of injury from cutting on the sharp edges when grabbing corners or when opening the packaging.

- Where appropriate, wear suitable personal protective equipment (e.g., safety shoes, safety gloves).

- Transport the pump in the original packaging to the installation location.
- Store the original packaging of the pump (e.g. for later storage).
- Inspect the pump for transport damage after receiving it.
- Document any transport damage in writing.
- Remove any transport locking devices on the pump prior to commissioning.

Parameter

Parameter	Value
Storage temperature [°C]	+ 5 to + 40
Transport temperature [°C]	- 10 to + 60
Permissible humidity (non-condensing) [%]	30 to 85
Max. storage period (Aging, ball-bearing grease) [Mon.]	48

Tab.17 Transport parameter and storage parameter



Prior to commissioning, make sure that the pump has reached the ambient temperature (*4 Technical data*).

Transporting with lifting eyebolt

1. Loosen the M12 screw (1).

1 M12 screw

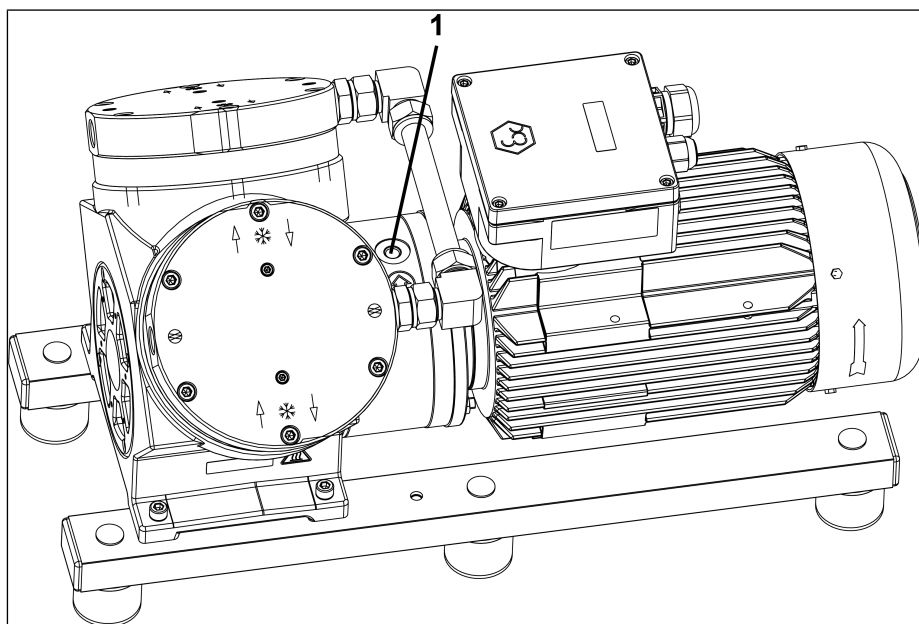

Fig.3 Loosen the M12 screw (pump illustrated as an example)

2. Screw the transport eyebolt (2) hand-tight into the threaded hole.

i The transport eyebolt (2) is available as an accessory (see 11.2 Accessories).

2 Transport eyebolt

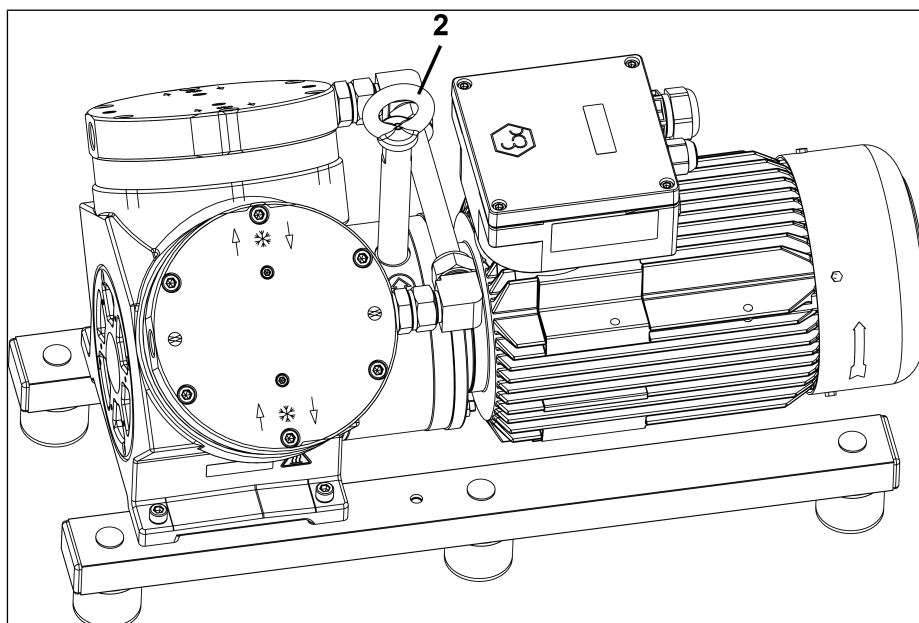

Fig.4 Transport eyebolt (depicted pump as an example)

3. Lift the pump out of the packaging with the aid of lifting gear.
4. Lower the pump carefully at the installation location.
5. Remove the transport eyebolt (2).
6. Screw the M12 screw (1) back into the thread.

7 Installation and connection

The pumps are only to be installed in accordance with the operating parameters and conditions described in Chapter 4 *Technical data*.

→ Observe the safety notices (see Chapter Safety).



Risk of dangerous gas mixtures during pump operation

Depending on the medium being transferred, breakage of the media-contacting components can result in a dangerous mixture if the medium mixes with the air in the compressor housing or the surroundings.

→ Before using a medium, check the compatibility of the media-contacting components (see 4 *Technical data*) with the medium.

7.1 Installing the pump

→ Store the pump at the installation site prior to installation to bring it up to the ambient temperature.

Mounting dimensions → For mounting dimensions, see following figures:

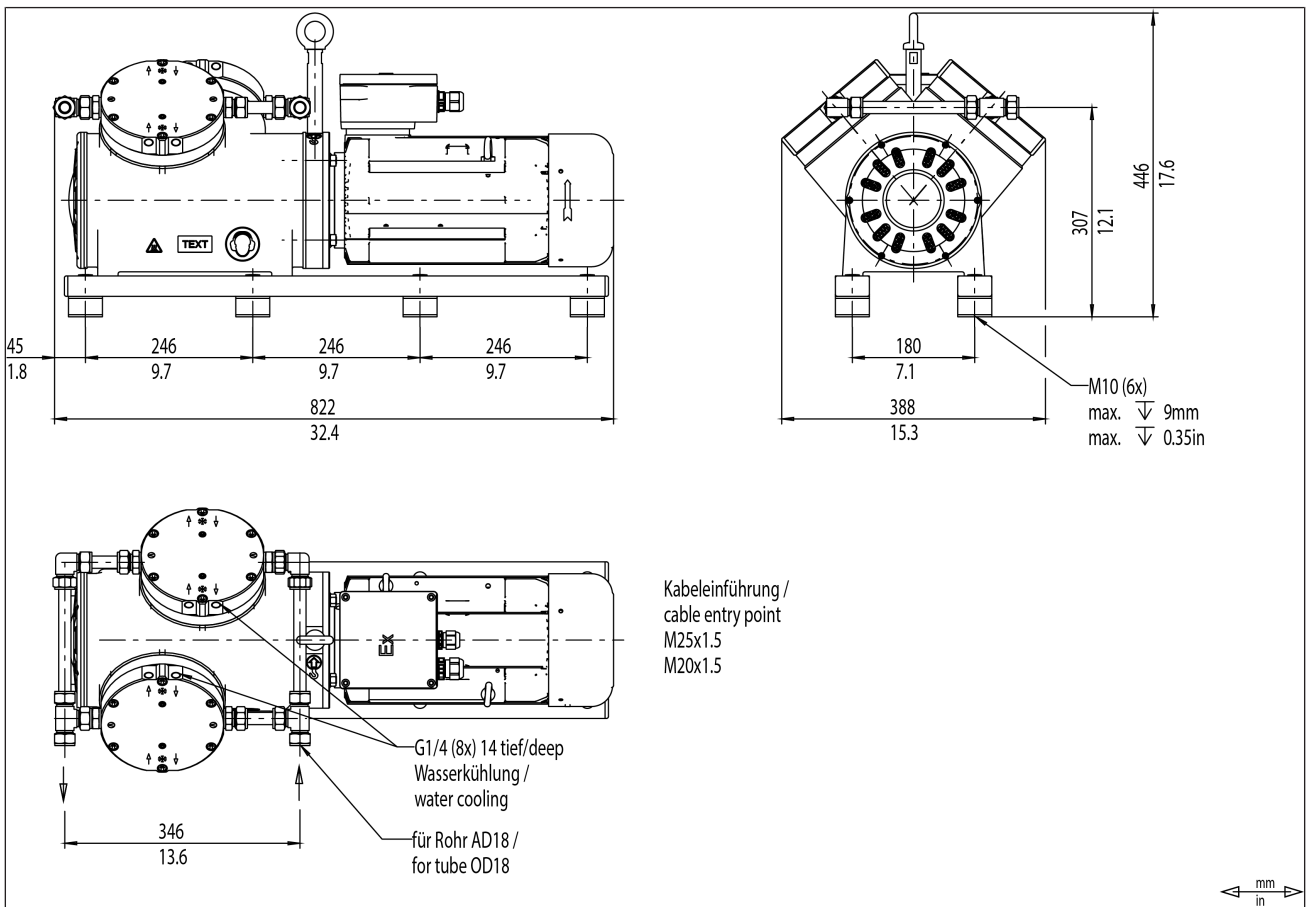

Fig.5 Mounting dimensions N680.1.2 EX

Cooling air supply



Risk of explosion due to lack of cooling air supply

- Mount the pump so that the fan wheel of the pump can draw in sufficient cooling air.
- Ensure sufficient ventilation or heat dissipation in the vicinity of the pump.



Danger of burning on hot surfaces

Hot surfaces could occur if the pump overheats.

- When installing the pump, make sure that sufficient cooling air infeed and discharge is ensured.

Immediate environment of the hot pump parts

- During installation, make sure that no combustible or thermally deformable objects are positioned in the immediate proximity of the hot pump parts (head, drive).

Installation location

- Make sure that the installation location is dry and that the pump is protected from rain, spray water, splash water, dripping water and other contaminants.

- Make sure that the installation location is accessible for service.

- Make sure that access to moving parts is prevented.

i The IP protection class of the pump motor is specified on the type plate.

- Mount the pump at the highest point in the system to prevent condensate from collecting in the pump head.

- Protect the pump from dust.

- Protect the pump from vibration and impact.



Personal injury and/or property damage from vibrations

Pump vibrations, in combination with adjacent components, can result in crushing and/or damage to these components.

- Make sure that pump vibrations cannot lead to dangers in combination with adjacent components.

7.2 Electrical connection



DANGER

Danger to life from electric shock

- Only have the pump connected by an authorized specialist.
- Only have the pump connected if the power supply is disconnected.



WARNING

Risk of explosion from electrostatic charge

- Connect the pump so that the risk of ignition from electrostatic charge is avoided.
- Carefully ground the pump.

- When connecting to a power source, carefully read and observe the motor operating instructions (including the notice on insulation resistance measurement).
- When connecting to a power source, observe the applicable regulations, directives, and technical standards.



WARNING

Automatic restart after interruption of the power supply

If the power supply is interrupted or the thermal overload fuse of the motor is activated, the pump will automatically restart.

- Take appropriate protective measures.

- Install a device for separating the pump motor from the electrical mains in the electrical installation.
- Install an Emergency Off device such that it is not possible for there to be an automatic restart or for hazardous situations to persons and property to occur.

Potentially explosive atmospheres

- Only place the electrical equipment that is necessary for the operation of the pump .

- Take lightning protection measures.

Fastening the connection cables

- Fasten the connection cables so that
 - the cables do not come into contact with movable or hot parts.
 - the cables cannot be worn or damaged on sharp corners or edges
 - no tensile and pressure forces are exerted on the connection point of the cables (strain relief)

7.3 Pneumatic connection



Personal injury or property damage through ejected plugs

If not removed, the plugs on the pressure side of the pump can be ejected during operation by the resulting overpressure.

- Remove the plugs during installation.
- Wear appropriate personal protective equipment.

- Connected components → Only connect components to the pump that are designed for the pneumatic data and thermal requirements of the pump. (see Chapter 4 *Technical data*).
- Pressure relief device → Protect the compressors by means of a pressure relief device between the pressure-side connections of the compressor and the first shut-off valve.



Risk of explosion during pressure limitation resulting from the medium mixing with the environment

- Make certain that there is no risk of explosion posed by the medium mixing with the environment.

- Pump discharge → If the pump is used as a vacuum pump, safely (with respect to medium and noise) drain the hot pump discharge that may, under certain circumstances, occur at the pneumatic outlet of the pump.
- Decoupling → KNF recommends mechanically decoupling the pump from the pipe system, e.g., through the use of flexible hoses or pipes. In this way it is possible to prevent the transfer of possible pump vibrations and noises to the system.

Connecting the pump



A marking on the pump head indicates the flow direction.



Risk of injury from mixing up suction side and pressure side

Mixing up the suction side and pressure side can result in breakage of connected components on the suction side and pressure side.

- Observe the marking of inlet and outlet on the pump head.

1. Remove the protective plugs from the gas connection threads.
2. Connect the suction line and the pressure line (for mounting dimensions, see Chapter 4 *Technical data*).
3. Lay the suction line and the pressure line at a downward angle to prevent condensate from running into the pump.

7.4 Connecting water cooling (optional)

i Water cooling (see 11.2 Accessories) can increase the service life of the diaphragm, particularly with high pressures or high ambient temperature.

Operating parameters

Parameter	Value
Water temperature [°C]	+ 5 to + 30
Water pressure [bar g]	< 1.0
Water flow rate [l/min]	> 1.0

Tab.18 Recommended parameters for connecting the water cooling

1. Connect the water cooling system to the provided hose connections.

→ Safely drain the water discharge.

i The flow direction is allowed in both directions.

Mounting dimensions For mounting dimensions, see the following dimensional drawings:

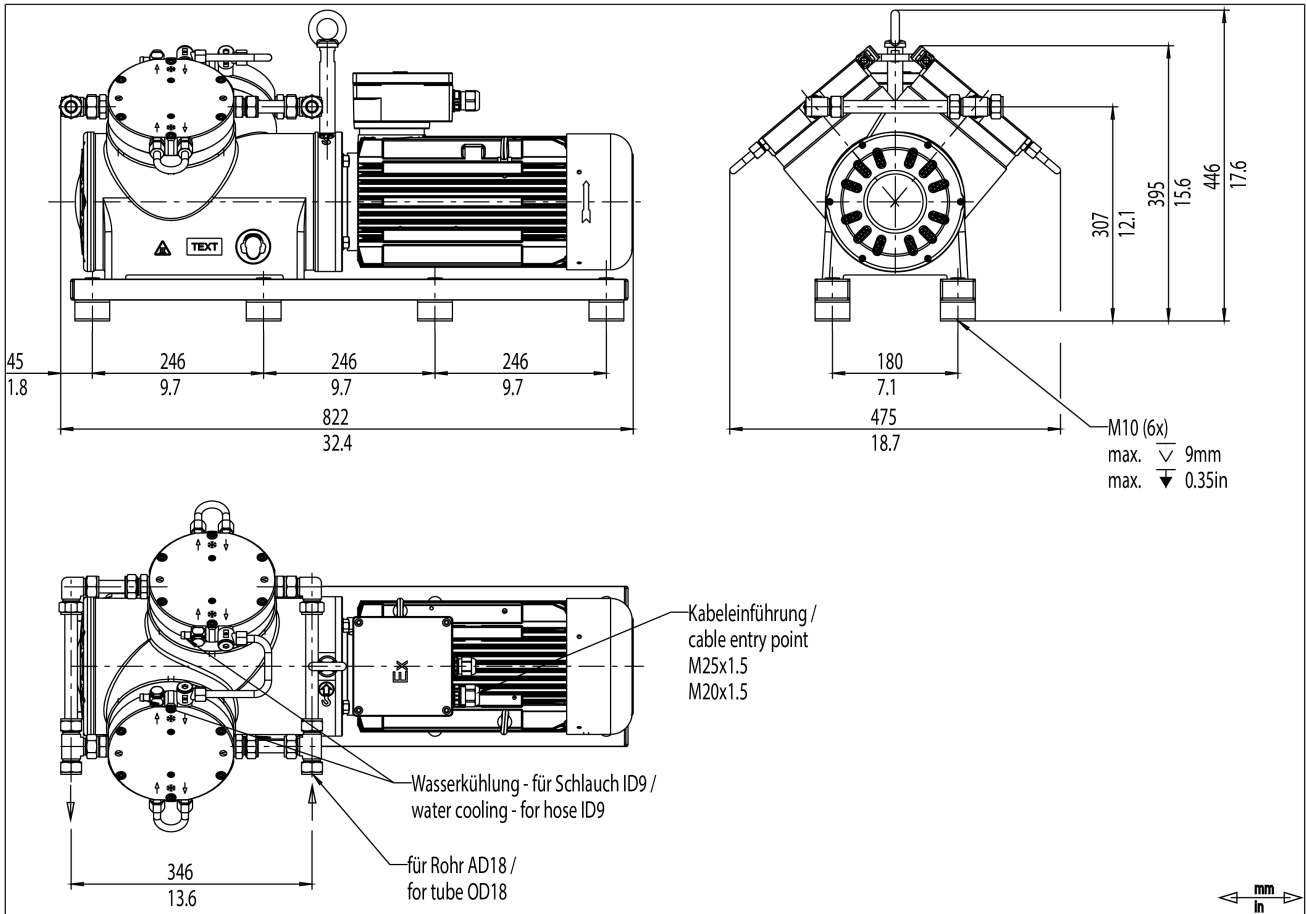

Fig.6 Mounting dimensions N680.1.2 EX

8 Operation

8.1 General



Risk of burns from hot pump parts and/or hot medium

Some pump parts may be hot during or after operation of the pump.

- Allow the pump to cool after operation.
- Take protective measures to protect against touching hot parts.



Damage to the pump due to overheating

If gases with a greater isentropic exponent than that of air (helium, argon, xenon, neon, krypton) are pumped, compressing these gases gives rise to higher gas temperatures. The higher temperatures may impair the functional capabilities of the parts of the pump that are in contact with the media and possibly also adjacent components (e.g., ball bearings). This in turn will shorten the service life of the pump.

- If necessary, contact KNF Customer Service.



Risk of explosion due to excessively high surface temperature

The temperature class of the pump was determined using air. If gas mixtures consisting mainly of gases with a greater isentropic exponent than that of air (helium, argon, xenon, neon, krypton) are pumped, compressing these mixtures can give rise to higher gas temperatures, and consequently higher surface temperatures as well.

- Before pumping gas mixtures of this kind, check the surface temperature before running the pump.
- When pumping gas mixtures of this kind, run the pump with water cooling connected.



Injury to eyes

Coming too close to the inlet/outlet of the pump may result in injury to the eyes due to the present vacuum/operating pressure.

- Do not look into the pump inlet/outlet during operation.

- Only operate the pumps in accordance with the operating parameters and operating conditions described in Chapter 4 *Technical data* and in Chapter 2.3 *Use in potentially explosive areas*.
- Ensure the proper use of the pumps (See Chapter 2.1 *Proper use*).
- Eliminate the possibility of improper use of the pumps (see Chapter 2.2 *Improper use*).
- Observe safety notices (Chapter 3 *Safety*).



Risk of pump head bursting due to excessive pressure increase

- Do not exceed the maximum permissible operating pressure (see 4 *Technical data*).
- Monitor the pressure during operation.
- If the pressure exceeds the maximum permissible operating pressure of the pump: immediately switch off the pump and remedy the fault (see Chapter *Troubleshooting*).
- Only throttle or regulate the air or gas quantity on the suction line to prevent the maximum permissible operating pressure from being exceeded.
- If the air quantity or gas quantity on the pressure line is throttled or regulated, make sure that the maximum permissible operating pressure at the pump is not exceeded.
- Ensure that the pump outlet is not closed or restricted.



Risk of explosion from elevated ambient temperature

- Monitor the ambient temperature (compression heat, motor heat).
- Ensure sufficient cooling air supply.



Risk of dangerous gas mixtures during pump operation if diaphragm breaks

If the diaphragm should break, the medium will mix with the air in the compressor housing or in the surroundings.

- Stop pump immediately.
- Replace the diaphragm prior to further operation (see Chapter 9 *Servicing*).

i Because the diaphragm is a wear part, diaphragm breakage may occur at any time.

- Pump standstill → When the pump is at a standstill, establish normal atmospheric pressure in the lines.

- Vapors as medium → The service life of the diaphragm can be prolonged if condensation does not form in the pump. Therefore, only carry out work with saturated or near-saturated vapors while the pump is warm.
- i** Operation with open suction-side gas connection can result in contaminants and objects being drawn in.

8.2 Information on switching the pump on and off

Switching on the pump



Caution: Damage to hearing

When the pump is in operation, loud noises may be created (see 4 *Technical data*) (>85 dB (A)), which may lead to hearing damage.

- The pump must be disconnected from all other components when setting up.
- Do not operate the pump unless it is fully connected, or use a silencer.
- Wear personal protection equipment (e.g., hearing protection).

-
- Ensure that there is normal atmospheric pressure in the lines when switching on.

Switching off the pump

- KNF recommends: When pumping corrosive media, flush the pump before switching off (see Chapter 9.2.1 *Flushing the pump*) to extend the service life of the diaphragm.
 - Establish normal atmospheric pressure in the lines (relieve pump pneumatically).
- Recommissioning → Before recommissioning, observe the applicable standards, guidelines, regulations and technical standards at the electrical connection.
- Inspecting the pump → Inspect the pump periodically for external damage or leakage.

9 Servicing



NOTICE

Servicing the pump

Damage to the pumps can result from failure to observe the applicable legal regulations and procedures for the location or intervention by untrained or uninstructed personnel.

- Servicing may only be performed according to the legal regulations (e.g. work safety, environmental protection) and provisions.
 - Servicing may only be performed by specialized personnel or trained and instructed personnel.
-

9.1 Servicing schedule



WARNING

Risk of explosion from wear

- Have the connecting rod bearing replaced by KNF according to servicing schedule.
 - Have the motor bearing replaced by KNF according to servicing schedule.
-



WARNING

Risk of explosion if genuine spare parts are not used.

If original parts are not used, the pump loses its explosion protection properties. Furthermore, the function of the pump and its safety are lost. The validity of the CE conformity is rendered void if genuine spare parts are not used.

- Use only genuine spare parts from KNF when performing servicing work.
-

Component	Servicing interval
Pump	<ul style="list-style-type: none"> → Perform periodic inspections for external damage or leakage. → Periodically check for noticeable changes to noises and vibrations.
Diaphragm and reed valves or valve plate(s)	→ At the latest, replace when the pump flow rate decreases
Pump bearing (on pump shaft and connecting rod)	→ Replace after 34,000 operating hours or after no more than 48 months
Motor bearing	→ See the operating and installation instructions for the motor; inquire with the manufacturer of the motor if necessary
Gas connections	→ Inspect the pump periodically for external damage or leakage
Coupling	<ul style="list-style-type: none"> → Inspect coupling play periodically → See operating instructions for coupling

Tab. 19

The ball bearings installed in the pump and in the drive motor are lubricated for life. This means that the bearings are coated with a high-quality grease with a high degree of purity and an ideal fill level by the bearing manufacturer at the plant. These bearings cannot be relubricated. The prescribed bearing replacement periods can be found in Chapter 9.1 *Servicing schedule*.

The duration of use of the bearing grease depends on many highly individual factors. The prescribed bearing replacement periods were specified under the assumption of normal ambient conditions. Factors that can make early bearing replacement necessary include dust or dirt that may get into the bearing, aggressive gases or vapors that may change the lubricating properties of the bearing grease, etc. It is the operator's responsibility to assess these factors.

9.2 Cleaning

9.2.1 Flushing the pump



Risk of explosion by flushing the pump with air

- In potentially explosive areas or when using the pump with explosive media, only permit specialist to flush the pump with inert gas.



Risk of burns from hot pump parts and/or hot medium

Some pump parts may be hot during or after operation of the pump.

- Allow the pump to cool after operation.
- Take protective measures to protect against touching hot parts.

- Before switching off the pump under atmospheric conditions, flush for several minutes with inert gas.

i If there is no risk of explosion, flushing can also be performed with air.

- Discharge the media safely.

9.2.2 Cleaning the pump



Risk of explosion from electrostatic charging of the components

- Only clean the pump with a damp cloth.

- Only clean the pump with a damp cloth and non-flammable cleaning agents.
- Only use solvents during cleaning if head materials are not corroded (ensure resistance of the material).
- If compressed air is present, blow out the components.

9.3 Changing diaphragm and reed valves

- Requirements
- Disconnect the drive from the mains and ensure that it is deenergized.
 - Allow the pump and the drive to cool.
 - Clean the pump and free the pump of hazardous materials.
 - Remove the hoses/pipes from the pneumatic pump inlet and outlet.
 - Remove the transport eyebolt from the pump if necessary.

With multi-headed pumps, parts of the various pump heads might become mixed up.

- Change the parts of the individual pump heads that are to be replaced one at a time.



Risk of explosion from formation of potentially explosive atmosphere

Leaky connections can result in dangerous potentially explosive atmospheres.

- Make certain that all elastomer parts are undamaged, clean and correctly installed.
- Check the pneumatic connections of the pump for leaks.
- Work with care during service work.
- Replace defective parts immediately.



Health hazard due to dangerous substances in the pump

Depending on the medium being transferred, caustic burns or poisoning is possible.

- Wear protective equipment if necessary, e.g., protective gloves, goggles.
- Clean the pump with suitable measures.



Risk of burns from hot pump parts

The pump head or motor may still be hot after operation of the pump.

- Allow the pump to cool after operation.



For two-headed pumps:

Servicing work should generally be performed on both heads at the same time.

Spare parts	Spare part*	Item designation**	Quantity
		Diaphragm	(17)
	O-ring	(10)	2 (per pump head)
	O-ring (only .13)	(11)	1 (per pump head)
	O-ring (only .13)	(12)	1 (per pump head)
	Reed valve, suction side	(8)	1 (per pump head)
	Reed valve, pressure side	(5)	1 (per pump head)
	Valve stopper, suction side	(9)	1 (per pump head)
	Valve stopper, pressure side	(4)	1 (per pump head)
	Slotted cheese-head screw	(2) and (7)	2 (per pump head)
	PTFE washer (for ST head only)	(16)	1 (per pump head)

Tab.20 *According to spare parts list, Chapter 11.1 Ersatzteile

** According to Individual parts of the pump head

Tool and material	Quan- tity	Tool/material
		1
	1	6 mm hex driver with torque indicator
	1	Screwdriver blade width 5.5 mm
	1	Open-end wrench 30 mm
	1	Adjustable face wrench for nuts with two holes*, pin diameter 4 mm, length approx. 160 mm (available as wrench for retainer plate as KNF accessory, see 11.2 Accessories).
	1	Felt-tip pen
	1	Hot air gun
	1	Adhesive (Delo ML5249) or comparable product

Tab.21 *According to accessories list, Chapter 11.2 Zubehör

- 1 Hexagon socket head cap screw
- 2 Slotted cap screw
- 3 Head cover
- 4 Valve stopper, pressure side
- 5 Reed valve, pressure side
- 6 Hexagon socket head cap screw
- 7 Slotted cap screw
- 8 Valve stopper, suction side
- 9 Reed valve, suction side
- 10 O-ring
- 11 O-ring (only .13)
- 12 O-ring (only .13)
- 13 Shim ring(s)
- 14 Conrod plate
- 15 Retainer plate
- 16 PTFE washer (ST head only)
- 17 Diaphragm
- 18 Intermediate plate

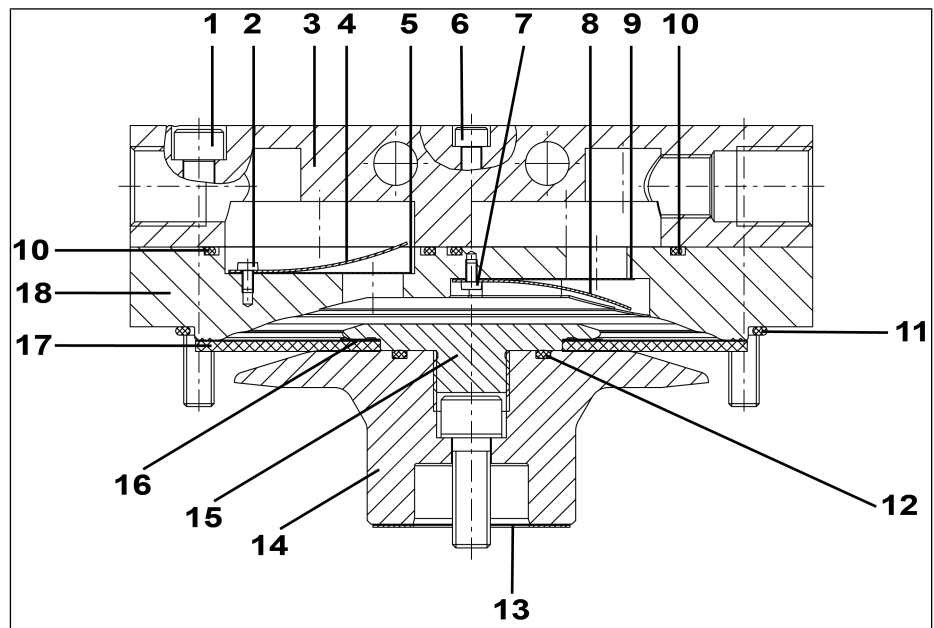

Fig.7 Components of the pump head

i The following item numbers refer to Individual parts of the pump head unless specified otherwise.

Removing the pump head

1. Accessing the fan blades:
Mark the motor fan cover with a continuous line made with a felt-tip pen (for later reassembly) and then loosen the fastening screws of the motor fan cover (see Chapter 5 *Product description and function*) and remove the cover.
2. For two-headed pumps only:
Remove the pneumatic connection between the pump heads; to do this, mark the union nuts according to Fig. 8 and loosen them. This helps to avoid incorrect assembly later.
3. Mark the head plate (3), intermediate plate (18) and the housing with one continuous felt-tip pen line for head 1 and with two continuous felt-tip pen lines for head 2. This helps to avoid incorrect assembly later.
4. Loosen the six hexagon socket head cap screws (1). Remove the head plate (3) and intermediate plate (18).

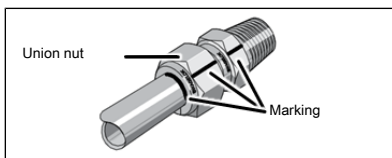

Fig.8 Marking of the union nuts



Risk of explosion from damage

If the housing cover is bent or if the paint is damaged, there is no risk of explosion.

→ Perform the work steps carefully and without the use of force.

5. For two-headed pumps:
Carry out step 3 for the second pump head.

Replacing the diaphragm

1. Heat the retainer plate (15) with a hot air gun (T=approx. 400 °C) for approx. 5 minutes to approx. 100 °C.



Risk of burns from hot parts

Burns may occur on skin contact with the hot retainer plate and countersunk screw or other heated pump parts.

→ Wear protective gloves.

→ Only loosen the retainer plate with face spanner wrench.

→ Only place the retainer plate and countersunk screw on a heat-resistant surface.

2. Removing the retainer plate (15):
Loosen the retainer plate from the conrod plate (14) with the wrench for retainer plate by turning counterclockwise and remove it.
3. For SP head only:
Remove the diaphragm (17).
4. For ST head only:
Remove the diaphragm (17) together with the PTFE washer (16).
5. Only .13:
Remove the O-ring (11) from the housing.
6. Only .13:
Remove the O-ring (12) from the conrod plate (14).
7. Check all parts for contamination and clean them if necessary (see 9.2 *Cleaning*).

i There may be glue residue on the external thread of the retainer plate as well as on the internal thread of the conrod plate. Remove this.

8. Turn the fan blade to move the connection rod with conrod plate (14) to the middle position.
9. For SP head only:
Fit the new diaphragm (17) on the conrod plate (14); make certain that the inner beads on the outer and inner circumference of the diaphragm are seated in the grooves of the housing and conrod plate.
10. For ST head only:
Fit the new diaphragm (17) together with the PTFE washer (16) on the conrod plate (14).

i When fitting the diaphragm, ensure that the blue PTFE coating on the diaphragm is facing upwards.

11. Only .13:
Insert the new O-ring (11) in the housing.
12. Only .13:
Insert the new O-ring (12) in the conrod plate (14).
13. Apply the adhesive around the threaded end of the retainer plate (15) and screw the retainer plate into the connection rod.

i While screwing in, turn the retainer plate back one turn to allow the adhesive to spread onto both thread flanks (retainer plate and conrod plate).

i For ST head only:
Ensure that the PTFE washer and the diaphragm are fully embedded in the ridge on the retainer plate. Also take care that the PTFE washer and the diaphragm do not slip while they are being screwed in and are lying flush one on top of the other.

i Attention: Note the use-by-date for the adhesive.
The adhesive may lose its effectiveness after the use-by-date has passed.

14. Then securely tighten the retainer plate (**15**) with the wrench for retainer plate (tightening torque: 20 Nm).

i Attention: Observe the hardening time for the adhesive before recommissioning the pump.

The hardening time for the adhesive is approx. 24 hours.

15. For two-headed pumps:
Perform steps 1 to 12 for the second pump head.

Changing reed valves

1. Loosen the two hexagon socket head cap screws (**6**).
2. Remove the head plate (**3**) from the intermediate plate (**18**).

i Carefully set down the head plate and intermediate plate so as not to damage their sealing edges.

3. Remove the two O-rings (**10**) from the intermediate plate (**18**).
4. Remove the valve stopper (**4**) and the reed valve on the pressure side (**5**) after loosening the screw (**2**).
5. On the pressure side, assemble with new reed valve together with the valve limiter (tightening torque for screw (**2**): 1.5 Nm).
6. After loosening the screw (**7**), remove valve stopper on the suction side (**8**) and the reed valve on the suction side (**9**) from the intermediate plate (**18**).
7. On the suction side, assemble the new reed valve together with the valve stopper (tightening torque for screw (**7**): 1.5 Nm).
8. For two-headed pumps:
Perform steps 1 to 4 for the second pump head.

Fitting the pump head

1. Insert the two new O-rings (**10**) in the intermediate plate (**18**).
2. Place the head plate (**3**) on the intermediate plate (**18**) according to the felt-tip pen marking.
3. Finger-tighten the hexagon socket head cap screws (**6**).
4. Place the pump head on the housing according to the felt-tip pen marking.
5. Screw in the hexagon socket head cap screws (**1**) one to two turns.
6. Tighten the two hexagon socket head cap screws (**6**) (tightening torque: 4 Nm).
7. Tighten the hexagon socket head cap screws (**1**) crosswise (tightening torque: 11 Nm).
8. Tighten the hexagon socket head cap screws (**1**) crosswise again until they are fully tightened (tightening torque: 11 Nm).
9. For two-headed pumps:
Perform steps 1 to 6 for the second pump head.

10. For two-headed pumps:
Mount the pneumatic connection between the pump heads. In doing so, retighten the union nuts slightly above the original position (as marked during disassembly, see Fig. 8).
11. Install the motor fan cover (see Chapter 5 *Product description and function*) according to the felt-tip pen marking.

i When fitting the motor fan cover, make sure that all of the screws are fitted again, the fan cover and the fan are undamaged, and the fan can rotate freely. To do this, perform a function test.

12. Function test
Perform a function test in a non-explosive atmosphere.
- Connect the suction and pressure sides to the pump.
 - Electrically connect the pump.
 - Test the functionality of the pump.
 - Disconnect the pump electrically and pneumatically again.
13. Pump integrated in application
- Connect the suction and pressure sides to the pump.
 - Electrically connect the pump.
 - Test the functionality of the pump.

i To ensure the required gas tightness of the pump following servicing, a leak test is to be performed.



Risk of explosion from leaks

→ Before recommissioning the pump, check the pump heads and pneumatic connections for leaks. Leaks may lead to a risk of explosion.



Risk of injury and poisoning from leaks

→ Before recommissioning the pump, check the pump heads and pneumatic connections for leaks. Leaks may lead to poisoning, chemical burns or similar injuries.

9.4 Checking and replacing sprocket on coupling

- Requirements
- Disconnect the motor from mains and ensure that it is voltage-free.
 - Allow the pump and the motor to cool.



Risk of burns from hot pump parts

The pump head or motor may still be hot after operation of the pump.

- Allow the pump to cool after operation.



Personal injury and/or property damage due to incorrect or improper transport of the motor

In the event of incorrect or improper transport, the motor can fall down, be damaged or injure persons.

- Use suitable auxiliary means if necessary (carrying strap, lifting gear, etc.).
- Where appropriate, wear suitable personal protective equipment (e.g., safety shoes, safety gloves).

Tool and material

Quantity	Tool/material
1	Feeler gage 3 mm
1	Test adapter for coupling (see Chapter 11.2 Accessories)
1	16mm open-end wrench with torque indicator

Tab.22

Spare parts

Spare part	Item designation	Quantity
Sprocket	(4)	1

Tab.23

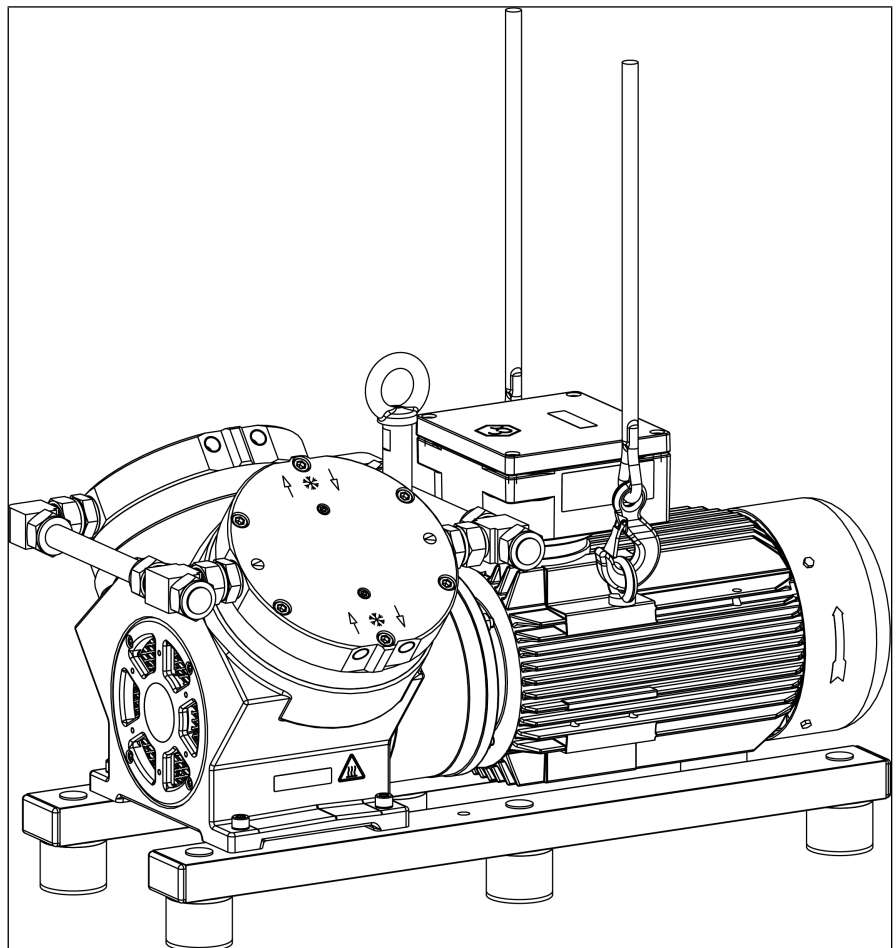

Fig.9 Lifting motor (depicted pump as an example)

- 1 Nut
- 2 Serrated washer
- 3 Motor
- 4 Sprocket
- 5 Motor-side coupling half
- 6 Pump-side coupling half
- 7 Compressor housing
- 8 Stud bolts
- 9 Motor fan cover
- 10 Fastening screw for motor fan cover

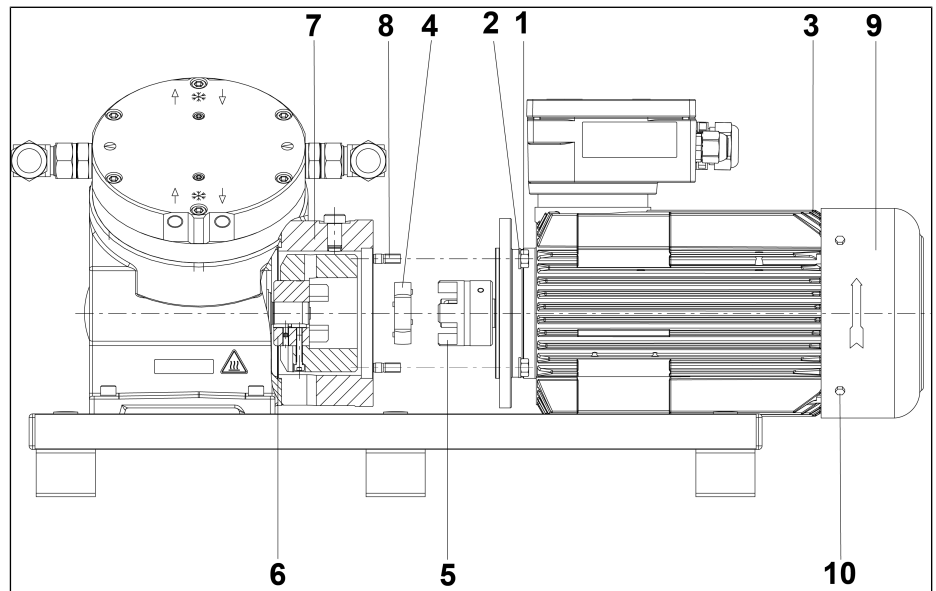

Fig.10 Replacing sprocket (depicted pump as an example)

Removing the motor

1. Attach the lifting gear (see figure for lifting motor) to the motor (3).
2. Loosen the nuts (1) that connect the motor (3) to the compressor housing (7).
3. Remove the ribbed disks (2).
4. Remove the motor (3) from the compressor housing (7).

Checking the sprocket

i Observe the intervals for the periodic inspection of the coupling play (see operating instructions for the coupling).

1. Place the sprocket (4) on the motor-side coupling half (5).
2. Place the test adapter for the coupling on the motor-side coupling half (5).
3. Use the feeler gage to check the coupling play (see operating instructions for the coupling).
4. Replace the sprocket (4) if there is too much coupling play (see operating instructions for the motor).
5. Define the intervals for the periodic inspection of the coupling play (see operating instructions for the motor).

Replacing the sprocket

1. Remove the worn sprocket (4) from the motor-side (5) or pump-side coupling half (6).
2. Push the new sprocket (4) onto the pump-side coupling half (6).

i The sprocket is symmetric and can be pushed on in both possible positions.

Installing the motor

1. Align the motor-side (5) and pump-side coupling halves (6) with one another.
2. Place the motor (3) on the compressor housing (7).

i Centering is performed using the four stud bolts (8) in the flange of the compressor housing (7) as well as the previously inserted sprocket.

3. Check whether the flange surface of the motor (3) and the flange surface of the compressor housing (7) lie properly on top of one another.
4. Push the four ribbed disks (2) onto the stud bolts (8).

i Make certain that the inner diameter of the ribbed disk (2) lies against the nut (1) and the outer diameter lies against the motor flange (3) (see Fig. 11).

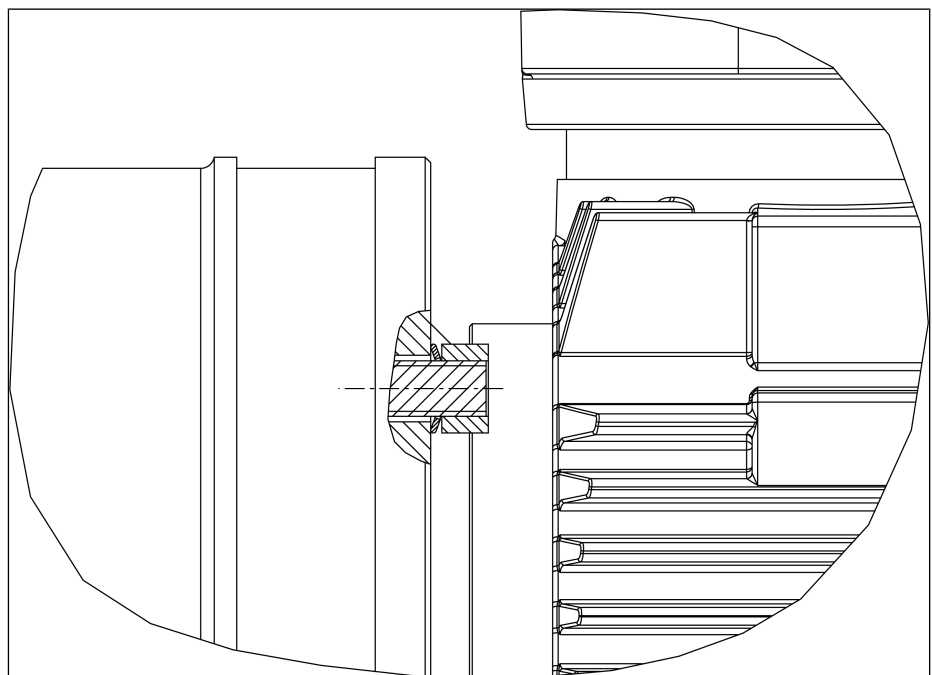

Fig.11 Alignment of the ribbed disk (2)

5. Turn the four nuts (1) on the stud bolts (8) and tighten them crosswise (tightening torque: 11 Nm).

Inspecting pumps

1. Mark the motor fan cover (9) with a continuous line made with a felt-tip pen.
2. Loosen the fastening screws (10) of the motor fan cover (9) and remove the motor fan cover (9).
3. Check the pump for smooth running by turning the fan.
4. Refit the motor fan cover (9) according to the marking.
5. Hand-tighten the fastening screws (10) again.

i When fitting the motor fan cover, make sure that all of the screws are fitted again, the fan cover and the fan are undamaged, and the fan can rotate freely. To do this, perform a function test.

6. Function test
Perform a function test in a non-explosive atmosphere.
 - Connect the suction and pressure sides to the pump.
 - Electrically connect the pump.
 - Test the functionality of the pump.
 - Disconnect the pump electrically and pneumatically again.
7. Pump integrated in application
 - Connect the suction and pressure sides to the pump.
 - Electrically connect the pump.
 - Test the functionality of the pump.

10 Troubleshooting



Danger: electric shock can be life-threatening.

- All work on the pump may only be performed by an authorized specialist.
- Before working on the pump: Disconnect the pump from the power supply.
- Check and ensure that no voltage is present.

- Allow the pump to cool before troubleshooting.
- Check the pump (see following tables).
- Also observe the operating instructions for the drive when troubleshooting.
- Also observe the operating instructions for the coupling when troubleshooting.

Pump not pumping	
Cause	Troubleshooting
Pump is not connected to the electrical mains.	→ Connect the pump to the electrical mains.
No voltage in the electrical mains.	→ Check the circuit breaker for the room and switch it on if necessary.
Pneumatic connections or lines are blocked.	→ Check the pneumatic connections and lines. → Remove the blockage.
External valve is closed or filter clogged.	→ Check external valves and filters.
Condensation has collected in the pump head.	→ Isolate the source of condensation from the pump. → Flush the pump with air at atmospheric pressure for a few minutes (if necessary for safety reasons: with an inert gas). → Install the pump at the highest location in the system.
Diaphragm or reed valves are worn.	→ Change the diaphragm and the reed valves (see Chapter 9 <i>Servicing</i>).

Tab.24

Flow rate, pressure or vacuum too low	
The pump does not reach the output stated in the technical data or data sheet.	
Cause	Troubleshooting
Condensation has collected in the pump head.	<ul style="list-style-type: none"> → Isolate the source of condensation from the pump. → Flush the pump with air at atmospheric pressure for a few minutes (if necessary for safety reasons: with an inert gas). → Install the pump at the highest location in the system.
There is overpressure on the pressure side and at the same time vacuum or pressure above atmospheric pressure on the suction side.	<ul style="list-style-type: none"> → Change the pneumatic conditions.
Pneumatic lines or connection parts have insufficient cross section or are throttled.	<ul style="list-style-type: none"> → Disconnect the pump from the system to determine the output values. → Correct any constriction (e.g. valve). → If necessary, install lines or a connector component with a larger cross section.
Leaks occur at pneumatic connections, lines or pump head.	<ul style="list-style-type: none"> → Eliminate the leaks.
Pneumatic connections or lines are partially or completely blocked.	<ul style="list-style-type: none"> → Check the pneumatic connections and lines. → Remove any parts and particles that are causing the blockage.
Head parts are soiled.	<ul style="list-style-type: none"> → Clean the head components.
Diaphragm or reed valves are worn.	<ul style="list-style-type: none"> → Change the diaphragm and the reed valves (see Chapter 9 <i>Servicing</i>).
Working diaphragm broken	<ul style="list-style-type: none"> → Stop the pump immediately.
Pump exhibiting changed running noises and vibrations.	<ul style="list-style-type: none"> → Stop the pump immediately. → Contact KNF Customer Service.

Tab.25

Pump exhibiting changed running noises and vibrations.	
Cause	Troubleshooting
Pump bearing worn or defective.	<ul style="list-style-type: none"> → Determine the cause. → Contact KNF Customer Service.
Drive worn or defective.	<ul style="list-style-type: none"> → See operating instructions for the drive.

Tab.26

Fault cannot be rectified

If you are unable to identify any of the specified causes, send the pump to KNF Customer Service (contact data: see www.knf.com).

1. Flush the pump with air for a few minutes (if necessary for safety reasons: with an inert gas) at atmospheric pressure in order to remove hazardous or aggressive gases from the pump head (see Chapter 9.2.1 *Flushing the pump*).
2. Clean the pump (see Chapter 9.2.2 *Cleaning the pump*).
3. Send the pump together with completed Health and Safety Clearance and Decontamination Form to KNF, stating the nature of the transferred medium.

11 Spare parts and accessories

i To order spare parts and accessories, please contact your KNF sales partner or KNF Customer Service (contact data: see www.knf.com).

11.1 Spare parts

Spare part set

A spare part set consists of:

Parts	Item number*	Quantity
Diaphragm	(17)	2
PTFE washer (ST head only)	(16)	2
Reed valves	(5), (9)	4
Valve limiter	(4), (8)	4
O-ring (D55 x 3,0)	(10)	4
Slotted cap screw	(2), (7)	4

Tab.27 *See Chapter 9.3 Changing diaphragm and reed valves

Spare parts set	Order number
N680_STE EX	333499
N680_SPE EX	333500

Tab.28

Spare part	Item number*	Order number
Sprocket for coupling	(4)	322343

Tab.29 *see 9.4 Checking and replacing sprocket on coupling

11.2 Accessories

Accessories	Order number
Water cooling connection	329236
Transport lug	311535
Wrench for retainer plate	128753
Test adapter for coupling	322339
Corrugated hose for pneumatic connection; Length 500 mm; G1/2"	333224
Corrugated hose, certified for pneumatic connection; Length 500 mm; G1/2"	333226

Tab.30

12 Returns

Preparing for return

1. Flush the pump with air for a few minutes (if necessary for safety reasons: with inert gas) at atmospheric pressure to free the pump head of dangerous or aggressive gases (see Chapter 9.2.1 *Flushing the pump*).

i Please contact your KNF sales partner if the pump cannot be flushed due to damage.

2. Remove the pump.
3. Clean the pump (see Chapter 9.2.2 *Cleaning the pump*).
4. Send the pump together with the completed Health and Safety Clearance and Decontamination Form to KNF, stating the nature of the transferred medium.
5. Pack the device securely to prevent further damage to the product. If necessary, request original packaging for a fee.

Returns

KNF shall undertake to repair the pump only under the condition that the customer presents a certificate regarding the medium that is pumped and the cleaning of the pump. In this case too, old devices can be returned. Please follow the instructions at [knf.com/repairs here](https://www.knf.com/repairs).

Contact your KNF sales partner directly if you require additional support for your return service.

13 Appendix

→ *13.1 Declaration of Conformity*

→ *13.2 Motor*

→ *13.3 Coupling*

13.1 Declaration of Conformity

For further information, see also

- Konformitätserklärung N680EX.pdf

EG / EU – Konformitätserklärung / EC / EU declaration of conformity

Hiermit erklärt der Hersteller:

Herewith the manufacturer:

KNF Neuberger GmbH, Alter Weg 3, D-79112 Freiburg

dass folgende Membranpumpen,

declares that the following diaphragm pumps:

(Seriennummer siehe Typenschild / Serial number see type label)

N680.1.2SP.9E EX

N680.1.2ST.9E EX

allen einschlägigen Bestimmungen folgender Richtlinien entspricht:

is in conformity with the following Directives:

Richtlinie 2006/42/EG Maschinen

Directive 2006/42/EC machinery

Richtlinie 2011/65/EU zur Beschränkung der Verwendung bestimmter gefährlicher Stoffe in Elektro- und Elektronikgeräten (Anhang II geändert durch die Delegierte Richtlinie (EU) 2015/863 der Kommission)

Directive 2011/65/EU on the restriction of the use of certain hazardous substances in electrical and electronic equipment (Annex II amended by Commission Delegated Directive (EU) 2015/863)

Richtlinie 2014/30/EU über elektromagnetische Verträglichkeit

Directive 2014/30/EU about the electromagnetic compatibility

Richtlinie 2009/125/EG zur Schaffung eines Rahmens für die Festlegung von Anforderungen an die umweltgerechte Gestaltung energieverbrauchsrelevanter Produkte und Verordnung (EU) 2019/1781 zur Festlegung von Ökodesign-Anforderungen an Elektromotoren und Drehzahlregelungen gemäß der Richtlinie 2009/125/EG des Europäischen Parlaments und des Rates.

Directive 2009/125/EC establishing a framework for the setting of ecodesign requirements for energy-related products and Regulation (EU) 2019/1781 laying down ecodesign requirements for electric motors and variable speed drives pursuant to Directive 2009/125/EC of the European Parliament and of the Council.

Folgende harmonisierte Normen wurden zugrunde gelegt:

The following harmonized standards have been applied:

EN 1012-2: 1996 + A1:2009

EN IEC 63000: 2018

Bevollmächtigter für die Zusammenstellung der technischen Unterlagen:

Authorised person to compile the relevant technical documentation:

R. Köpfer, Product Qualification, KNF Neuberger GmbH, Alter Weg 3, D-79112 Freiburg

Die Membranpumpen, fallen ebenso in den Anwendungsbereich der folgenden Richtlinie:

The diaphragm pumps falling in the scope of the following Directive as well:

Richtlinie 2014/34/EU für Geräte und Schutzsysteme zur bestimmungsgemäßen Verwendung in explosionsgefährdeten Bereichen

Directive 2014/34/EC relating to equipment and protective systems intended for use in potentially explosive atmospheres.

Die zugehörigen Konformitätserklärungen für den:

The corresponding conformity declaration for:

nichtelektrischen Pumpenteil: siehe Seite 2/4 dieser Erklärung

non-electrical part of the pump: see page 2/4 of this declaration

elektrischer Teil - Motor: siehe Seite 3-4/4 beiliegendes Dokument des Motorenherstellers

electrical part – motor: see page 3-4/4 enclosed document of motor supplier

Freiburg, 04.11.2021

Ort, Datum (TT.MM.JJJJ)
place, date (dd.mm.yyyy)

CO R&D



ppa. S. Schreiber

EU – Konformitätserklärung / EU declaration of conformity

Hiermit erklärt der Hersteller:

Herewith the manufacturer:

KNF Neuberger GmbH, Alter Weg 3, D-79112 Freiburg
dass folgende Membranpumpen – nichtelektrischer Pumpenteil,
declares that the following diaphragm pumps – non-electrical part:
(Seriennummer siehe Typenschild / Serial number see type label)

N680.1.2SP.9E EX

Kennzeichnung:
Marking:



II 2/2G Ex h IIB+H2 T3 Gb

N680.1.2ST.9E EX

Kennzeichnung:
Marking:



II 2/2G Ex h IIB T3 Gb

allen einschlägigen Bestimmungen folgenden Richtlinie entspricht:
is in conformity with the following Directive:

Richtlinie 2014/34/EU für Geräte und Schutzsysteme zur bestimmungsgemäßen Verwendung in explosionsgefährdeten Bereichen

Directive 2014/34/EC relating to equipment and protective systems intended for use in potentially explosive atmospheres.

Entsprechend Artikel 13 (1) b) ii) der RL2014/34/EU ist die technische Dokumentation bei der notifizierten Stelle Physikalisch-Technische Bundesanstalt PTB, Nr. 0102 hinterlegt.

According to article 13 (1) b) ii) of the directive 2014/34/EU, the technical documentation is deposited at the Physikalisch-Technische Bundesanstalt PTB, notified body no. 0102.

Folgende harmonisierte Normen wurden zugrunde gelegt:

The following harmonized standards have been applied:

EN ISO 80079-36:	2016
EN ISO 80079-37:	2016
EN 1127-1:	2019



EG / EU – Konformitätserklärung

HERFORDER ELEKTROMOTOREN-WERKE GmbH & Co. KG

D – 32051 Herford
D – 32008 Herford

Goebenstraße 106
Postfach 1852

Tel.: 05221 59040

info@HEW-HF.de

Die elektrischen Betriebsmittel:

Explosionsschutzte Drehstromasynchronmotoren (druckfeste Kapselung) mit Käfigläufer

Typ	Kennzeichnung Gas	Kennzeichnung Staub
DCEx 63	II 2G Ex db e IIC T4-T6 Gb oder II 2G Ex db IIC T4-T6 Gb	
DBEx 63	II 2G Ex db e IIB T4-T6 Gb oder II 2G Ex db IIB T4-T6 Gb	
DDEx 63	II 2G Ex db e IIC T4-T6 Gb oder II 2G Ex db IIC T4-T6 Gb	II 2D Ex tb IIIC T135°C - 85°C Db
DCEx 71 - 225	II 2G Ex db eb IIC T4-T6 Gb oder II 2G Ex db IIC T4-T6 Gb	
DBEx 71 - 225	II 2G Ex db eb IIB T4-T6 Gb oder II 2G Ex db IIB T4-T6 Gb	
DDEx 71 - 225	II 2G Ex db eb IIC T4-T6 Gb oder II 2G Ex db IIC T4-T6 Gb	II 2D Ex tb IIIC T135°C - 85°C Db
DCEx 250 und DCEx 280	II 2G Ex db eb IIC T4-T6 Gb oder II 2G Ex db IIC T4-T6 Gb	
DBEx 250 und DBEx 280	II 2G Ex db eb IIB T4-T6 Gb oder II 2G Ex db IIB T4-T6 Gb	
DDEx 250 und DDEx 280	II 2G Ex db eb IIC T4-T6 Gb oder II 2G Ex db IIC T4-T6 Gb	II 2D Ex tb IIIC T135°C - 85°C Db
DEx 315	II 2G Ex de IIC T4-T6 oder II 2G Ex d IIC T4-T6	

stimmen mit den Vorschriften folgender Europäischer Richtlinien überein:

- EMV-Richtlinie 2014/30/EU
- ATEX-Richtlinie 2014/34/EU
- RoHS-Richtlinie 2011/65/EU und (EU) 2015/863 (Änderung Anhang II)
- Elektromotorenverordnung 2019/1781/EU
- Maschinenrichtlinie 2006/42/EG

Die Übereinstimmung mit den Vorschriften dieser Richtlinien wird durch die Einhaltung nachstehender Normenreihen, mit allen relevanten Teilen nach aktuellem Datum, nachgewiesen:

- DIN EN 60034
- DIN EN 60079-0:2018, 60079-1:2014, 60079-7:2015 + A1:2018, 60079-31:2014

Es gelten folgende EG/EU-Baumusterprüfbescheinigung:

D_Ex 63: SIQ 16 ATEX 142 X (€0158 DEKRA DTC GmbH)
 D_Ex 71 – 225: BVS 14 ATEX E 114 X (€0158 DEKRA DTC GmbH)
 D_Ex 250: BVS 19 ATEX E 005 X (€0158 DEKRA DTC GmbH)
 D_Ex 280: BVS 19 ATEX E 006 X (€0158 DEKRA DTC GmbH)
 DEx 315: PTB 10 ATEX 1047 X (€0158 DEKRA DTC GmbH)

Das bezeichnete Produkt ist zum Einbau in eine andere Maschine bestimmt.

Die Inbetriebnahme ist solange untersagt, bis die Konformität des Endproduktes mit der Richtlinie 2006/42/EG festgestellt ist.

(M. Scheidt) Geschäftsleitung

Datum 30.06.2021

Die Sicherheitshinweise der Produktdokumentation sind zu beachten.

Diese Konformitätserklärung ist keine Zusicherung von Eigenschaften im Sinne der Produkthaftung.



EC / EU – declaration of conformity

HERFORDER ELEKTROMOTOREN-WERKE GmbH & Co. KG

D – 32051 Herford
D – 32008 Herford

Goebenstraße 106
post office box 1852

Tel.: 05221 59040

Info@HEW-HF.de

Electrical operating equipment:

Explosion-proof three phase asynchronous motors (flame-proof encapsulation) with squirrel cage

Typ	marking gas	marking dust
DCEx 63	II 2G Ex db e IIC T4-T6 Gb oder II 2G Ex db IIC T4-T6 Gb	
DBEx 63	II 2G Ex db e IIB T4-T6 Gb oder II 2G Ex db IIB T4-T6 Gb	
DDEx 63	II 2G Ex db e IIC T4-T6 Gb oder II 2G Ex db IIC T4-T6 Gb	II 2D Ex tb IIC T135°C - 85°C Db
DCEx 71 - 225	II 2G Ex db eb IIC T4-T6 Gb oder II 2G Ex db IIC T4-T6 Gb	
DBEx 71 - 225	II 2G Ex db eb IIB T4-T6 Gb oder II 2G Ex db IIB T4-T6 Gb	
DDEx 71 - 225	II 2G Ex db eb IIC T4-T6 Gb oder II 2G Ex db IIC T4-T6 Gb	II 2D Ex tb IIC T135°C - 85°C Db
DCEx 250 and DCEx 280	II 2G Ex db eb IIC T4-T6 Gb oder II 2G Ex db IIC T4-T6 Gb	
DBEx 250 and DBEx 280	II 2G Ex db eb IIB T4-T6 Gb oder II 2G Ex db IIB T4-T6 Gb	
DDEx 250 and DDEx 280	II 2G Ex db eb IIC T4-T6 Gb oder II 2G Ex db IIC T4-T6 Gb	II 2D Ex tb IIC T135°C - 85°C Db
DEx 315	II 2G Ex de IIC T4-T6 oder II 2G Ex d IIC T4-T6	

are conform to the regulations of the following European directives:

- EMV- directive 2014/30/EU
- ATEX- directive 2014/34/EU
- RoHS- directive 2011/65/EU and (Amendment Annex II (EU) 2015/863)
- Electric motor Regulation 2019/1781/EU
- Machinery directive 2006/42/EC

The compliance with the provisions of the directives is proved by the following series of standards with all relevant parts according to the current date:

- DIN EN 60034
- DIN EN 60079-0:2018, 60079-1:2014, 60079-7:2015 + A1:2018, 60079-31:2014

The following EG/EU-type examination certificate is valid:

D_Ex 63: SIQ 16 ATEX 142 X (€0158 DEKRA DTC GmbH
D_Ex 71 – 225: BVS 14 ATEX E 114 X (€0158 DEKRA DTC GmbH
D_Ex 250: BVS 19 ATEX E 005 X (€0158 DEKRA DTC GmbH
D_Ex 280: BVS 19 ATEX E 006 X (€0158 DEKRA DTC GmbH
DEx 315: PTB 10 ATEX 1047 X (€0158 DEKRA DTC GmbH

The designated product is to be seen as a component for installation into a machine or system.
Commissioning is prohibited until the conformity of the final product to the directive 2006/42/EC is established.

(M. Scheidt) Managing Director

date 30.06.2021

The safety instructions of the product documentation must be duly observed.
This declaration of conformity is no warranty of the characteristics in the sense of product liability.

13.2 Motor

For further information, see also

- Betriebsanleitung Motor.pdf
- Konformitätserklärung Motor.pdf



Operating manual

Electric motors **Size 63 - 225**
ATEX / IECEx

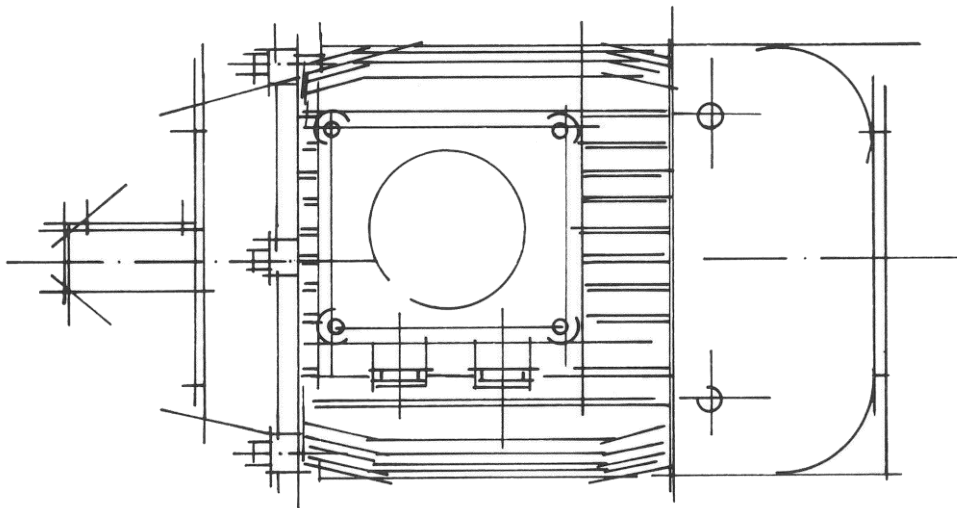

© Herforder Elektromotoren-Werke
GmbH & Co. KG
Goebenstr. 106
D-32051 Herford

Tel.: +49 (0) 5221 5904-0
Fax: +49 (0) 5221 5904-34

E-Mail: info@hew-hf.de
Internet: www.hew-hf.de

Release:

Created by:
Kothes!
Technische Kommunikation GmbH & Co. KG
www.kothes.de

This issue replaces all previous issues. All previous
issues are invalid. The date of issue (⇒ footer) is
authoritative.

1	General information	5
1.1	Information on this operating manual	5
1.2	Explanation of symbols	6
1.3	Limitation of liability	7
1.4	Copyright.....	8
1.5	Spare parts	8
1.6	Warranty conditions	8
1.7	Customer service	8
2	Safety	9
2.1	Responsibility of the user.....	9
2.2	Staff requirements	10
2.2.1	Qualifications.....	10
2.2.2	Unauthorised parties	12
2.2.3	Training.....	12
2.3	Proper use	12
2.4	Personal safety equipment and clothing.....	13
2.5	Special hazards	14
2.6	Safety devices.....	17
2.7	Securing the machine to prevent it from being switched back on	17
2.8	How to act in case of hazards and accidents	18
2.9	Environmental protection	19
3	Technical data	20
3.1	Operating conditions	20
3.2	Type plate	20
3.3	Explosion protection marking.....	21
4	Construction and function	23
4.1	Overview of sizes 63 to 132.....	23
4.2	Overview of sizes 160 to 225.....	24
4.3	Connection, motor protection.....	25
4.4	Obligations and conditions.....	25
4.5	Operation on the frequency converter	26
5	Transportation, packaging and storage	27
5.1	Delivery inspection.....	28
5.2	Transportation.....	29
5.3	Packaging	30
5.4	Storage	31



Table of contents

- 6 Installation and commissioning32**
 - 6.1 Safety32
 - 6.2 Installation34
 - 6.2.1 Ventilation at the location for use34
 - 6.2.2 Types of construction as per EN 60034-734
 - 6.2.3 Erecting the machine37
 - 6.2.4 Installation.....37
 - 6.3 Connecting to the energy supply38
 - 6.3.1 Screwed cable gland38
 - 6.3.2 Voltage and circuit39
 - 6.3.3 Checking the insulation resistance40
 - 6.4 Commissioning.....40
- 7 Operations42**
 - 7.1 General information.....42
 - 7.2 Shutting down in an emergency.....42
- 8 Faults43**
 - 8.1 Safety43
 - 8.2 Fault table45
 - 8.3 Commissioning after remedied fault47
- 9 Maintenance.....48**
 - 9.1 Safety48
 - 9.2 Cleaning50
 - 9.3 Maintenance schedule50
 - 9.4 Tightening torque values for screws52
 - 9.4.1 Tightening torque values for screws for electrical connections52
 - 9.4.2 Screw connections, property class 8.8 and A4-7053
 - 9.4.3 Screw connections of property class 5.653
 - 9.5 Measures on completion of maintenance54
- 10 Removal.....55**
 - 10.1 Safety55
 - 10.2 Removal56
 - 10.3 Disposal57

1 General information

1.1 Information on this operating manual

This operating manual makes it possible to handle the machine safely and efficiently.

The manual is a component of the machine and must be kept in the direct vicinity of the plant and be accessible to staff at all times. Staff must have carefully read and understood this manual before starting all work. Adherence to all the specified safety instructions and instructions for actions in this operating manual is a fundamental requirement for working safely.

The local regulations for the prevention of accidents and the general safety regulations for the location in which the machine is used also apply.

The illustrations in this operating manual are for purposes of general understanding and may differ from the actual machine version.

General information

1.2 Explanation of symbols

Safety instructions

The safety instructions in this manual are indicated by symbols. The safety instructions are introduced by signal words which express the extent of the risk.

It is imperative to adhere to safety instructions and act with caution in order to prevent accidents, personal injury and material damage.



DANGER!

... indicates an immediately dangerous situation which will lead to death or serious injuries if not avoided.



WARNING!

... indicates a possibly dangerous situation which may lead to death or serious injuries if not avoided.



CAUTION!

... indicates a possibly dangerous situation which may lead to minor or light injuries if not avoided.



CAUTION!

... indicates a possibly dangerous situation which may lead to material damage if not avoided.

Tips and recommendations



NOTE!

... draws attention to tips and recommendation and information for efficient, fault-free operation.

Special safety instructions

The following symbols are used in safety instructions in order to point out particular hazards.



... indicates risks from electrical current. Failure to observe the safety instructions will result in the risk of serious or fatal injury.

**EXPLOSION PROTECTION!**

... indicates content and instructions in this operating manual which apply when using this machine in potentially explosive areas as per the ATEX directive. Failure to observe this content and these instructions can lead to a loss of explosion protection.

1.3 Limitation of liability

All the information and instructions in this manual have been compiled in line with the valid standards and regulations, state-of-the-art technology and our many years of experience and know-how.

The manufacturer shall not be liable for damages caused by:

- Failure to observe the manual
- Improper use
- Employment of unqualified staff
- Arbitrary modifications
- Technical changes
- Use of non-approved spare parts

In case of special versions, the utilisation of additional order options or due to new technical changes, the actual scope of delivery may differ from the explanations described here and the illustrations.

The obligations agreed in the delivery contract, the General terms and Conditions and the Terms and Conditions of Delivery of the manufacturer, and the legal regulations valid at the point of completion of the contract apply.

We reserve the right to make technical changes within the scope of further development and improvement of the performance characteristics.

General information

1.4 Copyright

This operating manual is protected by copyright and for internal use only.

The manual must not be made available to third parties, reproduced in any way (including excerpts), its content must not be utilised and/or communicated without the written approval of the manufacturer, except for internal purposes.

Failure to comply will render the offender liable for damages. We reserve the right to further claims.

1.5 Spare parts

Explosion protection



EXPLOSION PROTECTION!

The use of incorrect or faulty spare parts can use to explosions in the potentially explosive area.

Therefore:

- Only use the manufacturer's original spare parts or spare parts expressly approved by the manufacturer.
- Always contact the manufacturer in case of any uncertainty.

Failure to adhere to these instructions will lead to a loss of the explosion protection.

Purchase spare parts from authorised dealers or directly from the manufacturer. See page 2 for the address.

The spare parts list can be found on pages 23-24.

1.6 Warranty conditions

The warranty conditions are included in the manufacturer's General Terms and Conditions.

1.7 Customer service

Our customer service department is available to provide technical information. See page 2 for contact details.

Furthermore our staff are always interested in receiving new information and hearing of new experiences gained from the use of our products which can be used to improve our products.

2 Safety

This section provides you with an overview of all important aspects of safety required for providing staff with optimum protection as well as safe, fault-free operation.

Failure to observe the instructions and safety instructions for actions in this operating manual can cause considerable risks.

2.1 Responsibility of the user

The machine is used in the commercial field. The user of the machine is therefore subject to the legal obligations for occupational safety.

In addition to the safety instructions in this manual, the regulations for safety, accident prevention and environmental protection which apply at the location for use of the machine must also be observed. The following in particular applies:

- The user must fully acquaint himself with the valid occupational safety regulations and, in addition, carry out a risk assessment to determine the hazards which result from the particular working conditions at the location in which the machine is used. The results must be implemented as a set of operating instructions for operation of the machine.
- The user must carry out checks during the entire period of its use to determine whether the operating instructions drawn up are in line with the current regulations and adjust them as necessary.
- The user must clearly set out the responsibilities for installation, operation, maintenance and cleaning.
- The user must make sure that all staff involved with work on the machine have read and understood the manual. Furthermore, staff must be provided with regular training and information on the following points:
 - Fire and explosion hazards at the machine's location for use and the immediate vicinity.
 - Local fire and explosion protection measures.
 - Location and function of protective equipment.
 - The necessity of a ban on smoking.
 - The necessity of avoiding open fire.
 - Procedure for cleaning and maintenance work and repairs, including the tools, aids and cleaning agents to be used.
 - The necessity of wearing personal safety equipment and clothing which is suitable for the potentially explosive environment.
- The user must adhere to the further obligations of Directive 99/92/EC for the improvement of health and safety measures

Safety

and the safety of employees who may be at risk from a potentially explosive atmosphere. This includes adherence to further organisational measures, such as:

- marking potentially explosive areas.
 - drawing up an explosion protection document for each zone.
 - denying unauthorised parties access.
 - putting up clear signs indicating all restraints.
 - introduction of a permit procedure for carrying out dangerous work.
- The user must provide staff with the required safety clothing and equipment.

The user is also responsible for ensuring that the machine is kept in technically perfect condition. The following applies:

- The user must make sure that the maintenance intervals described in the operating manual are adhered to. Reduce the intervals accordingly in case of above average strain.
- The user must have all the safety devices checked regularly to make sure they are complete and fully functional.

Loss of explosion protection



EXPLOSION PROTECTION!

On machines which are designed to be installed in plants for operation in potentially explosive areas, as defined by Directive 2014/34/EU, the user must make sure that the directive is adhered to for the entire plant.

Failure to comply will lead to a loss of the explosion protection.

2.2 Staff requirements

2.2.1 Qualifications



WARNING!

Risk of injuries in case of insufficiently qualified staff.

Improper use can cause considerable personal injury and material damage.

Therefore:

- Have all tasks performed by staff with the appropriate qualifications only.

The following levels of qualification are named in the operating manual for various ranges of tasks.

■ Trained person

has been informed of the tasks with which he has been entrusted and the possible risks in case of incorrect behaviour in training measures provided by the user.

■ Specialist staff

are capable of carrying out the work with which they have been entrusted and recognising the potential risks independently because of their specialist qualifications, knowledge and experience, and knowledge of the valid regulations.

■ Qualified electrician

is capable of carrying out the work on electrical equipment and recognising and preventing the potential risks independently because of their specialist qualifications, knowledge and experience, and knowledge of the valid standards and regulations.

The qualified electrician is qualified to work in the specific area in which he works and is familiar with the relevant standards and regulations.

■ Qualified specialist for the potentially explosive area

is capable of carrying out the work on plants or components in the potentially explosive area and recognising the potential risks independently because of their specialist qualifications, knowledge and experience, and knowledge of the valid standards and regulations.

The qualified specialist has knowledge of the various ignition protection types, installation procedures and area classifications in potentially explosive spaces, and certification for the purported experience and knowledge.

The person is familiar with the relevant rules and regulations for the work and explosion protection, in particular but not exclusively, ATEX product directive 2014/34/EU and the pertaining EN 60079 standard as well as the IECEx standard IEC 60079.

Staff should be made up exclusively of people who can be expected to carry out their work reliably. People whose reactions are influenced, for instance, by drugs, alcohol or medication, must not be allowed.

- When selecting staff adhere to the valid local regulations relating to age and profession.

Safety

2.2.2 Unauthorised parties



WARNING!

Danger for unauthorised parties.

Unauthorised persons who do not meet with the requirements described here, are not familiar with the hazards in the working area.

Therefore:

- Keep unauthorised persons away from the working area.
- In case of doubt, approach these persons and instruct them to leave the working area.
- Stop work until any unauthorised parties have left the working area.

2.2.3 Training

Staff must be provided with regular training by the user. Training must be logged to keep better track.

Date	Name	Type of training	Training provided by	Signature

Fig. 1

2.3 Proper use

The machine has been engineered and designed exclusively for the proper use described in this documentation.

The machine is only intended for use as a drive unit in low voltage industrial systems.

Proper use also includes adherence with all the stipulations of this manual.

Any other type of use, or use of the machine going beyond this use is considered improper use and can cause dangerous situations.

**WARNING!****Danger from improper use.**

Improper use of the machine can cause dangerous situations.

Take particular care not to use the machine as follows:

- Operation beyond the original designated application.
- Operation of machines in potentially explosive areas which do not have explosion protection markings and are thus not suitable for use in a potentially explosive atmosphere (⇒ Chapter "Explosion protection marking").

Claims of any kind for damages caused by improper use are null and void.

The user carries sole liability for any damages in case of improper use.

2.4 Personal safety equipment and clothing

Whilst work is being carried out, personal safety equipment and clothing must be worn in order to minimise health hazards.

- Always the safety clothing and equipment required for the respective task whilst working.
- Follow the instructions in the working area on personal safety equipment and clothing.

To be worn for all work



Occupational safety clothing

is close-fitting working clothing with a low tear strength, close-fitting sleeves and no protruding parts. It serves primarily as protection from entanglement in moving machine parts.

Do not wear rings, chains or other jewellery.



Safety shoes

to protect from heavy falling parts and from slipping on slippery surfaces.

Safety

To be worn for special tasks

When carrying out special tasks, special safety equipment and clothing is required. Reference is made to this in the individual chapters of this manual. These special items of safety clothing and equipment are explained in the following:



Light breathing mask

to protect from harmful dust.

2.5 Special hazards

The following section points out residual risks which have been determined by a risk analysis.

- Adhere to the safety instructions listed here and the warnings in other chapters in order to reduce health hazards and prevent dangerous situations.

Explosion protection



EXPLOSION PROTECTION!

The introduction of ignition sources such as sparks, open flames and hot surfaces can cause explosions in the potentially explosive area. Therefore, when carrying out all work on the machine in the potentially explosive area:

- Do not start any work without a written permit.
- Only carry out work to the exclusion of a potentially explosive atmosphere.
- Only use tools which are approved for use in the potentially explosive area.

Failure to adhere to these instructions will lead to a loss of the explosion protection.

Electrical current**DANGER!****Danger to life from electrical current.**

There is an immediate risk of fatal injury in case of contact with live parts. Damage to the insulation or individual components can mean danger to life.

Therefore:

- In case of damage to the insulation, switch off the power supply immediately and have repairs carried out.
- Have work on the electrical equipment carried out by qualified electricians only.
- When any work is carried out on the electrical equipment, disconnect it from the power and make sure it is free of voltage.
- Before carrying out maintenance, cleaning and repair work, switch off the power supply and secure it to prevent it from being switched back on.
- Do not jumper or disable any fuses or circuit breakers. When replacing fuses or circuit breakers make sure to adhere to the correct ampere rating.
- Keep moisture away from live parts. It can lead to a short circuit.

Moving parts**WARNING!****Risk of fatal injury from moving parts.**

Rotating parts and/or parts which move linearly can cause serious injuries.

Therefore:

- Do not reach into moving parts or handle moving parts during operation.
- Do not open covers during operation.
- Adhere to the follow-up time:
Before opening covers make sure that none of the parts are still moving.
- In the danger area wear close-fitting protective clothing.

Safety**Hot surfaces****CAUTION!****Risk of burns from hot surfaces.**

Contact with hot parts can cause burns.

Therefore:

- When working in the vicinity of hot parts always wear protective clothing and protective gloves.
- Before carrying out any work make sure that all components have cooled to ambient temperature.

Soiling and objects lying around**CAUTION!****Risk of stumbling due to soiling and objects left lying around.**

Soiling and objects left lying around are sources of slipping and stumbling and can cause considerable injuries.

Therefore:

- Always keep the working area clean.
- Remove any objects which are no longer required.
- Mark any possible stumbling hazards with yellow and black marker tape.

Sharp edges and corners**CAUTION!****Risk of injuries from edges and corners.**

Sharp edges and corners can cause grazes and cuts on the skin.

Therefore:

- Proceed with caution when working in the vicinity of sharp edges and corners.
- If in doubt wear protective gloves.

2.6 Safety devices

Integration into an emergency stop concept required

The machine is for use within a plant. It does not have its own control unit and does not have an independent emergency stop function.

Before the machine is put into operation install the emergency stop devices for the machine and integrate it into the plant control unit's safety chain.

Connect the emergency stop devices so that there is no chance that dangerous situations for people and objects of material value cannot arise if the energy supply is broken or the energy supply is activated after being broken.

The emergency stop devices must be freely accessible at all times.

2.7 Securing the machine to prevent it from being switched back on



DANGER! **Risk of death from switching on without authorisation!**

When working in the danger area there is a risk that the energy supply will be switched on without authorisation. This puts the life of people in the danger area at risk.

Therefore:

- Adhere to the instructions on securing the machine to prevent it from being switched on in the chapters of this manual.
- Always adhere to the procedure described below to secure the machine to prevent it from being switched back on.

Safety

Switch secured with a padlock
 on: at h.
DO NOT SWITCH ON
 The padlock must only be removed
 by:
 once you have made sure that there is
 nobody in the danger area.

Fig. 2

Switched off
 on: at h.
DO NOT SWITCH ON
 Only to be switched on
 by:
 once you have made sure that there is
 nobody in the danger area.

Fig. 3

Securing the machine to prevent it from being switched back on:

1. Switch off the energy supply.
2. If possible, secure the switch with a padlock and attach a clearly visible sign according to Fig. 2 to the switch.
3. Have the key kept safely by the member of staff named on the sign.
4. If it is impossible to secure a switch with a padlock, erect a sign according to Fig. 3.
5. Once all work has been carried out, make sure that nobody is in the danger area.
6. Make sure that all safety devices and mechanisms are installed and fully functional.
7. Do not remove the sign until you have done so.

2.8 How to act in case of hazards and accidents

Preventive measures

- Always be prepared for accidents or fires.
- Keep first aid facilities (first aid box, blankets etc.) and fire extinguishers accessible at all times.
- Familiarise staff with accident report, first aid and rescue facilities.
- Keep access routes for emergency vehicles clear.

Measures in case of accidents

- Trigger an emergency stop immediately.
- Instigate first aid measures.
- Remove any people from the danger zone.
- Inform the responsible party at the location.
- Notify emergency services.
- Clear access routes for emergency vehicles.

2.9 Environmental protection

**CAUTION!****Risk of environmental damage in case of incorrect handling.**

Incorrect handling of environmentally hazardous substances, in particular incorrect disposal, can cause considerable damage to the environment.

Therefore:

- Always adhere to the instructions below.
- If environmentally hazardous substances are accidentally released into the environment, take suitable measures immediately. In case of doubt inform the responsible local authority of the damage.

The following environmentally hazardous substances are used:

Lubricants

Lubricants such as grease and oils contain toxic substances. They must not be released into the environment. They must be disposed of by a specialist disposal company.

**NOTE!**

The motors comply with EC Directive 2011/65/EU for the limitation of the use of certain hazardous substances in electrical and electronic devices.

Technical data

3 Technical data



NOTE!

The necessary technical data can be found on the respective type plates. This information is authoritative.

Further technical data can be taken from the catalogue.

3.1 Operating conditions

Environment

Specification	Value	Unit
Temperature range (standard)	-20...+40	°C
Temperature range (optional)	-50...+85	°C
Maximum installation height above sea level	1000	m

The ambient temperature range is only indicated on the type plate if it deviates from the standard.

3.2 Type plate

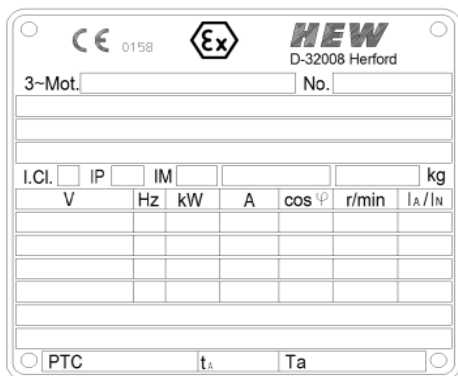

Fig.4: Example of a type plate

The type plate is situated on the motor housing and the information it contains includes:

- Explosion protection symbol
- Manufacturer/year of manufacture
- CE symbol
- ID of notified body
- Certificate number
- Motor identification (type), motor number (serial number)
- Weight
- Performance data
- Ambient temperatures deviating from the standard temperatures of – 20°C to + 40°C specified in the standard



NOTE!

The information on the type plate may vary depending on the type of motor.

3.3 Explosion protection marking

EXPLOSION PROTECTION!

acc. to ATEX directive 2014/34/EU

standard EN 60079 or IECEx / standard IEC 60079

Marking acc. to ATEX – size 63

II 2G Ex db IIC T4 – T6 Gb or Ex db e IIC T4 – T6 Gb

Oder II 2G Ex db IIC T4 – T6 Gb or Ex db eb IIC T4 – T6 Gb



II 2G Ex db IIB T4 – T6 Gb or Ex db e IIB T4 – T6 Gb

Oder II 2G Ex db IIB T4 – T6 Gb or Ex db eb IIB T4 – T6 Gb



II 2D Ex tb IIIC T 135 – 85°C Db



II 2D Ex tb IIIB T 135 – 85°C Db

Marking acc. to IECEx – size 63

 Ex db IIC T4 – T6 Gb or Ex db e IIC T4 – T6 Gb
 or Ex db IIC T4 – T6 Gb or Ex db eb IIC T4 – T6 Gb

 Ex db IIB T4 – T6 Gb or Ex db e IIB T4 – T6 Gb
 or Ex db IIB T4 – T6 Gb or Ex db eb IIB T4 – T6 Gb

Ex tb IIIC T 135 – 85°C Db

Ex tb IIIB T 135 – 85°C Db

Marking acc. to ATEX – sizes 71 -225

II 2G Ex db IIC T1 – T6 Gb or Ex db eb IIC T1 – T6 Gb

or II 2G Ex d IIC T1 – T6 Gb or Ex de IIC T1 – T6 Gb



II 2G Ex db IIB T1 – T6 Gb or Ex db eb IIB T1 – T6 Gb

or II 2G Ex d IIB T1 – T6 Gb or Ex de IIB T1 – T6 Gb



II 2D Ex tb IIIC T 200 – 85°C Db

Marking acc. to IECEx – sizes 71 -225

 Ex db IIC T1 – T6 Gb or Ex db eb IIC T1 – T6 Gb
 or Ex d IIC T1 – T6 Gb or Ex de IIC T1 – T6 Gb

 Ex db IIB T1 – T6 Gb or Ex db eb IIB T1 – T6 Gb
 or Ex d IIB T1 – T6 Gb or Ex de IIB T1 – T6 Gb

Ex tb IIIC T 200 – 85°C Db

Technical data

Section	Designation	Significance
	Explosion protection symbol	Marking for protection from explosions
II	Device group	Device group II. The motor can be used in potentially explosive areas except in mining.
2	Category	For application in Zone 1 and Zone 21
G D	Explosive atmosphere	... cause by gas. ... cause by dust.
Ex	Standard	Standard on explosion protection
d / db e / eb tb	Ignition protection type	Pressurised enclosure. Increased safety. Protection by housing
IIC IIB IIIC IIIB	Explosion group Dust group	Maximum experimental safe gap (MESG) Type and shape
T1 – T6	Temperature class	maximum surface temperature present T1 (450 °C) – T6 (85 °C)
Gb Db	EPL	equipment protection level



NOTE!

There may be further signs on the machine with various pieces of information.

4 Construction and function

4.1 Overview of sizes 63 to 132

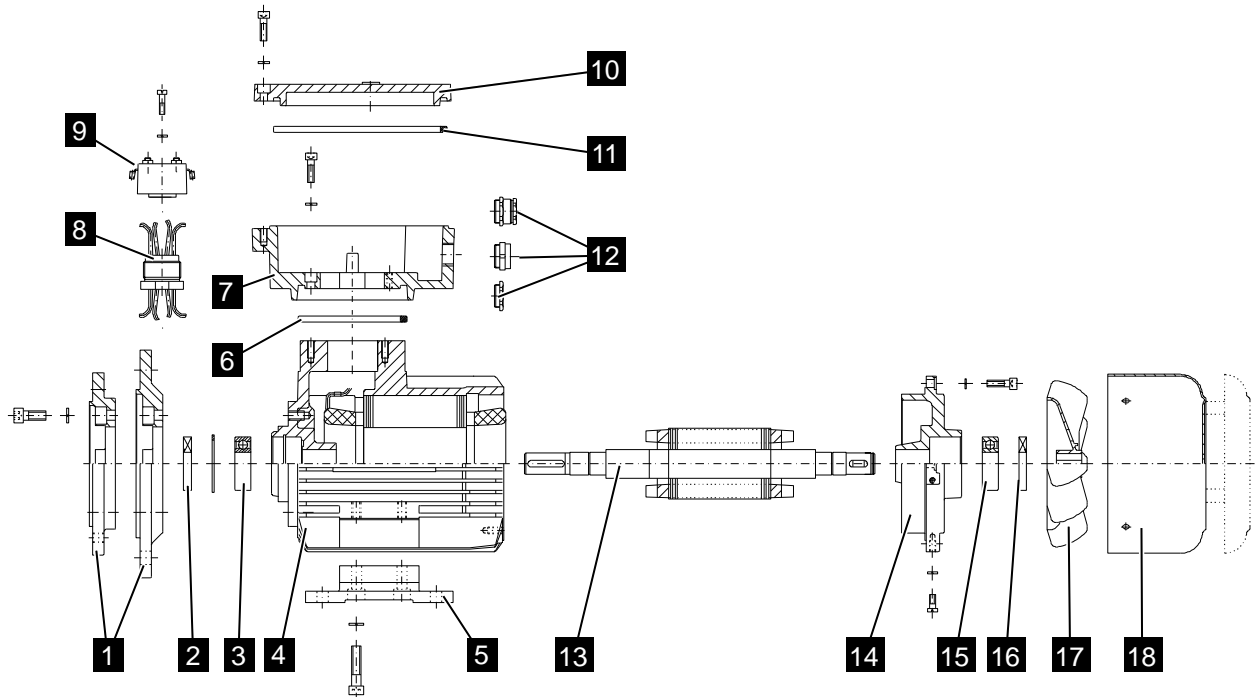

Fig. 5: Overview of sizes 63 to 132

- | | | | |
|---|----------------------------|----|---|
| 1 | Flange rings | 10 | Terminal box cover |
| 2 | Sealing rings DS*1 | 11 | Terminal box cover seal |
| 3 | Rolling bearings DS*1 | 12 | Screwed cable gland |
| 4 | Stator housing, complete | 13 | Rotor shaft, complete |
| 5 | Motor foot | 14 | Bearing cover NS*2 |
| 6 | Terminal box seal | 15 | Rolling bearings NS*2 |
| 7 | Lower terminal box section | 16 | Sealing ring NS*2 |
| 8 | Cable bushing | 17 | Fan blade |
| 9 | Terminal board | 18 | Ventilation hood (with optional safety cover) |

*1 DS = Drive side

*2 NS = Nondrive side

! For sizes 63 and 71 the terminal box is casted

Construction and function

4.2 Overview of sizes 160 to 225

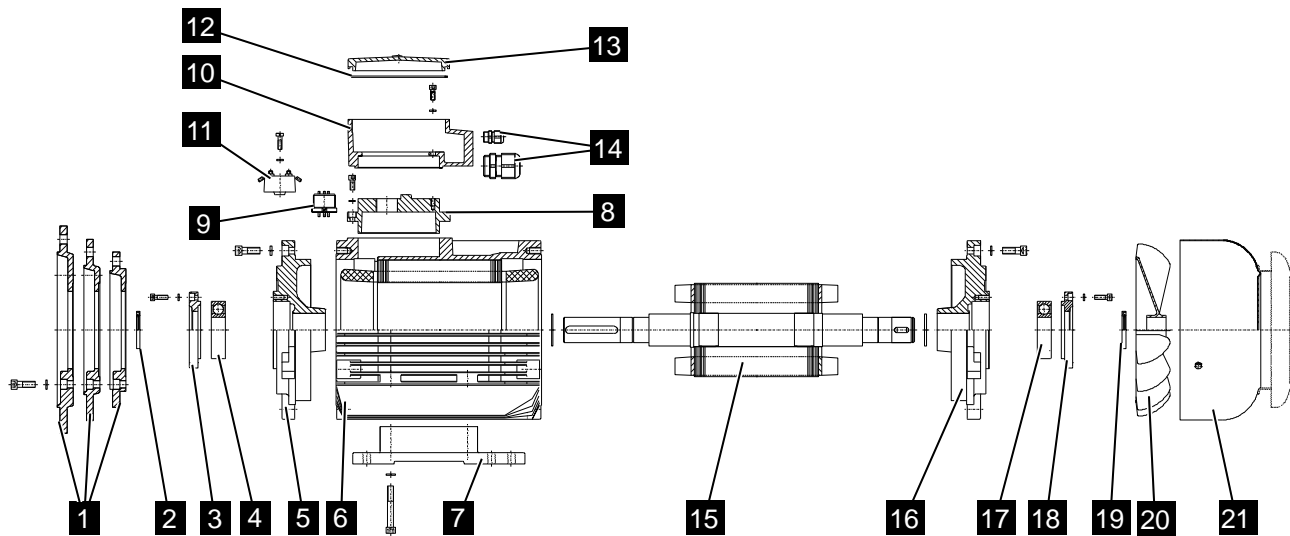

Fig. 6: Overview of sizes 160 to 225

- | | | | |
|----|-----------------------------------|----|---|
| 1 | Flange rings | 12 | Terminal box cover seal |
| 2 | Sealing rings DS* ¹ | 13 | Terminal box cover |
| 3 | Cover plate DS* ¹ | 14 | Screwed cable glands |
| 4 | Rolling bearings DS* ¹ | 15 | Rotor shaft, complete |
| 5 | Base flange | 16 | Bearing cover NS* ² |
| 6 | Stator housing, complete | 17 | Rolling bearings NS* ² |
| 7 | Motor foot | 18 | Cover plate NS* ² |
| 8 | Terminal box adapter | 19 | Sealing ring NS* ² |
| 9 | Cable bushing | 20 | Fan blade |
| 10 | Lower terminal box section | 21 | Ventilation hood (with optional safety cover) |
| 11 | Terminal board | | |

*¹ DS = Drive side

*² NS = Nondrive side

4.3 Connection, motor protection

Before connecting the explosion protected motor, check the following:

- do the ratings on the type plate match the mains voltage and frequency?
- does the explosion protection match the environment in which the motor is operated (gas group, temperature class)?

The electrical connections are established using the terminal box. The connection diagram (wiring diagram) is inside the terminal box.

Optionally the motors can be supplied with a motor cable instead of with a terminal box (⇒ catalogue).

If a standstill heating is present, the electrical controller has to ensure that the motor voltage and the heating voltage cannot be applied simultaneously.

The motor protection can be implemented with a motor protection switch or a thermal sensor (PTC, PTO, PT100).

For self-ventilated, single-speed motors in S1 mains operation with low-load and infrequent starts not causing any significant heating, a motor protection switch is a sufficient measure to comply with explosion protection requirements (temperature class).

Exclusive protection by temperature monitoring with thermal sensor for all modes other than S1 is only permitted in connection with a **certified** triggering device. These triggering devices must have been certified and marked by a notified body according to directive 2014/34/EU (IECEx). The devices must be included in the regular monitoring by the operator.

4.4 Obligations and conditions

Some gap lengths of the spark-proof gap of this equipment are greater, and some gap widths of the spark-proof gap are smaller than required in Table 3 of EN/IEC 60079-1:2014. For information regarding the dimensions, please contact the manufacturer.

To connect the pressure proof encapsulation, use screws with a yield point of at least 640 N/mm².

Motors requiring direct temperature monitoring have to be monitored with a separately certified triggering device (see 4.3).

Make sure when operating a 3-phase motor with an external fan that the motor can only be run while the external fan is running. The external fan motor must comply with EPL Gb or Db.

Make sure not to exceed the permissible temperatures for the used components.

Only metal fan blades may be used if the temperature on the shaft journal in the fan blade area is $\geq 95^{\circ}\text{C}$ during rated operation.

The manufacturer specifies the electrical parameters, the temperature class and the ambient temperature range of the respective version after a routine test.

Construction and function

4.5 Operation on the frequency converter

The motors of EX versions “pressure-proof encapsulation” Ex d(e) and “protection by housing” Ex t are approved for inverter operation. For approved versions, the possible frequency range must be obtained from the EU prototype test certificate.

The chart and the table below show and explain the most common curves for FI operation. The permissible torque at 50 Hz depends on the size, the number of poles and the performance; refer to the HEW catalogue “Explosion protected electric motors” (Part 20).

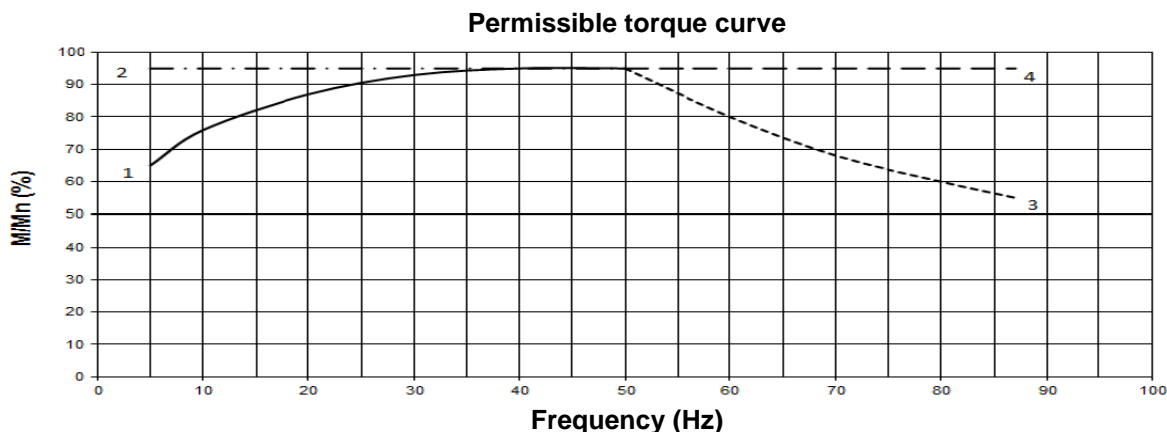

Characteristic curve	Frequency	Motor version	Motor voltage / circuit	Inverter	Ventilation	Torque curve in frequency range acc. to Catalogue Part 20
1	5 - 50 Hz	230/400 V 400/690V	400 V Y 400 V Δ	U/f=constant U/f=constant	internal fan	reduced
2	5 - 50 Hz	230/400 V 400/690V	400 V Y 400V Δ	U/f=constant U/f=constant	external ventilation	constant
3	50 - 87Hz	230/400 V 400/690V	400 V Y 400V Δ	U=constant U=constant	internal fan	drops with 1/f Field weakening operation
4	50 - 87Hz	230/400 V	230V Δ	U/f=constant	internal fan	constant 87 Hz curve

When the frequency range is specified in the order, the motors come with an additional plate indicating the FI operation data given on the right:
(Example: DCEx 112 M/4 K – 400 V Δ 50 Hz 4.0 kW)

DCEx 112 M/4 K / Motor number
40 V 5 Hz 0.24 kW Tperm.= 16 Nm
400 V 50 Hz 4.0 kW Tperm.= 27 Nm
400 V 87 Hz 4.0 kW Tperm.= 16 Nm

Sections 4.3 and 4.4 describe the motor protection for frequency inverter operation.

Use shielded cables to prevent electromagnetic interference.

We recommend using insulated bearings for motors of size 250 and greater.

Further information can be requested from the HEW headquarters in Herford at any time.

5 Transportation, packaging and storage

Suspended loads

**WARNING!****Risk of fatal injury from suspended loads.**

When lifting loads there is a risk of fatal injuries from falling parts or parts swinging uncontrolledly.

Therefore:

- Never stand under suspended loads.
- Only use the stipulated fastening points.
- Do not fasten lifting gear to protruding machine parts or the lugs on attached parts. Make sure the fastening equipment is securely fastened.
- Only use approved lifting gear and fastening equipment with sufficient load bearing capacity.
- Do not use any torn or frayed ropes or belts.
- Do not attach ropes and belts to sharp edges and corners. Do not knot or twist them.

Off-centre centre of gravity

**WARNING!****Risk of falling due to an off-centre centre of gravity.**

Packages may have an off-centre centre of gravity. If fastened incorrectly the package may tilt and cause potentially fatal injury.

Therefore:

- Adhere to the markings on the packages.
- Attach the crane hook so that it is directly above the centre of gravity.
- Lift cautiously and observe whether the load tilts. If necessary change the fastening.

Transportation, packaging and storage

Improper transportation



CAUTION!
Risk of damage in case of improper transportation.

Improper transportation can cause considerable material damage.

Therefore:

- When unloading delivered packages and when transporting on the premises, proceed with caution and adhere to the symbols and instructions on the packaging.
- Only use the fastening points provided.
- Do not remove the packaging until shortly before installation.

5.1 Delivery inspection

Inspect the delivery for damage and to make sure it is complete immediately after receiving it.

Proceed as follows in case of visual external damage:

- Refuse delivery or accept delivery provisionally.
- Make a note of the extent of damage in the shipping documents or on the carrier's delivery note.
- Make a claim.



NOTE!

Make a claim for every discrepancy as soon as it is discovered. Claims for compensation can only be asserted within the valid claims periods.

Explosion protection



EXPLOSION PROTECTION!

Transport damage can cause a loss of the explosion protection.

- Do not put the machine into operation in case of visible transport damage. Contact the manufacturer.

Failure to adhere to these instructions will lead to a loss of the explosion protection.

5.2 Transportation

Fastening points

- Use suitable lifting gear.
- Use the lifting eyebolts provided on the motor.
- To transport machine sets (e.g. gear units, fan attachments etc.) only use the lifting eyebolts and lugs provided. Machine sets must not be lifted by the individual machines.
- Remove any transport safety devices which protect from bearing damage before commissioning.

Transporting packages by crane

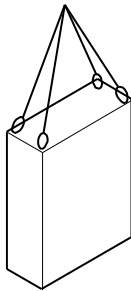

Fig. 7

Packages which have fastening eyebolts can be transported directly by crane on the following conditions:

- The crane and lifting gear must be designed for the weight of the packages.
- The operator must be authorised to operate the crane.

Fastening:

1. Fasten ropes, belts or multiple-point suspension gear according to Fig. 7.
2. Make sure that the package hangs straight, paying attention to the off-centre centre of gravity as necessary.
3. Begin transportation.

Transporting pallets by crane

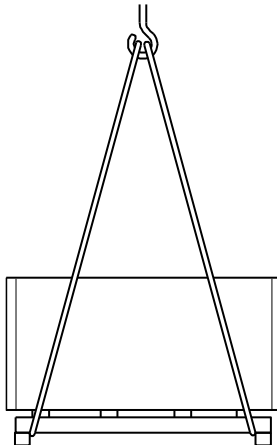

Fig. 8

Packages which are fastened to pallets can be transported by crane under the following conditions:

- The crane and lifting gear must be designed for the weight of the packages.
- The operator must be authorised to operate the crane.

Fastening:

1. Fasten ropes, belts or multiple-point suspension gear to the pallet according to Fig. 8.
2. Check that the packages are not damaged by the fastening equipment. If necessary use other fastening equipment.
3. Begin transportation.

Transportation, packaging and storage

Transporting pallets by forklift

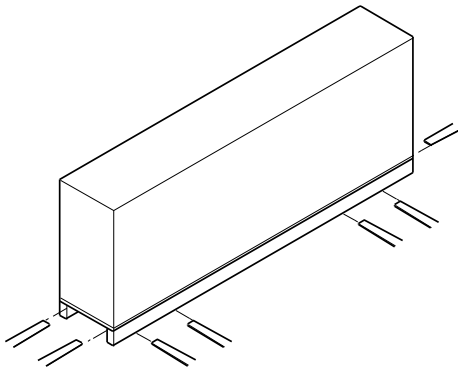

Fig. 9

Packages which are fastened to pallets can be transported by forklift under the following conditions:

- The forklift must be designed for the weight of the units for transportation.
- The driver must be authorised to drive the forklift.

Fastening:

1. Drive the forklift with the forks between or underneath the beams of the pallet.
2. Insert the forks so that they protrude on the opposite side.
3. Make sure that the pallet cannot tilt in case it has an off-centre centre of gravity.
4. Raise the package and begin transportation.

5.3 Packaging

Information on packaging

The individual packages are packaged appropriately for the expected transportation conditions. Only environmentally friendly materials have been used for packaging.

The packaging is designed to protect the individual parts from transport damage, corrosion and other damage up until they are installed. You must therefore not destroy the packaging and not remove it until shortly before installation.

Handling packaging materials

Dispose of packaging material in accordance with the respective valid laws and local regulations.



CAUTION!

Risk of environmental damage due to incorrect disposal.

Packaging materials are valuable raw materials and can be re-used in many cases or treated and recycled.

Therefore:

- Dispose of packaging material in an environmentally friendly manner.
- Adhere to the valid local regulations for disposal. Contract a specialist company to carry out disposal as necessary.

5.4 Storage

Storing packages

Store the packages under the following conditions:

- Do not store in the open.
- Keep in a dry and dust-free environment.
- Do not expose to any corrosive media.
- Protect from sunlight.
- Make sure to store in a low-vibration environment ($v_{\text{eff}} \leq 0.2 \text{ mm/s}$)
- Avoid large fluctuations in storage temperature.
- Relative humidity: max. 60 %.
- Check the insulation resistance as necessary (⇒chapter "Checking the insulation resistance").
- Grease or replace the rolling bearings as necessary (⇒ chapter "Maintenance").
- When storing for longer than 3 months, regularly check the general condition of all parts and the packaging. If necessary, replenish or replace the conservation.



NOTE!

In some cases there will be instructions for storage on the packages informing you of further requirements going beyond those listed here. Adhere to these instructions accordingly.

6 Installation and commissioning



NOTE!

When installing and commissioning adhere to the current standards and directive for electrical apparatus for explosive gas atmospheres.

6.1 Safety

Staff

- Installation and commissioning must only be performed by specialist staff with the appropriate qualifications.
- Work on the electrical equipment must only be carried out by qualified electricians.

Personal safety equipment and clothing

Wear the following safety equipment and clothing for all installation and commissioning work:

- Occupational safety clothing
- Safety shoes

Explosion protection



EXPLOSION PROTECTION!

The introduction of ignition sources such as sparks, open flames and hot surfaces can cause explosions in the potentially explosive area. Therefore, when carrying out all installation work on the machine in the potentially explosive area:

- Do not start any installation work without a written permit.
- Only carry out installation work to the exclusion of a potentially explosive atmosphere.
- Only use tools which are approved for use in the potentially explosive area.

Failure to adhere to these instructions will lead to a loss of the explosion protection.

Electrical equipment**DANGER!****Danger to life from electrical current.**

There is a risk of fatal injury from contact with live parts. Electrical components which are switched on can carry out uncontrolled movements and cause serious injuries.

Therefore:

- Before starting work switch off the electrical power supply and secure it to prevent it from being switched back on.

Securing the machine to prevent it from being switched back on**DANGER!****Risk of death from switching on without authorisation!**

When performing installation there is a risk that the energy supply will be switched on without authorisation. This puts the life of people in the danger area at risk.

Therefore:

- Before beginning all work shut off all energy supplies and secure them to prevent them from being switched back on.

Improper installation and commissioning**WARNING!****Risk of injuries from improper installation and commissioning.**

Improper installation and commissioning can cause serious personal injury and material damage.

Therefore:

- Before starting work make sure there is sufficient space for performing the installation work.
- Handle open, sharp-edged parts with care.
- Keep the installation area clean and tidy. Loose parts and tools stacked on top of each other or parts and tools left lying around are potential sources of accidents.
- Fit parts properly. Adhere to the stipulated tightening torque values for screws.
- Secure parts to prevent them from falling or toppling.

Installation and commissioning

6.2 Installation

6.2.1 Ventilation at the location for use

The ventilation for the motor must not be obstructed.

You must therefore adhere to the following points:

- Makes sure that there is sufficient space between the motor fan and the walls and other similar obstructions.
- The clearance to obstructions must be at least $d/4$ (d = diameter of the motor).
- Make sure that the exhaust air is not sucked directly back in.
- In case of heavy soiling clean the air ways regularly.

6.2.2 Types of construction as per EN 60034-7

Type of construction and IM code (international mounting) of the most frequently used versions.

Type of construction	Symbol	Explanation
IM B3 IM 1001		<ul style="list-style-type: none"> ■ 2 bearing covers ■ with feet
IM V5 IM 1011		<ul style="list-style-type: none"> ■ 2 bearing covers ■ with feet ■ Shaft end bottom ■ Fastening on the wall
IM V6 IM 1031		<ul style="list-style-type: none"> ■ 2 bearing covers ■ with feet ■ Shaft end top ■ Fastening on the wall
IM B6 IM 1051		<ul style="list-style-type: none"> ■ 2 bearing covers ■ with feet ■ Construction type IM B3 ■ Fastening on the wall ■ Feet left, viewed from drive side

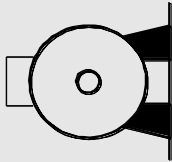
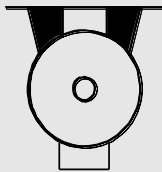
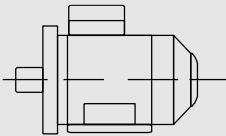
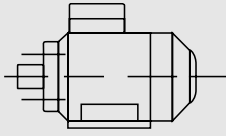
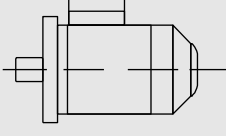
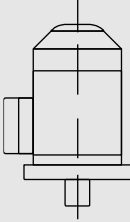
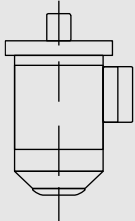
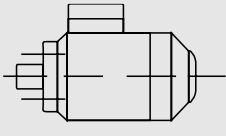
Type of construction	Symbol	Explanation
IM B7 IM 1061		<ul style="list-style-type: none"> ■ 2 bearing covers ■ with feet ■ Construction type IM B3 ■ Fastening on the wall ■ Feet right, viewed from drive side
IM B8 IM 1071		<ul style="list-style-type: none"> ■ 2 bearing covers ■ with feet ■ Construction type IM B3 ■ Fastening on the ceiling
IM B35 IM 2001		<ul style="list-style-type: none"> ■ 2 bearing covers ■ with feet ■ Securing flange type A
IM B34 IM 2101		<ul style="list-style-type: none"> ■ 2 bearing covers ■ with feet ■ Securing flange type C
IM B5 IM 3001		<ul style="list-style-type: none"> ■ 2 bearing covers ■ without feet ■ Securing flange type A
IM V1 IM 3011		<ul style="list-style-type: none"> ■ 2 bearing covers ■ without feet ■ Shaft end bottom ■ Securing flange type A
IM V3 IM 3031		<ul style="list-style-type: none"> ■ 2 bearing covers ■ without feet ■ Shaft end top ■ Securing flange type A
IM B14 IM 3601		<ul style="list-style-type: none"> ■ 2 bearing covers ■ without feet ■ Securing flange type C

Installation and commissioning

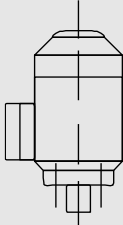
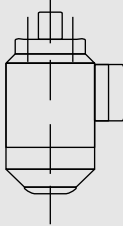
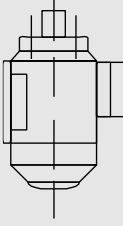
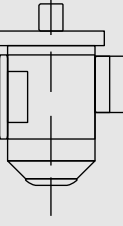
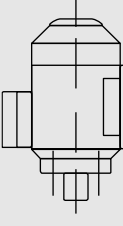
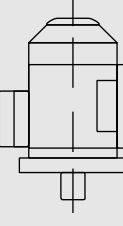
Type of construction	Symbol	Explanation
IM V18 IM 3611		<ul style="list-style-type: none"> ■ 2 bearing covers ■ without feet ■ Shaft end bottom ■ Securing flange type C
IM V19 IM 3631		<ul style="list-style-type: none"> ■ 2 bearing covers ■ without feet ■ Shaft end top ■ Securing flange type C
IM V6/IM V19		<ul style="list-style-type: none"> ■ 2 bearing covers ■ with feet ■ Shaft end top ■ Securing flange type C
IM V36 IM 2031		<ul style="list-style-type: none"> ■ 2 bearing covers ■ with feet ■ Shaft end top ■ Securing flange type A
IM V5/IM V18		<ul style="list-style-type: none"> ■ 2 bearing covers ■ with feet ■ Shaft end bottom ■ Securing flange type C
IM V15 IM 2011		<ul style="list-style-type: none"> ■ 2 bearing covers ■ with feet ■ Shaft end bottom ■ Securing flange type A

6.2.3 Erecting the machine



DANGER!
Risk of death due to insufficient protection classes.

Insufficient protection classes can lead to considerable material damage, serious personal injury or even death.

Therefore:

- Do not erect machines of protection class \leq IP23 in the open.

In order to ensure that the machine runs quietly and with low vibrations make sure of the following when erecting the machine:

- the foundation must be stable
- the foundation's natural frequency with the machine must be sufficiently different to the rotary frequency and the double mains frequency
- the motors must be aligned accurately
- the drive machines must be well balanced

6.2.4 Installation

Installation varies depending on the construction type. In case you have any doubts contact the service department (\Rightarrow page 2).

When installing, always pay attention to the following points:

- All connection elements (walls, ceilings etc.) must be of sufficient size.
- The rotor is dynamically balanced with a half feather key. Take this into account when balancing the drive element.
- Avoid incorrect belt tension (\Rightarrow catalogue). Cover couplings and belt pulleys with a guard to protect accidental contact.
- Fit and remove drive elements (couplings, belt pulley, toothed wheels etc.) with the suitable devices.
- Tighten all screw connections with the appropriate tightening torque (\Rightarrow chapter "Tightening torque values for screws").
- Fit construction types with the shaft ends at the bottom with a cover to prevent foreign bodies from falling into the motor's fan.
- Any condensation drain holes must be positioned at the lowest point of the motor when installed and cleaned of any impurities.
- Take generally required measures for preventing accidental contacts between drive elements

6.3 Connecting to the energy supply

Electrical current



DANGER!

Danger to life from electrical current.

There is an immediate risk of fatal injury in case of contact with live parts. Damage to the insulation or individual components can mean danger to life.

Therefore:

- In case of damage to the insulation, switch off the power supply immediately and have repairs carried out.
- Have work on the electrical equipment carried out by qualified electricians only.
- When any work is carried out on the electrical equipment, disconnect it from the power and make sure it is free of voltage.
- Before carrying out maintenance, cleaning and repair work, switch off the power supply and secure it to prevent it from being switched back on.
- Do not jumper or disable any fuses or circuit breakers. When replacing fuses or circuit breakers make sure to adhere to the correct ampere rating.
- Keep moisture away from live parts. It can lead to a short circuit.

6.3.1 Screwed cable gland



NOTE!

Type Ex de motors are equipped with EEx e screwed cable glands. For type EEx d motors, the cable glands are not included in the scope of delivery. These must be adapted to the cable diameter on site.



NOTE!

Unused cable bushing openings must be sealed off with certified plugs with the matching IP protection type as shown on the type plate.

Ex d motors

1. Connection to the terminal box with these motors is implemented with a standard connection.
2. You must take great care when selecting the cable connection. It is imperative that the version is approved and approved for at least the protection class of the motor.
3. The type and dimensions of the cable connections must match the cable type and cable cross section.

Ex de motors

1. Strictly adhere to the directives and standards which apply to the terminal box connections of these motors. The type of cable connection must be approved.
2. Make sure that the supply cable is connected in line with the instructions of the wiring diagram in the terminal box.
3. Properly insert the seals on the terminal box into the grooves provided.
4. Creepage paths and air gaps must comply with EN 60079-7.

6.3.2 Voltage and circuit

- Adhere to the wiring specification on the type plate and wiring diagram in the terminal box.
- Compare the operating voltages and supply voltages.
- Motor rated voltages and the supply voltage must not differ $\pm 5\%$; $\pm 2\%$ is permitted for the rated frequency.

Installation and commissioning

6.3.3 Checking the insulation resistance

- To be performed by a qualified electrician only

**DANGER!****Risk of death due to uncontrolled fault currents.**

Insulation faults can call potentially fatal fault currents.

Therefore:

- The value of the insulation resistance must be higher than the critical value of 0.5 MΩ.
- In case the value drops below the critical insulation resistance, take the motor out of operation and shut it down immediately.

**DANGER!****Danger to life from electrical current.**

When measuring and immediately afterwards the terminals carry partly dangerous voltages.

Therefore:

- Do not touch the terminals.
- Discharge after measuring.

Before commissioning the motor, after a longer period of storage or without use, the insulation resistance of the coils has to be determined again. When doing so, adhere to the valid standards and directives.

6.4 Commissioning

**DANGER!****Danger to life from electrical current.**

There is an immediate risk of fatal injury in case of contact with live parts.

Therefore:

- Only carry out work with the plant free of voltage.
- Secure the plant to prevent it from being switched back on.

**CAUTION!**

Risk of personal injury and/or material damage from feather keys ejected at speed.

When commissioning a motor without drive elements the feather keys may be ejected at speed.

Therefore:

- Before commissioning motors without drive elements remove or secure the feather keys beforehand.

Before commissioning make sure that:

- the minimum insulation resistance values are adhered to (⇒ chapter "Checking the insulation resistance").
- the protective earth conductor connection is properly established and, where necessary, a potential equalisation has been established (see DIN EN 60079-14, chapter 6.3)
- the rotor can be turned without rubbing.
- the motor is properly fitted and aligned.
- the drive elements have the right settings (e.g. belt tension for belt drive etc.)
- the drives are suitable for the conditions of use.
- all electrical connections, fastening screws and fastening elements are the right type and are tightened properly.
- measures to prevent accidental contacts for mowing and live parts have been taken.

**NOTE!**

Commissioning is performed using the overall plant control unit (⇒ Operating manual for the complete plant).

7 Operations

7.1 General information

During operation no staff are required in the machine area or in the direct vicinity to operate it.

Operation is performed using the overall plant control unit (⇒ Operating manual for the complete plant).

7.2 Shutting down in an emergency

In danger situations machine movements must be stopped as quickly as possible and the energy supply has to be switched off.

Shutting down in an emergency

In case of danger proceed as follows:

1. Trigger an emergency stop immediately.
2. Remove any people from the danger zone and administer first aid.
3. Alert a doctor and the fire services.
4. Inform the responsible party at the location.
5. Switch off the master switch and secure it to prevent it from being switched back on.
6. Keep access routes for emergency vehicles clear.
7. If the seriousness of the emergency requires it, inform the respective authorities.
8. Have specialist staff remedy the fault.

After emergency measures



WARNING!

Risk of death from switching on prematurely.

When switching back on there is a risk of fatal injury for all people in the danger area.

Therefore:

- Before switching back on make sure that there is nobody in the danger area.

9. Before re-starting check the plant and make sure that all safety devices are installed and fully functional.

8 Faults

The following chapter describes possible causes of faults and the work to eradicate them.

In case of faults which occur several times, reduce the maintenance interval accordingly to suit the actual strain.

In case of faults which cannot be cleared using the following instructions, contact the manufacturer, see service address on page 2.

8.1 Safety

Staff

- Some tasks can only be carried out by specialist staff with special qualifications or exclusively by the manufacturer. The description of the respective individual fault makes reference to this in each case.
- Work on the electrical equipment must only be carried out by qualified electricians.

Personal safety equipment and clothing

Wear the following safety equipment and clothing for all faults work:

- Occupational safety clothing
- Safety shoes

Explosion protection



EXPLOSION PROTECTION!

The introduction of ignition sources such as sparks, open flames and hot surfaces can cause explosions in the potentially explosive area.

Therefore, when carrying out all work to remedy faults in the potentially explosive area:

- Do not start any work without a written permit.
- Only carry out work to remedy faults to the exclusion of a potentially explosive atmosphere.
- Only use tools which are approved for use in the potentially explosive area.

Failure to adhere to these instructions will lead to a loss of the explosion protection.

Faults

Electrical equipment

**DANGER!****Danger to life from electrical current.**

There is a risk of fatal injury from contact with live parts. Electrical components which are switched on can carry out uncontrolled movements and cause serious injuries.

Therefore:

- Before starting work switch off the electrical power supply and secure it to prevent it from being switched back on.

Securing the machine to prevent it from being switched back on

**DANGER!****Risk of death from switching on without authorisation!**

When working to remedy faults there is a risk that the energy supply will be switched on without authorisation. This puts the life of people in the danger area at risk.

Therefore:

- Before beginning all work shut off all energy supplies and secure them to prevent them from being switched back on.

Improper eradication of faults

**WARNING!****Risk of injuries from incorrectly eradicating faults.**

Eradicating faults incorrectly can cause serious personal injury and material damage.

Therefore:

- Before starting work make sure there is sufficient space for performing the installation work.
- Keep the installation area clean and tidy. Loose parts and tools stacked on top of each other or parts and tools left lying around are potential sources of accidents.
- If parts have been removed, make sure they are installed properly, re-install all fastening elements and adhere to the tightening torque values for screws.

How to act in case of faults

The following basic instructions apply:

1. In case of faults which pose an immediate risk to people or objects of material value, activate the emergency stop function immediately.
2. Determine the cause of the fault.
3. If eradicating the fault requires work in the danger area, switch off the plant and secure it to prevent it from being switched back on.
4. Inform the responsible party at the location of the fault immediately.
5. Depending on the type of fault, have it remedied by specialist staff or remedy it yourself.



NOTE!

The following fault table provides information on who is authorised to remedy the fault.

8.2 Fault table

Fault	Possible cause	Remedy	To be remedied by
<ul style="list-style-type: none"> ■ Bearing is too warm 	Too much grease in the bearing	Remove excessive grease	Qualified specialist
	Bearing is soiled	Replace the bearing	Manufacturer
	Belt tension too high	Reduce belt tension	Qualified specialist
	Bearing grease dark in colour	Check for bearing currents	Qualified specialist
<ul style="list-style-type: none"> ■ Bearing is too warm ■ Motor is not running smoothly 	Coupling forces are pulling or pushing	Align the motor exactly, adjust the coupling	Qualified specialist
<ul style="list-style-type: none"> ■ Bearing is too warm ■ Bearing noises 	Not enough grease in the bearing	Lubricate as stipulated	Qualified specialist
<ul style="list-style-type: none"> ■ Bearing is too warm ■ Bearing noises ■ Motor is not running smoothly 	Motor erected incorrectly	Check the motor construction type	Qualified specialist



Faults

Fault	Possible cause	Remedy	To be remedied by
<ul style="list-style-type: none"> ■ Bearing noises 	Scoring on inner bearing ring, e.g. from motor starting up with bearing locked	Replace bearing, avoid vibrations when at a standstill	Manufacturer
<ul style="list-style-type: none"> ■ Motor is not running smoothly 	Imbalance due to belt pulley or coupling	Balance exactly	Manufacturer
	Machine fastening insufficient	Check machine fastening	Qualified specialist
<ul style="list-style-type: none"> ■ Motor does not start up ■ Considerable drop in speed 	Load moment too high	Check motor torque and load moment	Qualified electrician
	Supply voltage too low	Check power supply conditions	Qualified electrician
<ul style="list-style-type: none"> ■ Motor does not start up ■ Considerable drop in speed ■ Safety device is triggered 	Phase interrupted	Check the mains connection	Qualified electrician
<ul style="list-style-type: none"> ■ Motor does not start up ■ Motor is too warm ■ Considerable drop in speed ■ Safety device is triggered 	Incorrect circuit	Adhere to wiring diagram and type plate	Qualified electrician
<ul style="list-style-type: none"> ■ Motor is too warm ■ Considerable drop in speed ■ Safety device is triggered 	Overload	Adhere to stipulations on type plate	Qualified electrician
<ul style="list-style-type: none"> ■ Motor is too warm ■ Safety device is triggered 	Too many switching actuations	Observe rated operating mode	Qualified electrician
<ul style="list-style-type: none"> ■ Motor is too warm 	Ventilation insufficient	Check cooling air routes, check direction of rotation	Qualified electrician
	Ventilation ducts soiled	Clean the ventilation ducts	Qualified specialist
<ul style="list-style-type: none"> ■ Safety device is triggered 	Coil or terminal short circuit	Measure the insulation resistance	Qualified electrician
	The start-up time has been exceeded	Check the start-up conditions	Qualified electrician

8.3 Commissioning after remedied fault

After remedying the fault carry out the following steps for re-commissioning:

1. Reset the emergency stop devices.
2. Acknowledge the fault on the control unit.
3. Make sure that there is nobody in the danger area.
4. Start by following the instructions in the chapter "Operation".

Explosion protection



EXPLOSION PROTECTION!

Introducing ignition sources such as sparks in the potentially explosive area can cause explosions. Therefore, after carrying out all work to remedy faults in the potentially explosive area:

- Make sure that all aggregates are connected to each other with potential equalisation of sufficient dimensions. To be performed by a qualified electrician only.
- Make sure that the motor is earthed to prevent static charging. To be performed by a qualified electrician only.

Failure to adhere to these instructions will lead to a loss of the explosion protection.

9 Maintenance

9.1 Safety

Staff

- The maintenance work described here can be carried out by the operator unless otherwise stated.
- Some maintenance tasks can only be carried out by specialist staff with special qualifications or exclusively by the manufacturer. The description of the respective individual maintenance task makes reference to this in each case.
- Work on the electrical equipment must only be carried out by qualified electricians.

Personal safety equipment and clothing

Wear the following safety equipment and clothing for all maintenance work:

- Occupational safety clothing
- Safety shoes

Explosion protection



EXPLOSION PROTECTION!

The introduction of ignition sources such as sparks, open flames and hot surfaces can cause explosions in the potentially explosive area.

Therefore, when carrying out all maintenance work on the machine in the potentially explosive area:

- Do not start any maintenance work without a written permit.
- Only carry out maintenance work to the exclusion of a potentially explosive atmosphere.
- Only use tools which are approved for use in the potentially explosive area.

Failure to adhere to these instructions will lead to a loss of the explosion protection.

Electrical equipment**DANGER!****Danger to life from electrical current.**

There is a risk of fatal injury from contact with live parts. Electrical components which are switched on can carry out uncontrolled movements and cause serious injuries.

Therefore:

- Before starting work switch off the electrical power supply and secure it to prevent it from being switched back on.

Securing the machine to prevent it from being switched back on**DANGER!****Risk of death from switching on without authorisation!**

When performing maintenance there is a risk that the energy supply will be switched on without authorisation. This puts the life of people in the danger area at risk.

Therefore:

- Before beginning all work shut off all energy supplies and secure them to prevent them from being switched back on.

Improperly performed maintenance work**WARNING!****Risk of injury due to improperly performed maintenance work.**

Performing maintenance incorrectly can cause serious personal injury and material damage.

Therefore:

- Before starting work make sure there is sufficient space for performing the installation work.
- Keep the installation area clean and tidy. Loose parts and tools stacked on top of each other or parts and tools left lying around are potential sources of accidents.
- If parts have been removed, make sure they are installed properly, re-install all fastening elements and adhere to the tightening torque values for screws.

Environmental protection

Adhere to the following instructions on environmental protection when performing maintenance work:

Maintenance

- At all lubricating points which are supplied with lubricant by hand, remove the expelled, used or excess grease and dispose of it in accordance with the local regulations.
- Collect replaced oil in suitable containers and dispose of it in accordance with the local regulations.

9.2 Cleaning

- Additionally required safety equipment and clothing:
 - Light breathing mask

Explosion protection



EXPLOSION PROTECTION!

Swirled up deposits of dust can form potentially explosive dust/air mixtures and when ignition sources are introduced, such as sparks, open flames and hot surfaces, can cause explosions in the potentially explosive area.

Therefore:

- Prevent layers of dust deposits from exceeding a thickness of 5 mm by regularly cleaning the location.
- Only carry out cleaning work to the exclusion of a potentially explosive atmosphere.
- Only use cleaning implements which are approved for use in the potentially explosive area.
- Wear personal safety equipment and clothing.

Failure to adhere to these instructions will lead to a loss of the explosion protection.

- Do not spray electrical machines with water or other liquids.
- Check the entire route for cooling air for soiling at least once a year.

9.3 Maintenance schedule

The next sections describe maintenance work which is required to ensure optimum and fault-free operation.

If during regular checks increased wear is identified, shorten the required maintenance intervals to match the actual signs of wear.

In case you have any questions on maintenance work and intervals, contact the manufacturer, see service address on page 2.

The standard version motors are fitted with permanently lubricated bearings.

Motors from construction type 160 and above can be fitted with lubricating equipment. The lubricating intervals depend on many influence factors. The values in the table below apply under normal operating conditions.

Before lubricating, remove the plug screw on the side opposite the grease nipple and screw it back in when finished.



NOTE!

In case of questions on lubrication, contact the manufacturer.

See page 2 for contact details.

Lubricating the ball bearings - intervals in operating hours

Size	Quantity of grease [g]	Speed [min ⁻¹]					
		3600	3000	1800	1500	1000	500
160	25	7000	9500	14000	17000	21000	24000
180	30	6000	8000	13500	16000	20000	23000
200	40	4000	6000	11000	13000	17000	21000
225	50	3000	5000	10000	12500	16500	20000

Maintenance

9.4 Tightening torque values for screws

Explosion protection



EXPLOSION PROTECTION!

The introduction of ignition sources such as sparks, open flames and hot surfaces can cause explosions in the potentially explosive area.

Therefore, when carrying out all maintenance work on the machine in the potentially explosive area:

- Do not start any maintenance work without a written permit.
- Only carry out maintenance work to the exclusion of a potentially explosive atmosphere.
- Only use tools which are approved for use in the potentially explosive area.

Failure to adhere to these instructions will lead to a loss of the explosion protection.



NOTE!

Strength class 8.8 screws must be used for all screwed connections which are used to seal the pressure-resistant space.

Replace screws which can no longer be used with new screws of the same type and strength class.

If not otherwise stated, the following tightening torque values apply for screw connections.

9.4.1 Tightening torque values for screws for electrical connections

Thread	Tightening torque value [Nm]	Thread	Tightening torque value [Nm]
M 4	1.2	M 12	15.5
M 5	2	M 16	30
M 6	3	M 20	52
M 8	6	M 24	80
M 10	10	M 30	150

9.4.2 Screw connections, property class 8.8 and A4-70

**NOTE!**

Only use tightening torque values for screws of property class 8.8 and A4-70 (A4-80) in high-strength parts (e.g. grey cast iron, steel).

Thread	Tightening torque value [Nm]	Thread	Tightening torque value [Nm]
M 4	2.3	M 14	105
M 5	4.6	M 16	160
M 6	7.9	M 20	330
M 8	19	M 24	560
M 10	38	M 30	1100
M 12	66	M 36	1900

9.4.3 Screw connections of property class 5.6

**NOTE!**

Only use tightening torque values for screws of property class 5.6, 4.6 A2 or for screws in low-strength parts (e.g. aluminium).

Thread	Tightening torque value [Nm]	Thread	Tightening torque value [Nm]
M 4	1.1	M 14	49
M 5	2.1	M 16	75
M 6	3.7	M 20	150
M 8	8.9	M 24	260
M 10	18	M 30	520
M 12	30	M 36	920

9.5 Measures on completion of maintenance

Explosion protection



EXPLOSION PROTECTION!

Introducing ignition sources such as sparks in the potentially explosive area can cause explosions. Therefore, after carrying out all maintenance work on the machine in the potentially explosive area:

- Make sure that all aggregates are connected to each other with potential equalisation of sufficient dimensions. To be performed by a qualified electrician only.
- Make sure that the motor is earthed to prevent static charging. To be performed by a qualified electrician only.

Failure to adhere to these instructions will lead to a loss of the explosion protection.

On completion of maintenance work, carry out the following steps before switching on:

1. Check that all screw connections which have been unfastened are fastened securely again.
2. Check whether all the safety devices and covers which have been removed have been properly re-installed.
3. Make sure that all tools, materials and other equipment which have been used, have been removed from the working area.
4. Clean the working area and remove any substances, e.g. liquids, processing material etc.
5. Make sure that all the plant's safety devices are in perfect working order.

10 Removal

Once the period of use has expired, the machine must be removed and disposed of in an environmentally friendly manner.

10.1 Safety

Staff

- The machine must only be removed by qualified specialist staff with the appropriate qualifications.
- Work on the electrical equipment must only be carried out by qualified electricians.

Explosion protection



EXPLOSION PROTECTION!

The introduction of ignition sources such as sparks, open flames and hot surfaces can cause explosions in the potentially explosive area.

Therefore, when carrying out all removal work on the machine in the potentially explosive area:

- Do not start any removal work without a written permit.
- Only carry out removal work to the exclusion of a potentially explosive atmosphere.
- Only use tools which are approved for use in the potentially explosive area.

Failure to adhere to these instructions will lead to a loss of the explosion protection.

Electrical equipment



DANGER!

Danger to life from electrical current.

There is a risk of fatal injury from contact with live parts. Electrical components which are switched on can carry out uncontrolled movements and cause serious injuries.

Therefore:

- Before starting removal work switch off the electrical supply and disconnect it permanently.

Removal

Improper removal



WARNING!

Risk of injury from improper removal.

Stored residual energy, sharp parts, points and corners on and in the device or on the required tools can cause injuries.

Therefore:

- Before starting work make sure there is sufficient space.
- Handle open, sharp-edged parts with care.
- Keep the working area clean and tidy. Loose parts and tools stacked on top of each other or parts and tools left lying around are potential sources of accidents.
- Remove parts properly. Be aware that some parts have a heavy dead weight. Use lifting gear as necessary.
- Secure parts to prevent them from falling or toppling.
- In case of doubt, contact the manufacturer.

10.2 Removal

Before starting removal:

- Switch off the machine and secure it to prevent it from being switched back on.
- Physically disconnect the entire energy supply and discharge stored residual energy.
- Remove fuels and consumables and residual processing materials and dispose of them in an environmentally friendly manner.

Then clean assembly groups and parts properly and dismantle then in accordance with the local regulations for occupational safety and environmental protection.

10.3 Disposal

If no agreements have been made for return or disposal, have the dismantled components recycled:

- Have metals scrapped.
- Hand over plastic elements for recycling.
- Sort and dispose of other components according to the material properties.

**CAUTION!**

Risk of environmental damage due to incorrect disposal.

Electrical scrap, electronic components, lubricants and consumables require special waste treatment and must only be disposed of by approved specialist companies.

The local authorities or specialist disposal companies can provide information on environmentally friendly disposal.

EC / EU – declaration of conformity



HERFORDER ELEKTROMOTOREN-WERKE GmbH & Co. KG

D – 32051 Herford
D – 32008 Herford

Goebenstraße 106
post office box 1852

Tel.: 05221 59040

info@HEW-HF.de

Electrical operating equipment:

Explosion-proof three phase asynchronous motors (flame-proof encapsulation) with squirrel cage

Typ	marking gas	marking dust
DCEx 63	II 2G Ex db e IIC T4-T6 Gb oder II 2G Ex db IIC T4-T6 Gb	
DBEx 63	II 2G Ex db e IIB T4-T6 Gb oder II 2G Ex db IIB T4-T6 Gb	
DDEx 63	II 2G Ex db e IIC T4-T6 Gb oder II 2G Ex db IIC T4-T6 Gb	II 2D Ex tb IIIC T135°C - 85°C Db
DCEx 71 - 225	II 2G Ex db eb IIC T4-T6 Gb oder II 2G Ex db IIC T4-T6 Gb	
DBEx 71 - 225	II 2G Ex db eb IIB T4-T6 Gb oder II 2G Ex db IIB T4-T6 Gb	
DDEx 71 - 225	II 2G Ex db eb IIC T4-T6 Gb oder II 2G Ex db IIC T4-T6 Gb	II 2D Ex tb IIIC T135°C - 85°C Db
DCEx 250 and DCEx 280	II 2G Ex db eb IIC T4-T6 Gb oder II 2G Ex db IIC T4-T6 Gb	
DBEx 250 and DBEx 280	II 2G Ex db eb IIB T4-T6 Gb oder II 2G Ex db IIB T4-T6 Gb	
DDEx 250 and DDEx 280	II 2G Ex db eb IIC T4-T6 Gb oder II 2G Ex db IIC T4-T6 Gb	II 2D Ex tb IIIC T135°C - 85°C Db
DEx 315	II 2G Ex de IIC T4-T6 oder II 2G Ex d IIC T4-T6	

are conform to the regulations of the following European directives:

- EMV- directive 2014/30/EU
- ATEX- directive 2014/34/EU
- RoHS- directive 2011/65/EU and (Amendment Annex II (EU) 2015/863)
- Electric motor Regulation 2019/1781/EU
- Machinery directive 2006/42/EC

The compliance with the provisions of the directives is proved by the following series of standards with all relevant parts according to the current date:

- DIN EN 60034
- DIN EN 60079-0:2018, 60079-1:2014, 60079-7:2015 + A1:2018, 60079-31:2014

The following EG/EU-type examination certificate is valid:

D_ Ex 63: SIQ 16 ATEX 142 X ((0158 DEKRA DTC GmbH
D_ Ex 71 – 225: BVS 14 ATEX E 114 X ((0158 DEKRA DTC GmbH
D_ Ex 250: BVS 19 ATEX E 005 X ((0158 DEKRA DTC GmbH
D_ Ex 280: BVS 19 ATEX E 006 X ((0158 DEKRA DTC GmbH
DEx 315: PTB 10 ATEX 1047 X ((0158 DEKRA DTC GmbH

The designated product is to be seen as a component for installation into a machine or system.

Commissioning is prohibited until the conformity of the final product to the directive 2006/42/EC is established.

(M. Scheidt) Managing Director

date 30.06.2021

The safety instructions of the product documentation must be duly observed.

This declaration of conformity is no warranty of the characteristics in the sense of product liability.

13.3 Coupling

For further information, see also

- Rotex-BA.pdf



ROTEX®

Torsionally flexible jaw couplings type

No. 001 - shaft coupling,
No. 018 - DKM,
with taper clamping sleeve
and their combinations

according to directive 2014/34/EU

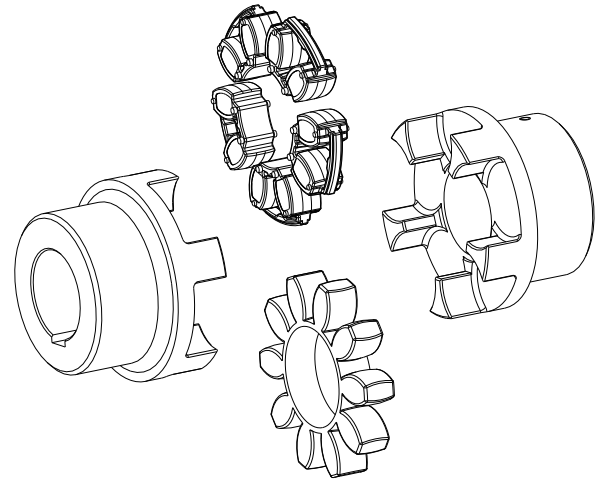

Type No. 001 - shaft coupling

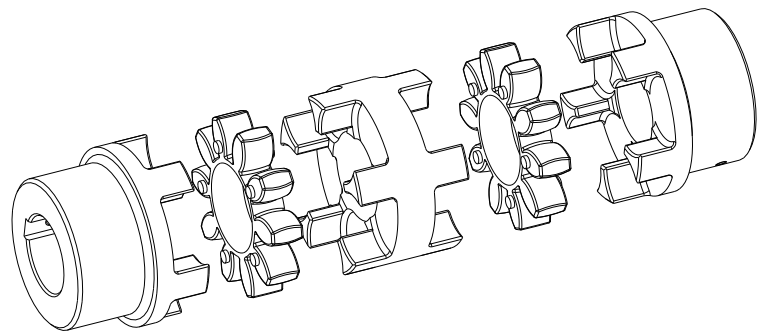



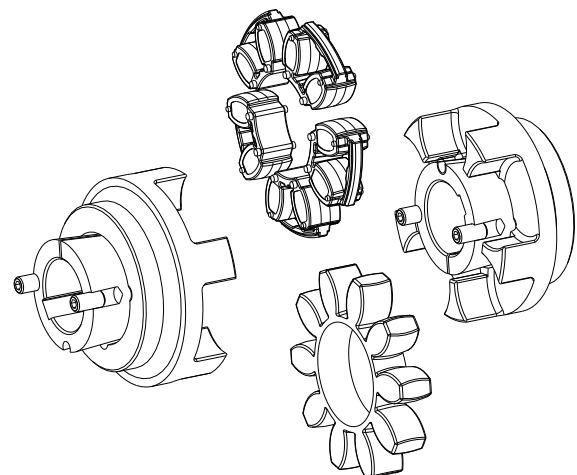

**Type No. 018 - DKM
double-cardanic coupling**



Type with taper clamping sleeve

ROTEX® is a torsionally flexible jaw coupling. It is able to compensate for shaft misalignment, for example caused by manufacturing inaccuracies, thermal expansion, etc.

Table of contents

1	Technical data	3
2	Advice	7
2.1	General advice	7
2.2	Safety and advice symbols	8
2.3	General hazard warnings	8
2.4	Intended use	8
2.5	Coupling selection	9
2.6	Reference to EC Machinery Directive 2006/42/EC	9
3	Storage, transport and packaging	9
3.1	Storage	9
3.2	Transport and packaging	9
4	Assembly	10
4.1	Components of the coupling	10
4.2	Advice for finish bore	11
4.3	Assembly of the hubs	12
4.4	Assembly of taper clamping sleeve	13
4.5	Displacements - alignment of the couplings	14
5	Start-up	16
6	Breakdowns, causes and elimination	17
7	Disposal	19
8	Maintenance and service	19
9	Spares inventory, customer service addresses	19
10	Enclosure A	
	Advice and instructions regarding the use in  potentially explosive atmospheres	20
10.1	Intended use in  potentially explosive atmospheres	21
10.2	Inspection intervals for couplings in  potentially explosive atmospheres	22
10.3	Standard values of wear	24
10.4	 marking of coupling for potentially explosive atmospheres	25
10.5	EU Certificate of conformity	27

1 Technical data

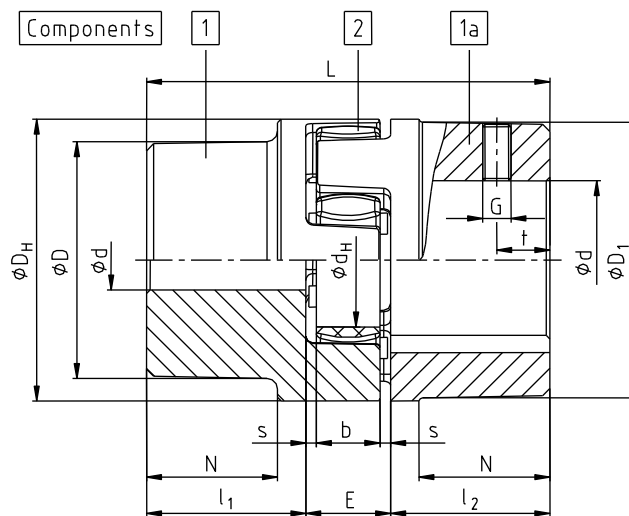

Illustration 1: ROTEX® (material: powder metal, Al-D and Al-H)

Table 1: Material powder metal steel (Sint)

Size	Component	Spider ¹⁾ (component 2) Rated torque [Nm]			Finish bore ²⁾ d (min-max)	Dimensions [mm] ³⁾										
		92 ShA	98 ShA	64 ShD		General										
						L	l ₁ , l ₂	E	b	s	D _H	D _Z	D _{Z1} ⁴⁾	d _H	D ₁	N
14	1a	7.5	12.5	-	6 - 16	35	11	13	10	1.5	30	-	-	10	-	-
19	1a	10	17	-	6 - 24	66	25	16	12	2.0	40	-	-	18	-	-
24	1a	34	60	-	9 - 28	78	30	18	14	2.0	56	-	-	27	-	-

Table 2: Material aluminium diecast (Al-D) - no approval for ATEX

Size	Component	Spider ¹⁾ (component 2) Rated torque [Nm]			Finish bore ²⁾ d (min-max)	Dimensions [mm] ³⁾										
		92 ShA	98 ShA	64 ShD		General										
						L	l ₁ , l ₂	E	b	s	D _H	D _Z	D _{Z1} ⁴⁾	d _H	D ₁	N
19	1	10	17	-	6 - 19	66	25	16	12	2.0	41	-	-	18	32	20
	19 - 24				41											
24	1	35	60	-	9 - 24	78	30	18	14	2.0	56	-	-	27	40	24
	22 - 28				56											
28	1	95	160	-	10 - 28	90	35	20	15	2.5	67	-	-	30	48	28
	28 - 38				67											

Table 3: Material aluminium (Al-H)

Size	Component	Spider ¹⁾ (component 2) Rated torque [Nm]			Finish bore ²⁾ d (min-max)	Dimensions [mm] ³⁾										
		92 ShA	98 ShA	64 ShD		General										
						L	l ₁ , l ₂	E	b	s	D _H	D _Z	D _{Z1} ⁴⁾	d _H	D ₁	N
5	1a	0.5	0.9	-	0 - 6	15	5	5	4	0.5	10	-	-	-	-	-
7	1a	1.2	2.0	2.4	0 - 7	22	7	8	6	1.0	14	-	-	-	-	-
9	1a	3.0	5.0	6.0	0 - 11	30	10	10	8	1.0	20	-	-	7.2	-	-
12	1a	5.0	9.0	12	0 - 12	34	11	12	10	1.0	25	-	-	8.5	-	-
14	1a	7.5	12.5	16	0 - 16	35	11	13	10	1.5	30	-	-	10.5	-	-
19	1a	10	17	26	0 - 24	66	25	16	12	2.0	40	-	-	18	-	-
24	1a	35	60	75	0 - 28	78	30	18	14	2.0	55	-	-	27	-	-
28	1a	95	160	200	0 - 38	90	35	20	15	2.5	65	-	-	30	-	-
38	1a	190	325	405	0 - 45	114	45	24	18	3.0	80	-	-	38	-	-
42	1a	265	450	560	0 - 55	126	50	26	20	3.0	95	-	-	46	-	-
48	1a	310	525	655	0 - 62	140	56	28	21	3.0	105	-	-	51	-	-

- 1) Maximum torque of the coupling $T_{Kmax.}$ = rated torque of the coupling $T_{K rated}$ x 2
- 2) Bores H7 with keyway to DIN 6885 sheet 1 [JS9] and setscrew
- 3) For dimensions G and t see table 8; there is a setscrew on the keyway (only with Al-D opposite the keyway)
- 4) D_{Z1} = internal diameter of housing

Please observe protection note ISO 16016.	Drawn:	2019-07-02 Pz/Wb	Replacing:	KTR-N dated 2017-09-06
	Verified:	2019-07-23 Pz	Replaced by:	



1 Technical data

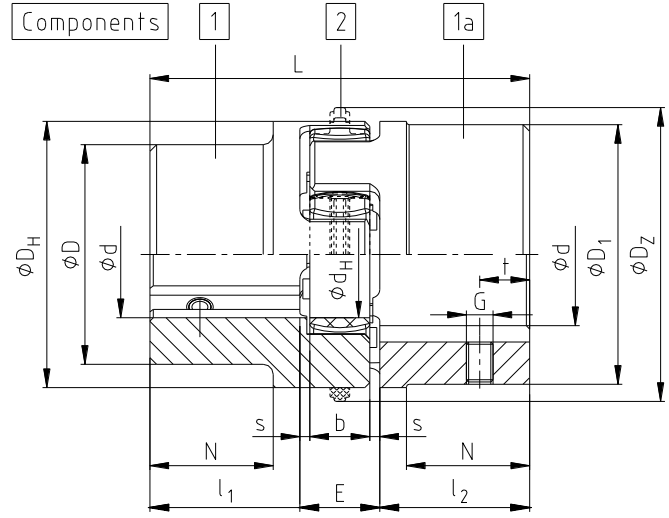

Illustration 2: ROTEX® (material: GJL/GJS)

Table 4: Material cast iron (GJL)/nodular iron (GJS)

Size	Component	Spider ¹⁾ (component 2)			Dimensions [mm] ³⁾												
		Rated torque [Nm]			Finish bore ²⁾ d (min-max)	General											
		92 ShA	98 ShA	64 ShD		L	l ₁ , l ₂	E	b	s	D _H	D _Z	D _{Z1} ⁴⁾	d _H	D, D ₁	N	
Cast iron (GJL)																	
38	1	190	325	405	12 - 40	114	45	24	18	3.0	80	-	-	38	66	37	
	38 - 48				78												
	12 - 48				164										70		62
42	1	265	450	560	14 - 45	126	50	26	20	3.0	95	-	-	46	75	40	
	42 - 55				176										75		94
	14 - 55				176										75		65
48	1	310	525	655	15 - 52	140	56	28	21	3.5	105	-	-	51	85	45	
	48 - 62				188										80		104
	15 - 62				188										80		69
55	1	410	685	825	20 - 60	160	65	30	22	4.0	120	-	-	60	98	52	
	55 - 74				118												
65	1	625	940	1175	22 - 70	185	75	35	26	4.5	135	-	-	68	115	61	
75	1	1280	1920	2400	30 - 80	210	85	40	30	5.0	160	-	-	80	135	69	
90	1	2400	3600	4500	40 - 97	245	100	45	34	5.5	200	218	230	100	160	81	
Nodular iron (GJS)																	
100	1	3300	4950	6185	50 - 115	270	110	50	38	6.0	225	246	260	113	180	89	
110	1	4800	7200	9000	60 - 125	295	120	55	42	6.5	255	276	290	127	200	96	
125	1	6650	10000	12500	60 - 145	340	140	60	46	7.0	290	315	330	147	230	112	
140	1	8550	12800	16000	60 - 160	375	155	65	50	7.5	320	345	360	165	255	124	
160	1	12800	19200	24000	80 - 185	425	175	75	57	9.0	370	400	415	190	290	140	
180	1	18650	28000	35000	85 - 200	475	185	85	64	10.5	420	450	465	220	325	156	

1) Maximum torque of the coupling $T_{Kmax.} = \text{rated torque of the coupling } T_{K \text{ rated}} \times 2$
 2) Bores H7 with keyway to DIN 6885 sheet 1 [JS9] and setscrew
 3) For dimensions G and t see table 8; there is a setscrew on the keyway
 4) D_{Z1} = internal diameter of housing



1 Technical data

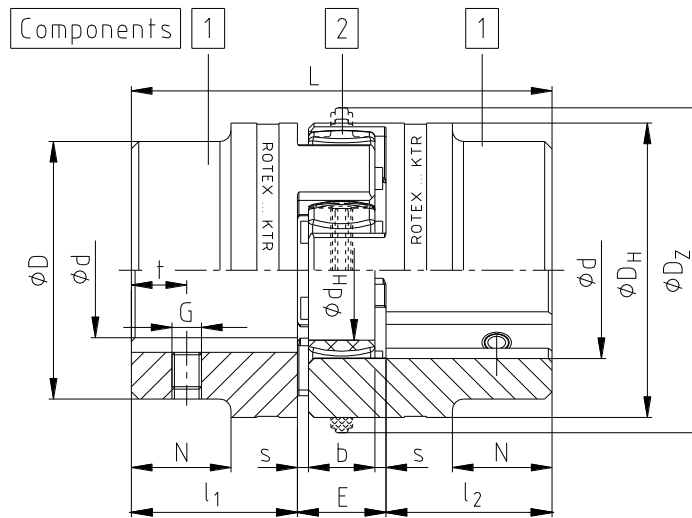

Illustration 3: ROTEX® (material: steel)

Table 5: Material steel

Size	Component	Spider ¹⁾ (component 2) Rated torque [Nm]			Finish bore ²⁾ d (min-max)	Dimensions [mm] ³⁾										
		92 ShA	98 ShA	64 ShD		General										
						L	l ₁ , l ₂	E	b	s	D _H	D _Z	D _{Z1} ⁴⁾	d _H	D	N
14	1a	7.5	12.5	16	0 - 16	35	11	13	10	1.5	30	-	-	10	30	-
	1b					50	18.5									
19	1a	10	17	21	0 - 25	66	25	16	12	2.0	40	-	-	18	40	-
	1b					90	37									
24	1a	35	60	75	0 - 35	78	30	18	14	2.0	55	-	-	27	55	-
	1b					118	50									
28	1a	95	160	200	0 - 40	90	35	20	15	2.5	65	-	-	30	65	-
	1b					140	60									
38	1	190	325	405	0 - 48	114	45	24	18	3.0	80	-	-	38	70	27
	1b					164	70								80	-
42	1	265	450	560	0 - 55	126	50	26	20	3.0	95	-	-	46	85	28
	1b					176	75								95	-
48	1	310	525	655	0 - 62	140	56	28	21	3.5	105	-	-	51	95	32
	1b					188	80								105	-
55	1	410	685	825	0 - 75	160	65	30	22	4.0	120	-	-	60	110	37
	1b					210	90								120	-
65	1	625	940	1175	0 - 80	185	75	35	26	4.5	135	-	-	68	115	47
	1b					235	100								135	-
75	1	1280	1920	2400	0 - 95	210	85	40	30	5.0	160	-	-	80	135	53
	1b					260	110								160	-
90	1	2400	3600	4500	0 - 110	245	100	45	34	5.5	200	218	230	100	160	62
	1b					295	125								200	-
100	1	3300	4950	6185	0 - 115	270	110	50	38	6.0	225	246	260	113	180	89
110	1	4800	7200	9000	0 - 125	295	120	55	42	6.5	255	276	290	127	200	96
125	1	6650	10000	12500	60 - 145	340	140	60	46	7.0	290	315	330	147	230	112
140	1	8550	12800	16000	60 - 160	375	155	65	50	7.5	320	345	360	165	255	124
160	1	12800	19200	24000	80 - 185	425	175	75	57	9.0	370	400	415	190	290	140
180	1	18650	28000	35000	85 - 200	475	195	85	64	10.5	420	450	465	220	325	156

- 1) Maximum torque of the coupling $T_{Kmax.}$ = rated torque of the coupling $T_{K rated} \times 2$
- 2) Bores H7 with keyway to DIN 6885 sheet 1 [JS9] and setscrew
- 3) For dimensions G and t see table 8; there is a setscrew on the keyway
- 4) D_{Z1} = internal diameter of housing



1 Technical data

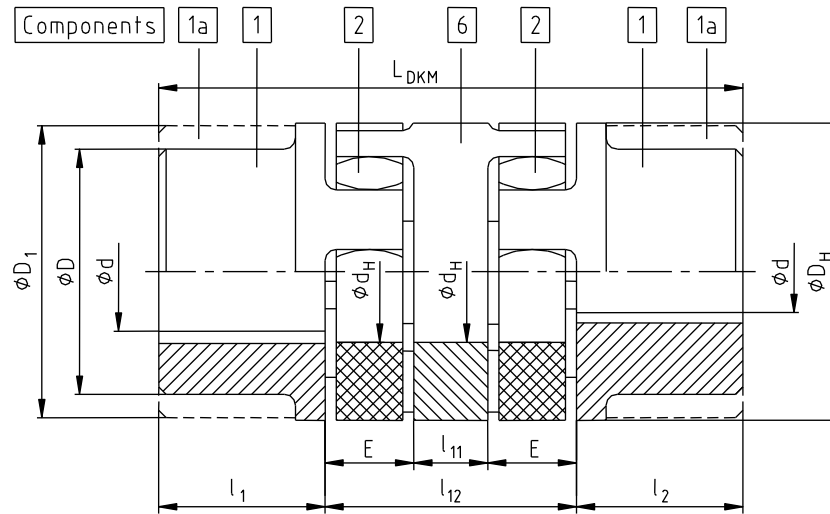

Illustration 4: ROTEX® type DKM

Table 6: Type DKM ⁵⁾

Size	Spider ¹⁾ (component 2) Rated torque [Nm]		Dimensions [mm] ³⁾										
	92 ShA	98 ShA	Dimensions d, D, D ₁	General								l ₁₁	l ₁₂
				L _{DKM}	l ₁ , l ₂	E	b	s	D _H	d _H			
19	10	17	see table 1 to 5	92	25	16	12	2.0	40	18	10	42	
24	35	60		112	30	18	14	2.0	55	27	16	52	
28	95	160		128	35	20	15	2.5	65	30	18	58	
38	190	325		158	45	24	18	3.0	80	38	20	68	
42	265	450		174	50	26	20	3.0	95	46	22	74	
48	310	525		192	56	28	21	3.5	105	51	24	80	
55	410	685		218	65	30	22	4.0	120	60	28	88	
65	625	940		252	75	35	26	4.5	135	68	32	102	
75	1280	1920		286	85	40	30	5.0	160	80	36	116	
90	2400	3600		330	100	45	34	5.5	200	100	40	130	

- 1) Maximum torque of the coupling $T_{Kmax.} = \text{rated torque of the coupling } T_{Krated} \times 2$
- 2) Bores H7 with keyway to DIN 6885 sheet 1 [JS9] and setscrew
- 3) For dimensions G and t see table 8; there is a setscrew on the keyway (only with AI-D opposite the keyway)



1 Technical data

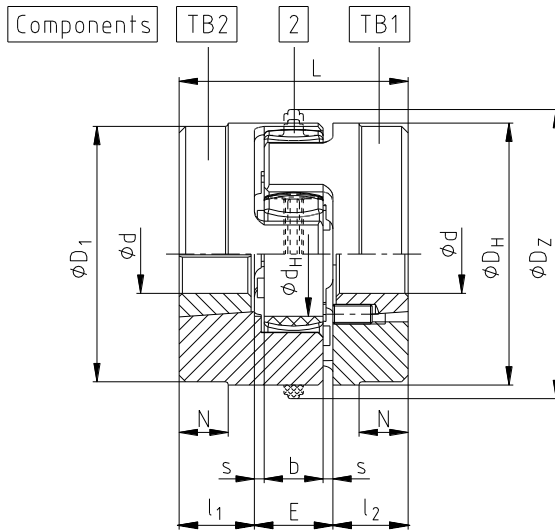

Illustration 5: ROTEX® type with taper clamping sleeve

Coupling design:

- TB1 Screwing on cam side
- TB2 Screwing on collar side

Different combinations of types TB1 and TB2 are possible.

Table 7: Type with taper clamping sleeve

Size	Component	Spider ¹⁾ (component 2)		Finish bore d (min-max)	Dimensions [mm]											Taper clamping sleeve
		Rated torque [Nm]			General											
		92 ShA	98 ShA		L	l ₁ , l ₂	E	b	s	D _H	D _Z	D _{Z1} ²⁾	d _H	D ₁	N	
24	1a	35	60	10 - 25	64	23	18	14	2.0	55	-	-	27	-	-	1008
28	1a	95	160	10 - 25	66	23	20	15	2.5	65	-	-	30	-	-	1108
38	1a	190	325	10 - 25	70	23	24	18	3.0	80	-	-	38	78	15	1108
42	1a	265	450	14 - 25	78	26	26	20	3.0	95	-	-	46	94	16	1610
48	1a	310	525	14 - 40	106	39	28	21	3.5	105	-	-	51	104	28	1615
55	1a	410	685	14 - 50	96	33	30	22	4.0	120	-	-	60	118	20	2012
65	1	625	940	14 - 50	101	33	35	26	4.5	135	-	-	68	115	5	2012
75	1	1280	1920	16 - 60	144	52	40	30	5.0	160	-	-	80	158	36	2517
				25 - 75												3020 ³⁾
90	1	2400	3600	25 - 75	149	52	45	34	5.5	200	218	230	100	160	14	3020
100	1	3300	4950	35 - 90	230	90	50	38	6.0	225	246	260	113	180	69	3535
125	1	6650	10000	55 - 110	288	114	60	46	7.0	290	315	330	147	230	86	4545

1) Maximum torque of the coupling $T_{Kmax.} = \text{rated torque of the coupling } T_{K \text{ rated}} \times 2$
 2) D_{Z1} = internal diameter of housing
 3) Available for type TB2 only



ROTEX® couplings with attachments that can generate heat, sparks and static charging (e. g. combinations with brake drums, brake disks, overload systems such as torque limiters, fan impellers etc.) are not permitted for the use in potentially explosive atmospheres.
A separate analysis must be performed.

2 Advice

2.1 General advice

Please read through these operating/assembly instructions carefully before you start up the coupling. Please pay special attention to the safety instructions!



The **ROTEX®** coupling is suitable and approved for the use in potentially explosive atmospheres. When using the coupling in potentially explosive atmospheres, observe the special advice and instructions regarding safety in enclosure A.

The operating/assembly instructions are part of your product. Please store them carefully and close to the coupling. The copyright for these operating/assembly instructions remains with KTR.

Please observe protection note ISO 16016.	Drawn:	2019-07-02 Pz/Wb	Replacing:	KTR-N dated 2017-09-06
	Verified:	2019-07-23 Pz	Replaced by:	

2 Advice

2.2 Safety and advice symbols



Warning of potentially explosive atmospheres

This symbol indicates notes which may contribute to preventing bodily injuries or serious bodily injuries that may result in death caused by explosion.



Warning of personal injury

This symbol indicates notes which may contribute to preventing bodily injuries or serious bodily injuries that may result in death.



Warning of product damages

This symbol indicates notes which may contribute to preventing material or machine damage.



General advice

This symbol indicates notes which may contribute to preventing adverse results or conditions.



Warning of hot surfaces

This symbol indicates notes which may contribute to preventing burns with hot surfaces resulting in light to serious bodily injuries.

2.3 General hazard warnings



With assembly, operation and maintenance of the coupling it has to be made sure that the entire drive train is secured against accidental switch-on. You may be seriously hurt by rotating parts. Please make absolutely sure to read through and observe the following safety indications.

- All operations on and with the coupling have to be performed taking into account "safety first".
- Please make sure to switch off the power pack before you perform your work on the coupling.
- Secure the power pack against accidental switch-on, e. g. by providing warning signs at the place of switch-on or removing the fuse for current supply.
- Do not reach into the operating area of the coupling as long as it is in operation.
- Please secure the coupling against accidental contact. Please provide for the necessary protection devices and covers.

2.4 Intended use

You may only assemble, operate and maintain the coupling if you

- have carefully read through the operating/assembly instructions and understood them
- are technically qualified and specifically trained (e. g. safety, environment, logistics)
- are authorized by your company

The coupling may only be used in accordance with the technical data (see chapter 1). Unauthorized modifications on the coupling design are not admissible. We will not assume liability for any damage that may arise. In the interest of further development we reserve the right for technical modifications.

The **ROTEX®** described in here corresponds to the technical status at the time of printing of these operating/assembly instructions.

**2 Advice****2.5 Coupling selection**

For a permanent and failure-free operation of the coupling it must be selected according to the selection instructions (according to DIN 740 part 2) for the particular application (see catalogue drive technology "ROTEX®").

If the operating conditions (performance, speed, modifications on engine and machine) change, the coupling selection must imperatively be reviewed.

Please make sure that the technical data regarding torque refer to the spider only. The transmittable torque of the shaft-hub-connection must be reviewed by the customer and is subject to his responsibility.

For drives subject to torsional vibrations (drives with cyclic stress due to torsional vibrations) it is necessary to perform a torsional vibration calculation to ensure a reliable selection. Typical drives subject to torsional vibrations are e. g. drives with diesel engines, piston pumps, piston compressors etc. If requested, KTR will perform the coupling selection and the torsional vibration calculation.

2.6 Reference to EC Machinery Directive 2006/42/EC

The couplings supplied by KTR should be considered as components, not machines or partly completed machines according to EC Machinery Directive 2006/42/EC. Consequently KTR does not have to issue a declaration of incorporation. For details about safe assembly, start-up and safe operation refer to the present operating/assembly instructions considering the warnings.

3 Storage, transport and packaging**3.1 Storage**

The coupling hubs are supplied in preserved condition and can be stored at a dry and roofed place for 6 - 9 months.

The features of the coupling spiders (elastomers) remain unchanged for up to 5 years with favourable storage conditions.



The storage rooms must not include any ozone-generating devices like e. g. fluorescent light sources, mercury-vapour lamps or electrical high-voltage appliances.

Humid storage rooms are not suitable.

Please make sure that condensation is not generated. The best relative air humidity is less than 65 %.

3.2 Transport and packaging

In order to avoid any injuries and any kind of damage always make use of proper transport and lifting equipment.

The couplings are packed differently each depending on size, number and kind of transport. Unless otherwise contractually agreed, packaging will follow the in-house packaging specifications of KTR.



4 Assembly

The coupling is generally supplied in individual parts. Before assembly the coupling has to be inspected for completeness.

4.1 Components of the coupling

Components of ROTEX®, shaft coupling type No. 001

Component	Number	Description
1	2	Hub
2	1	Spider ¹⁾
3	5 ²⁾	DZ elements ¹⁾
4	2	Setscrews DIN EN ISO 4029

- 1) Optionally spider or DZ elements
- 2) With size 180 the number is 6.

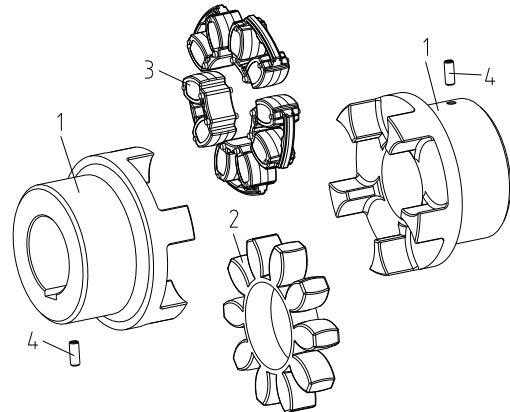

Illustration 6: ROTEX®

Components of ROTEX® type DKM ¹⁾

Component	Number	Description
1	2	Hub
2	2	Spider
3	1	DKM spacer
4	2	Setscrews DIN EN ISO 4029

- 1) Type DKM not available with DZ elements.

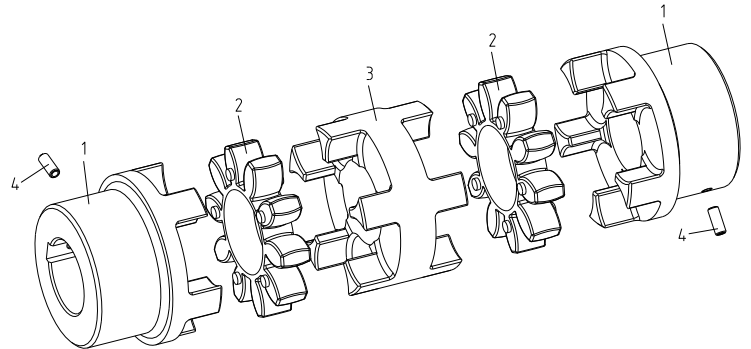

Illustration 7: ROTEX® type DKM

Components of ROTEX® type with taper clamping sleeve

Component	Number	Description
TB1/TB2	2	Hub for taper clamping sleeve
1	2	Taper clamping sleeve
2	1	Spider ¹⁾
3	5 ²⁾	DZ elements ¹⁾
4	4	Setscrews DIN EN ISO 4029

- 1) Optionally spider or DZ elements
- 2) With size 180 the number is 6.

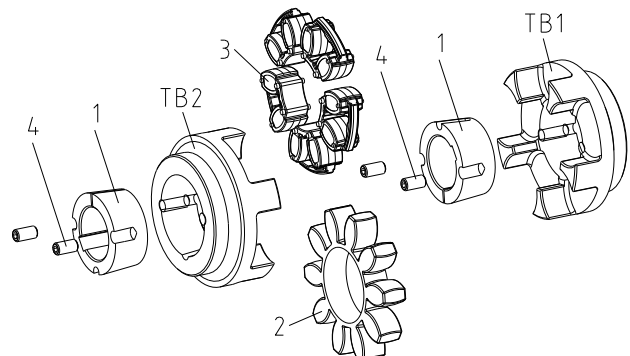

Illustration 8: ROTEX® type with taper clamping sleeve







Please observe protection note ISO 16016.	Drawn:	2019-07-02 Pz/Wb	Replacing:	KTR-N dated 2017-09-06
	Verified:	2019-07-23 Pz	Replaced by:	



4 Assembly

4.1 Components of the coupling

Features of standard spiders

Spider hardness (Shore)	92 Shore A		98 Shore A		64 Shore D	
	T-PUR® (orange)	PUR (yellow)	T-PUR® (purple)	PUR (red)	T-PUR® (light green)	PUR (natural white ¹⁾)
Marking (colour)						

1) Natural white with green marking of teeth

4.2 Advice for finish bore



The maximum permissible bore diameters d (see chapter 1 - technical data) must not be exceeded. If these figures are disregarded, the coupling may tear. Rotating particles may cause danger to life.

- Hub bores machined by the customer have to observe concentricity or axial runout, respectively (see illustration 9).
- Make absolutely sure to observe the figures for $\varnothing d_{max}$.
- Carefully align the hubs when the finish bores are drilled.
- Provide for a setscrew according to DIN EN ISO 4029 with a cup point or an end plate to fasten the hubs axially.

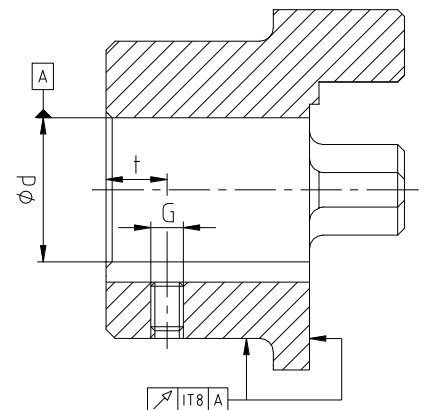

Illustration 9: Concentricity and axial run-out



The customer bears the sole responsibility for all machining processes performed subsequently on unbored or pilot bored as well as finish machined coupling components and spare parts. KTR does not assume any warranty claims resulting from insufficient remachining.



KTR supplies unbored or pilot bored coupling components and spare parts only upon explicit request of the customer. These parts are additionally marked with the symbol Ⓢ .

Reference to unbored resp. pilot bored coupling components with explosion protection marking:

Basically the company KTR supplies couplings resp. coupling hubs with explosion protection marking as an unbored or pilot bored type only on explicit request of the customer. The prerequisite is a declaration of exemption submitted by the customer assuming any responsibility and liability for remachining performed properly.

Table 8: Setscrew DIN EN ISO 4029

Size	14	19	24	28	38	42	48	55	65	75	90	100	110	125	140	160	180
Dimension G	M4	M5	M5	M8	M8	M8	M8	M10	M10	M10	M12	M12	M16	M16	M20	M20	M20
Dimension t	5	10	10	15	15	20	20	20	20	25	30	30	35	40	45	50	50
Tightening torque T_A [Nm]	1.5	2	2	10	10	10	10	17	17	17	40	40	80	80	140	140	140

**4 Assembly****4.2 Advice for finish bore****Table 9: Recommended fit pairs acc. to DIN 748-1**

Bore [mm]		Shaft tolerance	Bore tolerance
above	up to		
	50	k6	H7
50		m6	(KTR standard)

If a feather keyway is intended to be used in the hub, it should correspond to the tolerance ISO JS9 (KTR standard) with standard operating conditions or ISO P9 with complicated operating conditions (frequently alternating torsional direction, shock loads, etc.). The keyway should preferably be located between the cams. With axial fastening via setscrew the tapped hole should be positioned on the keyway except for AI-D which should be positioned opposite the keyway.

The transmittable torque of the shaft-hub-connection must be reviewed by the customer and is subject to his responsibility.

4.3 Assembly of the hubs

We recommend to inspect bores, shaft, keyway and feather key for dimensional accuracy before assembly.



Heating the hubs lightly (approx. 80 °C) allows for an easier mounting on the shaft.



Please pay attention to the ignition risk in potentially explosive atmospheres!



Touching the heated hubs causes burns. Please wear safety gloves.



With the assembly make sure that the distance dimension E (see table 1 to 7) is observed to allow for axial clearance of the spider when in operation. Disregarding this advice may cause damage to the coupling.



If used in potentially explosive atmospheres the setscrews to fasten the hubs as well as all screw connections must be secured against working loose additionally, e. g. conglomerating with Loctite (average strength).

- Mount the hubs on the shaft of driving and driven side (see illustration 10).
- Insert the spider or DZ elements into the cam section of the hub on the driving or driven side.
- Shift the power packs in axial direction until the distance dimension E is achieved (see illustration 11).
- If the power packs are already firmly assembled, shifting the hubs axially on the shafts allows for setting the distance dimension E.
- Fasten the hubs by tightening the setscrews DIN EN ISO 4029 with a cup point (tightening torques see table 8).



If the shaft diameters with inserted feather key are smaller than dimension d_H (see table 1 to 7) of the spider, one or two shaft ends may protude into the spider.



4 Assembly
4.3 Assembly of the hubs

Illustration 10: Assembly of the hubs

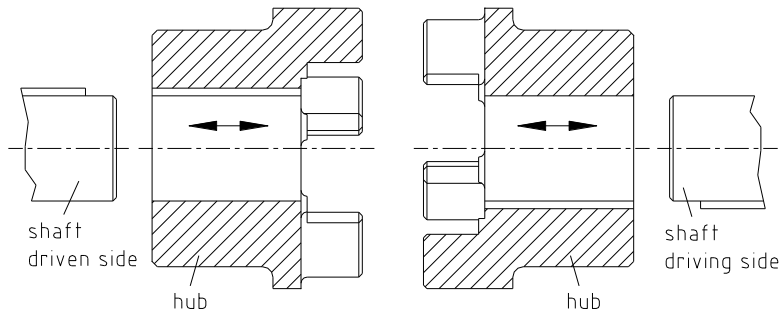
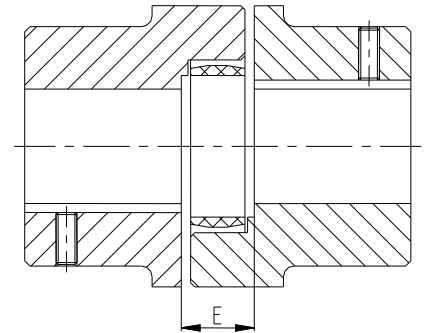

Illustration 11: Assembly of coupling

4.4 Assembly of taper clamping sleeve
Assembly of taper clamping sleeve:

Clean the contact surfaces of the taper clamping sleeves and of shaft and hub and afterwards apply thin fluid oil lightly (e. g. Ballistol Universal oil or Klüber Quietsch-Ex).

The taper clamping sleeves have got axially parallel, cylindrical and smooth tapped blind holes. Only half of these holes are located in the material of the sleeve. The other half located in the hub has got threads.

Fit the coupling element and the taper clamping sleeve into each other, make sure that the bores cover each other and tighten the setscrews lightly. Fit the coupling element along with the taper clamping sleeve on the shaft and tighten the setscrews at the tightening torque specified in table 10.

During the screwing operation the hub is mounted onto the taper sleeve and thus the sleeve is pressed onto the shaft. By light blows of the hammer the taper clamping sleeve must be pushed further into the taper bore by means of a suitable sleeve. Afterwards re-tighten the setscrews at the tightening torque specified in table 10. This process must be performed at least once.

After operation under load of the drive for a short while please inspect if the setscrews have unscrewed.

Axial fixing of the Taper Lock hub (coupling hub with taper clamping sleeve) is obtained by proper assembly only.



If used in potentially explosive atmospheres the setscrews to fasten the taper clamping sleeves have to be secured against working loose additionally, e. g. conglomerating with Loctite (average strength).



Taper clamping sleeves used without a feather key are not permitted in potentially explosive atmospheres and are thus not provided with a respective explosion protection marking.



Oils and greases with molybdenum disulphide or high-pressure additives, additives of Teflon and silicone as well as internal lubricants reducing the coefficient of friction significantly must not be used.

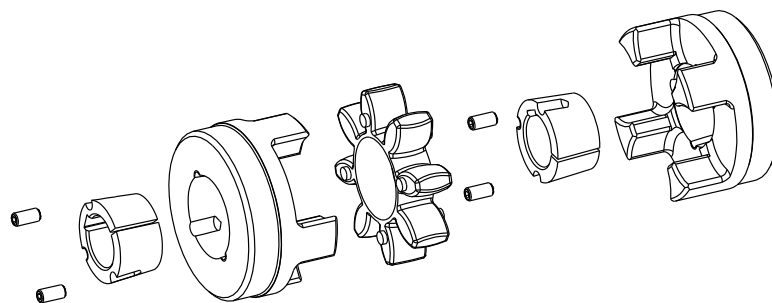

Illustration 12: ROTEX® type with taper clamping sleeve



4 Assembly

4.4 Assembly of taper clamping sleeve

Disassembly of taper clamping sleeve:

The taper clamping sleeve is released by removing the setscrews. Afterwards one of the setscrews used as forcing screw is screwed in the thread of the sleeve and tightened. The coupling hub untightened that way can be manually removed from the shaft with the taper clamping sleeve.

Table 10:

Taper clamping sleeve	Screw dimensions				Number
	G [inch]	L [inch]	SW [mm]	T _A [Nm]	
1008	1/4	1/2	3	5.7	2
1108	1/4	1/2	3	5.7	2
1610	3/8	5/8	5	20	2
1615	3/8	5/8	5	20	2
2012	7/16	7/8	6	31	2
2517	1/2	7/8	6	49	2
3020	5/8	1 1/4	8	92	2
3535	1/2	1 1/2	10	115	3
4545	3/4	1 3/4	12	170	3

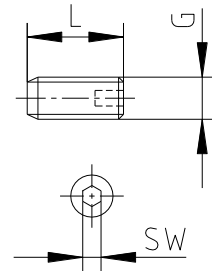

Illustration 13: Withworth setscrew (BSW)

4.5 Displacements - alignment of the couplings

The displacement figures specified in tables 11 to 13 provide for sufficient safety to compensate for external influences like, for example, heat expansion or foundation settling.



In order to ensure a long service life of the coupling and avoid risks with the use in potentially explosive atmospheres, the shaft ends must be accurately aligned. Please absolutely observe the displacement figures indicated (see table 11 to 13). If the figures are exceeded, the coupling will be damaged. The more accurate the alignment of the coupling, the longer is its service life. If used in potentially explosive atmospheres for explosion group IIC, only half of the displacement figures (see table 11 to 13) are permissible.

Please note:

- The displacement figures specified in table 11 to 13 are maximum figures which must not arise in parallel. If radial and angular displacements arise at the same time, the permissible displacement values may only be used proportionally (see illustration 15).
- Please inspect with a dial gauge, ruler or feeler whether the permissible displacement figures of tables 11 to 13 can be observed.

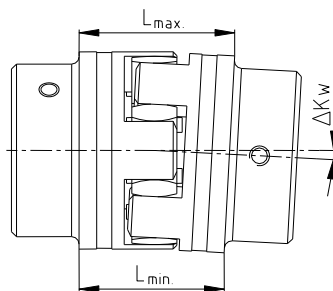

Angular displacements

$\Delta K_w = L_{1max} - L_{1min} \text{ [mm]}$

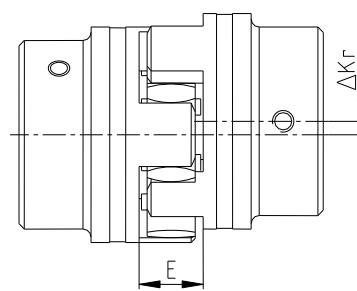

Radial displacements

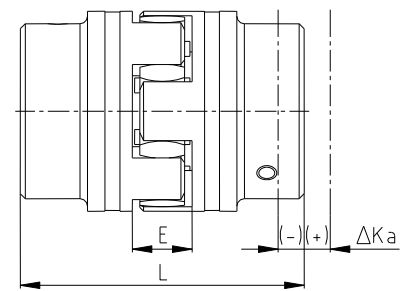

Axial displacements

$L_{max} = L + \Delta K_a \text{ [mm]}$

Illustration 14: Displacements

Please observe protection note ISO 16016.	Drawn: 2019-07-02 Pz/Wb	Replacing: KTR-N dated 2017-09-06
	Verified: 2019-07-23 Pz	Replaced by:

4 Assembly

4.5 Displacements - alignment of the couplings

Examples of the displacement combinations specified in illustration 15:

Example 1:
 $\Delta K_r = 30\%$
 $\Delta K_w = 70\%$

Example 2:
 $\Delta K_r = 60\%$
 $\Delta K_w = 40\%$

Illustration 15:
Combinations of displacement

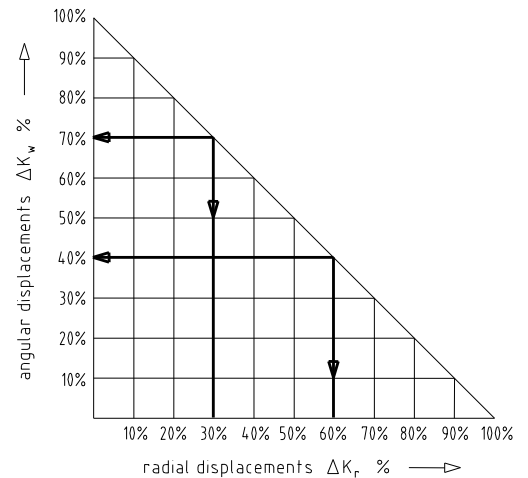

$$\Delta K_{\text{total}} = \Delta K_r + \Delta K_w \leq 100\%$$

Table 11: Displacement figures for 92 and 98 Shore A

Size	14	19	24	28	38	42	48	55	65	75	90	100	110	125	140	160	180	
Max. axial displacement ΔK_a [mm]	-0.5	-0.5	-0.5	-0.7	-0.7	-1.0	-1.0	-1.0	-1.0	-1.5	-1.5	-1.5	-2.0	-2.0	-2.0	-2.5	-3.0	
	+1.0	+1.2	+1.4	+1.5	+1.8	+2.0	+2.1	+2.2	+2.6	+3.0	+3.4	+3.8	+4.2	+4.6	+5.0	+5.7	+6.4	
Max. radial displacement ΔK_r [mm] with	1500 rpm	0.17	0.20	0.22	0.25	0.28	0.32	0.36	0.38	0.42	0.48	0.50	0.52	0.55	0.60	0.62	0.64	0.68
	3000 rpm	0.11	0.13	0.15	0.17	0.19	0.21	0.25	0.26	0.28	0.32	0.34	0.36	0.38	-	-	-	-
ΔK_w [degree] max. angular displacement with n=1500 rpm ΔK_w [mm]	1.2	1.2	0.9	0.9	1.0	1.0	1.1	1.1	1.2	1.2	1.2	1.2	1.3	1.3	1.2	1.2	1.2	
	0.67	0.82	0.85	1.05	1.35	1.70	2.00	2.30	2.70	3.30	4.30	4.80	5.60	6.50	6.60	7.60	9.00	
ΔK_w [degree] max. angular displacement with n=3000 rpm ΔK_w [mm]	1.1	1.1	0.8	0.8	0.9	0.9	1.0	1.0	1.1	1.1	1.1	1.1	1.2	-	-	-	-	
	0.60	0.70	0.75	0.85	1.10	1.40	1.60	2.00	2.30	2.90	3.80	4.20	5.00	-	-	-	-	

Table 12: Displacement figures for 64 Shore D

Size	14	19	24	28	38	42	48	55	65	75	90	100	110	125	140	160	180	
Max. axial displacement ΔK_a [mm]	-0.5	-0.5	-0.5	-0.7	-0.7	-1.0	-1.0	-1.0	-1.0	-1.5	-1.5	-1.5	-2.0	-2.0	-2.0	-2.5	-3.0	
	+1.0	+1.2	+1.4	+1.5	+1.8	+2.0	+2.1	+2.2	+2.6	+3.0	+3.4	+3.8	+4.2	+4.6	+5.0	+5.7	+6.4	
Max. radial displacement ΔK_r [mm] with	1500 rpm	0.11	0.13	0.15	0.18	0.21	0.23	0.25	0.27	0.30	0.34	0.36	0.37	0.40	0.43	0.45	0.46	0.49
	3000 rpm	0.08	0.09	0.10	0.13	0.15	0.16	0.18	0.19	0.21	0.24	0.25	0.26	0.28	-	-	-	-
ΔK_w [degree] max. angular displacement with n=1500 rpm ΔK_w [mm]	1.1	1.1	0.8	0.8	0.9	0.9	1.0	1.0	1.1	1.1	1.1	1.1	1.2	1.2	1.1	1.1	1.1	
	0.57	0.77	0.77	0.90	1.25	1.40	1.80	2.00	2.50	3.00	3.80	4.30	5.30	6.00	6.10	7.10	8.00	
ΔK_w [degree] max. angular displacement with n=3000 rpm ΔK_w [mm]	1.0	1.0	0.7	0.7	0.8	0.8	0.9	0.9	1.0	1.0	1.0	1.0	1.1	-	-	-	-	
	0.52	0.70	0.67	0.80	1.00	1.30	1.60	1.80	2.20	2.70	3.50	4.00	4.90	-	-	-	-	

Table 13: Displacement figures for type DKM only

Size	19	24	28	38	42	48	55	65	75	90	
Max. axial displacement ΔK_a [mm]	+1.2	+1.4	+1.5	+1.8	+2.0	+2.1	+2.2	+2.6	+3.0	+3.4	
	-1.0	-1.0	-1.4	-1.4	-2.0	-2.0	-2.0	-2.0	-3.0	-3.0	
Max. radial displacement ΔK_r [mm] with n =	1500 rpm	0.45	0.59	0.66	0.77	0.84	0.91	1.01	1.17	1.33	1.48
	3000 rpm	0.40	0.53	0.60	0.70	0.75	0.82	0.81	1.05	1.19	1.33
ΔK_w [degree] max. angular displacement with n =	1500 rpm	1.0	1.0	1.0	1.0	1.0	1.0	1.0	1.0	1.0	
	3000 rpm	0.9	0.9	0.9	0.9	0.9	0.9	0.9	0.9	0.9	

Please observe protection note ISO 16016.

Drawn: 2019-07-02 Pz/Wb
Verified: 2019-07-23 Pz

Replacing: KTR-N dated 2017-09-06
Replaced by:

	ROTEX® Operating/Assembly instructions	KTR-N 40210 EN Sheet: 16 of 27 Edition: 23
--	---	--

5 Start-up

Before start-up of the coupling, inspect the tightening of setscrews in the hubs, the alignment and the distance dimension E and adjust, if necessary, and also inspect all screw connections for the tightening torques specified.



If used in potentially explosive atmospheres the setscrews to fasten the hubs as well as all screw connections must be secured against working loose additionally, e. g. conglomerating with Loctite (average strength).

Finally the coupling protection against accidental contact must be fitted. It is required in accordance with DIN EN ISO 12100 (Safety of Machinery) and directive 2014/34/EU and must protect against

- access with the little finger
- falling down of solid foreign objects.

The cover may provide for openings intended for necessary heat dissipation. These openings have to comply with DIN EN ISO 13857.

The cover must be electrically conductive and included in the equipotential bonding. Bellhousings (magnesium share below 7.5 %) made of aluminium and damping rings (NBR) can be used as connecting element between pump and electric motor. The cover may only be taken off with standstill of the unit.



If the couplings are used in locations subject to dust explosion and in mining the user must make sure that there is no accumulation of dust in a dangerous volume between the cover and the coupling. The coupling must not operate in an accumulation of dust.

For covers with unlocked openings on the top face no light metals must be used if the couplings are used as equipment of equipment group II (*if possible, made of stainless steel*).

If the couplings are used in mining (equipment group I M2), the cover must not be made of light metal. In addition, it must be resistant to higher mechanical loads than with use as equipment of equipment group II.

During operation of the coupling, please pay attention to

- different operating noise
- vibrations occurring.



If you note any irregularities with the coupling during operation, the drive unit must be switched off immediately. The cause of the breakdown must be specified by means of the table „Breakdowns“ and, if possible, be eliminated according to the proposals. The potential breakdowns specified can be hints only. To find out the cause all operating factors and machine components must be considered.

Coating of coupling:



If coated (priming, paintings, etc.) couplings are used in potentially explosive atmospheres, the requirements on conductivity and coating thickness must be considered. With paintings up to 200 µm electrostatic load does not have to be expected. Paintings and coatings exceeding a thickness of 200 µm are generally impermissible for potentially explosive atmospheres. This also applies for multiple coatings exceeding an overall thickness of 200 µm. Make sure with painting or coating that the coupling components are conductively connected with the device/devices to be connected so that the equipotential bonding is not impeded by the paint or coat applied. In addition, make sure that the marking of the coupling remains legible. Painting or coating of the spider is generally not admitted.

Please observe protection note ISO 16016.	Drawn: 2019-07-02 Pz/Wb Verified: 2019-07-23 Pz	Replacing: KTR-N dated 2017-09-06 Replaced by:
---	--	---



6 Breakdowns, causes and elimination

The below-mentioned failures can lead to a use of the **ROTEX®** coupling other than intended. In addition to the specifications given in these operating/assembly instructions make sure to avoid such failures.

The errors listed can only be clues to search for the failures. When searching for the failure the adjacent components must generally be considered.



If used other than intended the coupling can become a source of ignition.
EU directive 2014/34/EU requires special care by the manufacturer and the user.

General failures with use other than intended:

- Important data for the coupling selection are not forwarded.
- The calculation of the shaft-hub-connection is not considered.
- Coupling components with damage occurred during transport are assembled.
- If the heated hubs are assembled, the permissible temperature is exceeded.
- The clearance of the components to be assembled is not coordinated with one another.
- Tightening torques have been fallen below/exceeded.
- Components are mixed up by mistake/assembled incorrectly.
- A wrong or no spider/DZ elements are inserted in the coupling.
- No original **KTR** components (purchased parts) are used.
- Old/ spiders/DZ elements already worn off or spiders/DZ elements stored for too long are used.
- Maintenance intervals are not observed.

Breakdowns	Causes	Hazard notes for potentially explosive atmospheres	Elimination
Different operating noise and/or vibrations occurring	Misalignment	Increased temperature on the spider surface; ignition risk by hot surfaces	1) Set the unit out of operation 2) Eliminate the reason for the misalignment (e. g. loose foundation bolts, breaking of the engine mount, heat expansion of unit components, modification of the installation dimension E of the coupling) 3) For inspection of wear see chapter 10.2
	Wear of spider, short-term torque transmission due to metal contact	Ignition risk due to sparking	1) Set the unit out of operation 2) Disassemble the coupling and remove residues of the spider 3) Inspect coupling components and replace coupling components that have been damaged 4) Insert spider, assemble coupling components 5) Inspect alignment, adjust if necessary
	Screws for axial fastening of hubs working loose	Ignition risk due to hot surfaces and sparking	1) Set the unit out of operation 2) Inspect alignment of coupling 3) Tighten the screws to fasten the hubs and secure against working loose 4) For inspection of wear see chapter 10.2
Breaking of cams	Wear of spider, torque transmission due to metal contact	Ignition risk due to sparking	1) Set the unit out of operation 2) Replace complete coupling 3) Inspect alignment
	Breaking of the cams due to high impact energy/overload		1) Set the unit out of operation 2) Replace complete coupling 3) Inspect alignment 4) Find out the reason for overload

**6 Breakdowns, causes and elimination**

Breakdowns	Causes	Hazard notes for potentially explosive atmospheres	Elimination
Breaking of cams	Operating parameters do not meet with the performance of the coupling	Ignition risk due to sparking	1) Set the unit out of operation 2) Review the operating parameters and select a bigger coupling (consider mounting space) 3) Assemble new coupling size 4) Inspect alignment
	Operating error of the unit		1) Set the unit out of operation 2) Replace complete coupling 3) Inspect alignment 4) Instruct and train the service staff
Early wear of spider	Misalignment	Increased temperature on the spider surface; ignition risk by hot surfaces	1) Set the unit out of operation 2) Eliminate the reason for the misalignment (e. g. loose foundation bolts, breaking of the engine mount, heat expansion of unit components, modification of the installation dimension E of the coupling) 3) For inspection of wear see chapter 10.2
	e. g. contact with aggressive liquids/oils, ozone influence, too high/low ambient temperatures etc. causing physical modification of the spider	Ignition risk due to sparking with metallic contact of the cams	1) Set the unit out of operation 2) Disassemble the coupling and remove residues of the spider 3) Inspect coupling components and replace coupling components that have been damaged 4) Insert spider, assemble coupling components 5) Inspect alignment, adjust if necessary 6) Make sure that further physical modifications of the spider are excluded
	Ambient/contact temperatures which are too high for the spider, max. permissible -30 °C/+90 °C		1) Set the unit out of operation 2) Disassemble the coupling and remove residues of the spider 3) Inspect coupling components and replace coupling components that have been damaged 4) Insert spider, assemble coupling components 5) Inspect alignment, adjust if necessary 6) Inspect and adjust ambient/contact temperature (correct by using other spider materials, if necessary)
Early wear of spider (liquefaction of material inside the spider cam)	Vibrations of drive		1) Set the unit out of operation 2) Disassemble the coupling and remove residues of the spider 3) Inspect coupling components and replace coupling components that have been damaged 4) Insert spider, assemble coupling components 5) Inspect alignment, adjust if necessary 6) Find out the reason for the vibrations (correct by spider with lower or higher Shore hardness, if necessary)



When operating with a worn spider (see chapter 10.3) proper operation is not ensured.



7 Disposal

In respect of environmental protection we would ask you to dispose of the packaging resp. products on termination of their service life in accordance with the legal regulations and standards that apply.

- **Metal**
Any metal components have to be cleaned and disposed of by scrap metal.
- **Nylon materials**
Nylon materials have to be collected and disposed of by a waste disposal company.

8 Maintenance and service

ROTEX® is a low-maintenance coupling. We recommend to perform a visual inspection on the coupling **at least once a year**. Please pay special attention to the condition of the coupling spiders.

- Since the flexible machine bearings of the driving and driven side settle during the course of load, inspect the alignment of the coupling and re-align the coupling, if necessary.
- The coupling components have to be inspected for damages.
- The screw connections have to be visually inspected.



Having started up the coupling the tightening torques of the screws have to be inspected during the usual inspection intervals.



With the use in potentially explosive atmospheres observe chapter 10.2 "Inspection intervals for couplings in  potentially explosive atmospheres".

9 Spares inventory, customer service addresses

We recommend to store major spare parts on site to ensure the readiness for use of the machine in case if a coupling fails.

Contact addresses of the KTR partners for spare parts and orders can be obtained from the KTR homepage at www.ktr.com.



KTR does not assume any liability or warranty for the use of spare parts and accessories which are not provided by KTR and for the damages which may incur as a result.

Please observe protection note ISO 16016.	Drawn: 2019-07-02 Pz/Wb	Replacing: KTR-N dated 2017-09-06
	Verified: 2019-07-23 Pz	Replaced by:



10 Enclosure A

Advice and instructions regarding the use in  potentially explosive atmospheres

Applicable hub designs/types:

a) Hubs that may be used in group II, category 2 and 3 :

(hubs with feather keyway and hubs with CLAMPEX® clamping set or clamping ring hubs)

- 1.0 Hub with feather keyway and setscrew
- 1.3 Hub with spline
- 1.4 Hub with feather keyway, without setscrew
- 2.1 Clamping hub single slot with feather keyway
- 2.3 Clamping hub single slot with spline
- 2.6 Clamping hub double slot with feather keyway
- 4.0 Hub with CLAMPEX® clamping set KTR 150
- 4.1 Hub with CLAMPEX® clamping set KTR 200
- 4.2 Hub with CLAMPEX® clamping set KTR 250
- 4.3 Hub with CLAMPEX® clamping set KTR 400
- 4.4 Hub with CLAMPEX® clamping set KTR 401
- 6.0 Clamping ring hub
- 6.5 Clamping ring hub (hub type as 6.0, but external clamping screws only)
- 7.6 Half shell hub (DH) with feather keyway
- 7.9 Half shell hub (H) with feather keyway
- Type standard, AFN, BFN, CF, CFN, DF, DFN, DKM, ZS-DKM, ZS-DKM-H, SP and TB with hubs corresponding to the specifications above

b) Hubs which may be used in group II, category 3 only: hubs without feather keyway

- 2.0 Clamping hub single slot without feather keyway
- 2.5 Clamping hub double slot without feather keyway
- 2.8 Clamping hub with axial slot without feather keyway
- 7.5 Half shell hub (DH) without feather keyway
- 7.8 Half shell hub (H) without feather keyway
- Type standard, AFN, BFN, CF, CFN, DKM, ZS-DKM, ZS-DKM-H and SP with hubs corresponding to the specifications above

ROTEX® DKM and ROTEX® ZS-DKM only with spacer made of steel or aluminium semi-finished products with a yield point of $R_{p0.2} \geq 250 \text{ N/mm}^2$.



Hubs, clamping hubs or similar types without feather keyways may be used in category 3 only and are marked with category 3 accordingly.

The hubs types 1.1 and 1.2 are not approved for potentially explosive atmospheres!

**10 Enclosure A**Advice and instructions regarding the use in  potentially explosive atmospheres**10.1 Intended use in  potentially explosive atmospheres**Conditions of operation in  potentially explosive atmospheres

ROTEX® couplings are suitable for the use according to EU directive 2014/34/EU.

1. Industry (with the exception of mining)

- Equipment group II of category 2 and 3 (*coupling is not approved/not suitable for equipment group 1*)
- Substance group G (*gases, fogs, vapours*), zone 1 and 2 (*coupling is not approved/not suitable for zone 0*)
- Substance group D (*dusts*), zone 21 and 22 (*coupling is not approved/not suitable for zone 20*)
- Explosion group IIC (*gases, fogs, vapours*) (*explosion group IIA and IIB are included in IIC*) and explosion group IIIC (*dusts*) (*explosion group IIIA and IIIB are included in IIIC*)

Temperature class:

Temperature class	PUR / T-PUR®	
	Ambient or operating temperature T _a ¹⁾	Max. surface temperature ²⁾
T4	-30 °C to +90 °C	+110 °C
T5	-30 °C to +75 °C	+95 °C
T6	-30 °C to +60 °C	+80 °C

Explanation:

The maximum surface temperatures each result from the maximum permissible ambient or operating temperature T_a plus the maximum temperature increase ΔT of 20 K to be considered. For the temperature class a safety margin subject to standard of 5 K is added.

- 1) The ambient or operating temperature T_a is limited to +90 °C due to the permissible permanent operating temperature of the elastomers used.
- 2) The maximum surface temperature of +110 °C applies for the use in locations which are potentially subject to dust explosion.

In potentially explosive atmospheres

- the ignition temperature of dusts generated must at least be 1.5 times the surface temperature to be considered
- the glow temperature must at least be the surface temperature to be considered plus a safety distance of 75 K.
- the gases and vapours generated must amount to the temperature class specified.

2. Mining

Equipment group I of category M2 (*coupling is not approved/not suitable for equipment group M1*).
Permissible ambient temperature -30 °C to +90 °C.



10 Enclosure A

Advice and instructions regarding the use in  potentially explosive atmospheres10.2 Inspection intervals for couplings in  potentially explosive atmospheres

Equipment category	Inspection intervals
3G 3D	For couplings operated in zone 2 or zone 22 the inspection and maintenance intervals of the usual operating/assembly instructions for standard operation apply. During the standard operation which has to be taken as a basis of the ignition risk analysis the couplings are free from any ignition source. For gases, vapours and dusts generated the permissible glow and ignition temperatures specified in chapter 10.1 have to be considered and observed.
M2 2G 2D No gases and vapours of explosion group IIC	An inspection of the torsional backlash and a visual inspection of the flexible spider/DZ elements must be performed after 3,000 operating hours for the first time, at the latest after 6 months after start-up of the coupling. If you note insignificant or no wear on the spider/DZ elements upon this initial inspection, further inspections can each be performed after 6,000 operating hours or at the latest after 18 months, provided that the operating parameters remain the same. If you note significant wear during the initial inspection so that it would be recommendable to replace the spider/DZ elements, find out the cause according to the table „Breakdowns“, if possible. The maintenance intervals must be adjusted to the modified operating parameters without fail.
M2 2G 2D Gases and vapours of explosion group IIC	An inspection of the torsional backlash and a visual inspection of the flexible spider/DZ elements must be performed after 2,000 operating hours for the first time, at the latest after 3 months after start-up of the coupling. If you note insignificant or no wear on the spider/DZ elements upon this initial inspection, further inspections can each be performed after 4,000 operating hours or at the latest after 12 months, provided that the operating parameters remain the same. If you note significant wear during the initial inspection so that it would be recommendable to replace the spider/DZ elements, find out the cause according to the table „Breakdowns“, if possible. The maintenance intervals must be adjusted to the modified operating parameters without fail.



Hubs, clamping hubs or similar types without feather keyways may be used in category 3 only and are marked with category 3 accordingly.



10 Enclosure A

Advice and instructions regarding the use in  potentially explosive atmospheres

10.2 Inspection intervals for couplings in  potentially explosive atmospheres

ROTEX® coupling

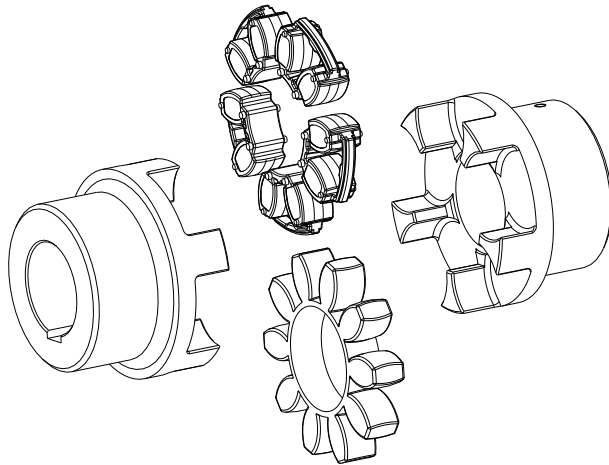

Illustration 16: ROTEX® coupling

Illustration 17.1:
ROTEX® DZ
elements

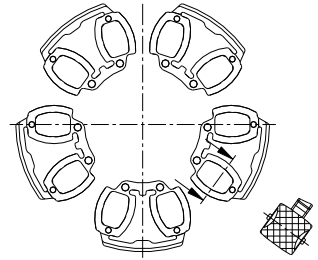
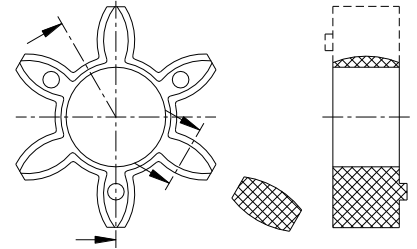

Illustration 17.2:
ROTEX® spider



Here the backlash between the cams of the coupling and the flexible spider/DZ element must be inspected by means of a feeler gauge.
When reaching the wear limit **maximum wear**, the spider/DZ element must be replaced immediately, irrespective of the inspection intervals.

Please observe protection note ISO 16016.	Drawn:	2019-07-02 Pz/Wb	Replacing:	KTR-N dated 2017-09-06
	Verified:	2019-07-23 Pz	Replaced by:	



10 Enclosure A

Advice and instructions regarding the use in  potentially explosive atmospheres

10.3 Standard values of wear

In case of backlash > X mm, the flexible spider/DZ elements must be replaced.

The general condition of the coupling can both be monitored at standstill and during operation. If the coupling is tested during operation, the operator must ensure an appropriate and proven test procedure (e. g. stroboscopic lamp, high-speed camera, etc.) which is definitely comparable to testing at standstill. Should any distinctive features arise, testing must be performed with the machine at standstill.

Reaching the limits for replacing depends on the operating conditions and the existing operating parameters.



In order to ensure a long service life of the coupling and avoid risks with the use in potentially explosive atmospheres, the shaft ends must be accurately aligned. Please absolutely observe the displacement figures indicated (see table 11 to 13). If the figures are exceeded, the coupling will be damaged.

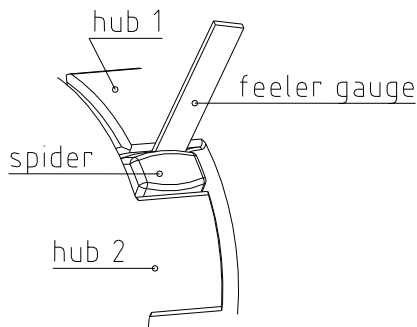

Illustration 18: Inspection of the limit of wear

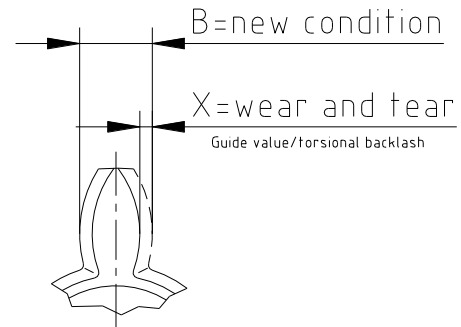

Illustration 19: Wear of spider

Table 14:

Size	Limits of wear (friction)		Size	Limits of wear (friction)	
	$X_{max.}$ [mm]			$X_{max.}$ [mm]	
9	2		65	5	
14	2		75	6	
19	3		90	8	
24	3		100	9	
28	3		110	9	
38	3		125	10	
42	4		140	12	
48	4		160	14	
55	5		180	14	

10 Enclosure A

Advice and instructions regarding the use in  potentially explosive atmospheres

10.4 marking of coupling for potentially explosive atmospheres

The ATEX marking of the ROTEX® coupling is applied on the outer sheath or on the front side.
The flexible spider resp. DZ element is not marked.

For the complete marking refer to the operating/assembly instructions and/or the delivery note/package.

The following marking applies for the products:

- Hubs resp. spacer **without aluminium**

Category 2 (hubs resp. clamping hubs with feather keyway)

ROTEX®
<Year>

		I M2 Ex h I II 2G Ex h IIC T6 ... T4 II 2D Ex h IIIC T80 °C ... T110 °C -30 °C ≤ T _a ≤ +60 °C ... +90 °C	Mb Gb Db
---	---	--	----------------

KTR Systems GmbH, Carl-Zeiss-Straße 25, D-48432 Rheine

- Hubs resp. spacer **without aluminium**

Category 3 (hubs resp. clamping hubs without feather keyway)

ROTEX®
<Year>

		I M2 Ex h I II 3G Ex h IIC T6 ... T4 II 3D Ex h IIIC T80 °C ... T110 °C -30 °C ≤ T _a ≤ +60 °C ... +90 °C	Mb Gc Dc
---	---	--	----------------

KTR Systems GmbH, Carl-Zeiss-Straße 25, D-48432 Rheine

- Hubs resp. spacer **made of aluminium only**

Category 2 (hubs resp. clamping hubs with feather keyway)

ROTEX®
<Year>

		II 2G Ex h IIC T6 ... T4 II 2D Ex h IIIC T80 °C ... T110 °C -30 °C ≤ T _a ≤ +60 °C ... +90 °C	Gb Db
---	---	---	----------

KTR Systems GmbH, Carl-Zeiss-Straße 25, D-48432 Rheine

- Hubs resp. spacer **made of aluminium only**

Category 3 (hubs resp. clamping hubs without feather keyway)

ROTEX®
<Year>

		II 3G Ex h IIC T6 ... T4 II 3D Ex h IIIC T80 °C ... T110 °C -30 °C ≤ T _a ≤ +60 °C ... +90 °C	Gc Dc
---	---	---	----------

KTR Systems GmbH, Carl-Zeiss-Straße 25, D-48432 Rheine

Short marking:

(A short marking is only made if there is no other option for reason of space or functioning.)

ROTEX®
<Year>

		
---	---	---

10 Enclosure A

Advice and instructions regarding the use in  potentially explosive atmospheres



10.4 marking of coupling for potentially explosive atmospheres

Deviating marking applies until 31st October 2019:



Short marking:

  II 2GD c IIC T X/I M2 c X

Complete marking:
(valid for T-PUR® only)

  II 2G c IIC T6, T5, T4 resp. T3 -50 °C ≤ T_a ≤ +65 °C, +80 °C,
+115 °C resp. +120 °C
II 2D c T 140 °C/I M2 c -50 °C ≤ T_a ≤ +120 °C

Complete marking:
(valid for PUR only)



  II 2G c IIC T6, T5 resp. T4 -30 °C ≤ T_a ≤ +65 °C, +80 °C resp.
+90 °C
II 2D c T 110 °C/I M2 c -30 °C ≤ T_a ≤ +90 °C

Substance group - gases, fogs and vapours:

The marking with explosion group IIC includes explosion groups IIA and IIB.

Substance group - dusts:

The marking with explosion group IIC includes explosion groups IIIA and IIIB.

If the symbol  was punched in addition to marking , the coupling component was supplied by KTR as an unbored or pilot bored version (see chapter 4.2 of the present operating/assembly instructions).



10 Enclosure A

Advice and instructions regarding the use in  potentially explosive atmospheres

10.5 EU Certificate of conformity

EU Certificate of conformity

corresponding to EU directive 2014/34/EU dated 26 February 2014
and to the legal regulations

The manufacturer - KTR Systems GmbH, D-48432 Rheine - states that the

flexible ROTEX® couplings

in an explosion-proof design described in the present operating/assembly instructions are devices corresponding to article 2, 1. of directive 2014/34/EU and comply with the general safety and health requirements according to enclosure II of directive 2014/34/EU.

The coupling described in here complies with the specifications of the following standards/rules:

- DIN EN ISO 80079-36
- DIN EN ISO 80079-37
- DIN EN ISO 80079-38
- IEC/TS 60079-32-1

The ROTEX® is in accordance with the specifications of directive 2014/34/EU.

According to article 13 (1) b) ii) of directive 2014/34/EU the technical documentation is deposited with the notified body (type examination certificate IBExU13ATEXB016 X):

IBExU
 Institut für Sicherheitstechnik GmbH
 Identification number: 0637
 Fuchsmühlenweg 7
 09599 Freiberg

Rheine,
Place

2019-07-02
Date

i. V. 
 Reinhard Wibbeling
 Engineering/R&D

i. V. 
 Michael Brüning
 Product Manager

KNF worldwide

You can find our local KNF partners at: www.knf.com