

**OEM**

**N952KNDC-B**

**TRANSLATION OF ORIGINAL  
OPERATING AND INSTALLATION  
INSTRUCTION  
ENGLISH**

# DIAPHRAGM PUMP

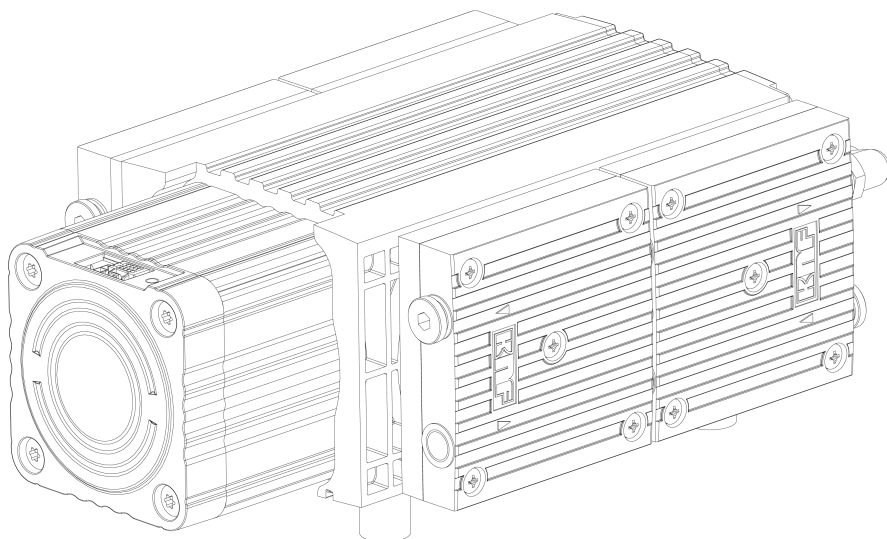

**Notice!**

Before operating the pump and accessories, read and observe the operating and installation instructions as well as the safety information!

## Table of contents

1	About this document .....	4
1.1	Using the operating and installation instructions.....	4
1.2	Exclusion of liability.....	4
1.3	Symbols and markings.....	5
2	Safety .....	7
2.1	Personnel and target group .....	7
2.2	Responsibility of the operator .....	8
2.3	Working in a safety conscious manner .....	8
2.4	Operating conditions .....	9
2.5	Media .....	9
2.6	Use.....	10
2.7	Directives and standards .....	11
2.8	Customer service and repair.....	12
2.9	Disposal .....	12
3	Technical data.....	13
3.1	Technical data.....	13
4	Product description .....	16
5	Transport.....	18
	General .....	18
6	Installation and connection.....	20
6.1	Installing the pump.....	20
6.2	Electrical connection .....	22
6.3	Pneumatic connection.....	27
7	Operation .....	29
7.1	General .....	29
7.2	Information on switching the pump on and off .....	32
7.3	Speed specification [.29 version] .....	33
7.4	Extended parameterization and functions of the pump [.29 version] .....	38
8	Servicing .....	41
8.1	Servicing schedule.....	41
8.2	Cleaning.....	42
8.3	Replacing the diaphragm and valve plates.....	43
9	Spare parts and accessories.....	52
9.1	Spare parts .....	52
9.2	Accessories.....	52

9.3 Motor accessories.....	53
10 Troubleshooting .....	54
11 Returns.....	58

# 1 About this document

## 1.1 Using the operating and installation instructions

The operating and installation instructions are part of the pump.

- In the event of uncertainties with regard to the content of the operating and installation instructions, please contact the manufacturer (contact data: see [www.knf.com](http://www.knf.com)). Please have the type and serial number of the pump ready.
- Read the operating and installation instructions before you commission the pump.
- Give the operating and installation instructions only completely and unchanged to the next owner.
- Keep the operating and installation instructions within reach at all times.

**Project pumps** For customer-specific project pumps (pump models that begin with "PJ" or "PM"), there may be deviations from these operating and installation instructions.

- For project pumps, also observe the agreed specifications.

**Optional contents** Project-specific options may be included in the operating and assembly instructions. These are marked with "Optional". It is also possible that project-specific deviations are not included in the operating and assembly instructions.

## 1.2 Exclusion of liability

The manufacturer assumes no liability for damages and malfunctions resulting from failure to observe the operating and installation instructions.

The manufacturer assumes no liability for damages and malfunctions resulting from changes or modifications to the device and improper handling.

The manufacturer assumes no liability for damages and malfunctions resulting from impermissible spare parts and accessories.

## 1.3 Symbols and markings

### Warning notice



A notice that warns you of danger is located here.

Possible consequences of a failure to observe the warning notice are specified here. The signal word, e.g., Warning, indicates the danger level.

→ Measures for avoiding the danger and its consequences are specified here.

### Danger levels

Signal word	Meaning	Consequences if not observed
DANGER	warns of immediate danger	Death or serious injury or serious damage will result.
WARNING	warns of possible danger	Death, serious injury or serious damage is possible.
CAUTION	warns of a possibly dangerous situation	Minor injury or damage is possible.
NOTICE	Warns of possible damage	Damage is possible.

Tab. 1: Danger levels







### Other notices and symbols

→ An activity to be carried out is specified here (a step).

1. The first step of an activity to be carried out is specified here.  
Other sequentially numbered steps follow.

**i** This symbol indicates important information.

**Explanation of pictograms**

Pictogram	Meaning
	General warning symbol
	Warning of hot surface
	Warning of electrical voltage
	Warning of poisonous substances
	Warning of hand injuries through crushing
	Observe the operating instructions
	General mandatory sign

*Tab.2: Explanation of pictograms*

## 2 Safety

**i** Observe the safety notices in Chapters 6 *Installation and connection* [▶ 20] and 7 *Operation* [▶ 29].

### 2.1 Personnel and target group

**Personnel** Make sure that only specially trained and instructed personnel work on the pumps. This applies, in particular, to mounting, connection and servicing work.

Make sure that the personnel have read and understood the operating instructions, particularly the chapter on safety.

**Target group**

Target group	Definition
User	Employee
Specialized personnel	Specialized personnel are personnel who - have relevant professional training in the field covered in the particular section of text; - have current knowledge of the field covered in the particular section of text.

Tab.3: Target group

**Who-does-what matrix**

Lifecycle phase	User	Specialized personnel
Transport		X
Mounting		X
Connection		X
Commissioning	X	X
Operation	X	X
Servicing		X
Troubleshooting		X
Disposal		X

Tab.4: Who-does-what matrix

## 2.2 Responsibility of the operator

The pumps are produced in accordance with the generally recognized rules of engineering, as well as the occupational health, safety and accident prevention regulations. Nevertheless, dangers can arise during their use that lead to injuries to the user or third parties or to damage to the pump or other property.

Only use the pumps in perfect technical condition, for their intended use, safely and with an awareness of the dangers and in observation of the operating and installation instructions.

The components that are to be connected to the pumps must be designed according to the pneumatic data of the pumps.

When connecting the pumps to the electrical power, observe the corresponding safety rules.

Make sure that no hazardous situation, physical harm or impairment of the pump can occur.

Operating parameters

Only operate and install the pump under the operating parameters and operating conditions described in Chapters 2.4 *Operating conditions* [▶ 9] and 3 *Technical data* [▶ 13].

## 2.3 Working in a safety conscious manner

Observe the regulations on accident prevention and safety during all work on the pumps and during operation.

Avoid contact with the pump heads and housing parts because the pump heats up during operation.

When working on the pump, make sure that the pump is disconnected from mains and without power.

When connecting the pump to the electrical mains, observe the corresponding safety rules.

Ensure that no hazards arise from gas flowing when gas connections are open, from the effects of noise or from hot, corrosive, dangerous and environmentally hazardous gases.

Make sure that an EMC-compliant installation of the pump is ensured at all times to prevent the occurrence of dangerous situations.



## 2.4 Operating conditions

Only use the pump in perfect technical condition, for its intended purpose, safely and with an awareness of the dangers and in observation of the operating instructions.

Only install and operate the pumps in accordance with the operating parameters and conditions described in Chapter 3 *Technical data* [▶ 13].

Only pumps that are fully assembled and in the condition as delivered may be operated.

Make sure that the installation location is dry and that the pump is protected from rain, splash water, gushing water, dripping water and other contamination.

Check the tightness of the connections between the pipes of the application and the pump (or the connection of the pump) at regular intervals. Leaky connections carry the risk of releasing dangerous gases and vapors from the pump system.

## 2.5 Media

**Requirements of pumped media** Before transferring a medium, check whether the medium can be transferred without risk in the specific application.

Take note of any change in the state of matter (condensation, crystallization).

Before using a medium, check the compatibility of the media-contacting components (see 3 *Technical data* [▶ 13]) with the medium.

Risk of dangerous gas mixtures during pump operation if diaphragm breaks: Depending on the medium being transferred, breakage of the diaphragm can result in a dangerous mixture if the medium mixes with the air in the compressor housing or the surroundings.

Only transfer gases that remain stable under the pressures and temperatures that arise in the pump.

**Handling of hazardous media** Upon breakage of the diaphragm and/or leaks, the transferred medium mixes with the air in the surroundings and/or in the pump housing.

Make sure that a dangerous situation cannot arise as a result.

When pumping hazardous media, observe the safety regulations for the handling of said media.

- Handling of combustible media
- Note that the pump is not designed to be explosion-proof.
- Make certain that the temperature of the medium is always sufficiently below the ignition temperature of the medium so as to prevent ignition or explosion. This also applies for abnormal operating situations.
- Note that the temperature of the medium increases when the pump compresses the medium.
- Therefore, make certain that the temperature of the medium also remains sufficiently below the ignition temperature of the medium even when it is compressed to the maximum permissible operating pressure of the pump. The maximum permissible operating pressure of the pump is stated in Chapter 3 *Technical data* [▶ 13].
- Make certain that the permissible ambient temperature (see 3 *Technical data* [▶ 13]) is not exceeded.
- Where applicable, also take into account external energy sources (such as radiated heat sources) that could additionally heat the medium.
- In case of doubt, contact KNF Customer Service.

## 2.6 Use

### 2.6.1 Proper use

The pumps are intended exclusively for transferring gases and vapors.

The pumps are intended exclusively for operation in indoor areas and in non-explosive atmospheres.

### 2.6.2 Foreseeable misuse

The pumps must not be operated in explosive atmospheres.

The pumps are not suitable for transferring the following:

- Dusts
- Liquids
- Aerosols
- Biological and microbiological substances

- Fuels
- Explosives and flammable materials
- Fibers
- Oxidizing agents
- Foodstuffs.

As standard, the pumps must not be used for simultaneous generation of a vacuum and positive pressure.

This function can be made possible on a project basis following consultation with KNF Customer Service.

Do not apply positive pressure to the inlet of the pump.

This function can be made possible on a project basis following consultation with KNF Customer Service.

## 2.7 Directives and standards

EU/EC  
Directives

### **Installation declaration – for partly completed machinery**

With respect to the Machinery Directive 2006/42/EC, the pumps are partly completed machinery and are, therefore, to be regarded as not ready for use. Partly completed machinery may not be commissioned until it has been determined that the machine into which the partly completed machinery is to be installed complies with the provisions of the Machinery Directive 2006/42/EC. The following fundamental requirements of Annex I of Directive 2006/42/EC (general principles) are applied and observed:

- General principles no. 1
- No. 1.1.2. / 1.1.3. / 1.3.1. / 1.3.3. / 1.3.4. / 1.4.1. / 1.5.8. / 1.5.9. / 1.7.4. / 1.7.4.1. / 1.7.4.3.

Standards

The following standards apply:

- EN IEC 61000-6-2
- EN IEC 61000-6-3
- EN IEC 63000

The protective goals of the following directive(s) are achieved:

- Directive 2011/65/EU on the restriction of the use of certain hazardous substances in electrical and electronic equipment (Annex II changed by delegated Directive (EU) 2015/863 of the Commission)

## 2.8 Customer service and repair

Customer service and repairs The pump is maintenance-free. However, KNF recommends periodic inspection of the pump for obvious changes in noise or vibration.

Only have repairs to the pumps performed by qualified KNF personnel.

Housings with electrically live components may only be opened by specialist personnel.

Use only genuine spare parts from KNF when performing servicing work.

## 2.9 Disposal

Environmental protection Store the pump and all accessories in accordance with the environmental provisions. Observe national and international regulations. This applies in particular to parts that are contaminated with toxic substances.

If you no longer need your packaging materials (e.g. for return shipment or other transport of the device), dispose of them in an environmentally friendly manner.

Old devices must not be disposed of with household waste. Proper disposal and recycling helps to protect natural resources and the environment. The end user is responsible for disposing of old devices according to national and international regulations. Alternatively, KNF products (old devices) may also be returned to KNF for a fee (see chapter 11 *Returns* [p. 58]).

## 3 Technical data

### 3.1 Technical data

#### Pump materials

Assembly	Material
Pump head	PPS
Diaphragm	EPDM
Valve plate	FPM
O-ring	FPM
Pneumatic connection -Male connection -Hose -O-ring	Nickel-plated brass PFAN FPM

Tab.5:

#### Pneumatic parameters

Parameter	Value
Max. permissible operating pressure [bar rel]	0,1
Ultimate vacuum [mbar abs.]	≤ 1.5
Flow rate at atm. pressure [l/min]*	36

Tab.6: \*Liters in the standard state (based on ISO 8778 and ISO 21360-1/2) (1013 mbar)

**Electrical performance**

Parameter	Value
Motor type	Brushless DC motor
Voltage [V]	24
Max. permissible supply voltage fluctuations	± 10%
Power P <sub>1</sub> [W]	100
Max. rated current draw [A]	4,2
Motor protection class (DIN EN 60529 / IEC 60529)	IP20
Overvoltage category	I

Tab.7: Electrical performance

**Other motor values**

Designation	Value
Minimum signal voltage	-0.3 V
Maximum signal voltage	5.2 V
Maximum output current per signal	5 mA
Input impedance	5 kΩ
High logic level	2.9...5 V
Low logic level	0...0.4 V
Max. cable length	≤ 3m

Tab.8: Maximum electrical values

**Pneumatic connections**

Pneumatic connections	Value
Inlet	Thread size G1/8*
Outlet	Thread size G1/8*

Tab.9: \*Acc. to ISO 228

**Other parameters**

<b>Parameter</b>	<b>Value</b>
Permissible ambient temperature [°C]	+ 5 to + 40
Permissible media temperature [°C]	+ 5 to + 40
Operating temperature of drive controller (this can be read out via UART)	0...90°C (depending on the boundary conditions, the limit temperature can be parameterized to 100°C)
Relative air humidity	80% for temperatures to 31 °C, decreasing linearly to 50% at 40 °C (non-condensing).
Maximum installation altitude [m above sea level]	2000
Dimensions	See Fig. 3, Chapter 6.1 <i>Installing the pump</i> [▶ 20]
Degree of contamination	2

Tab. 10:

**Weight**

<b>Parameter</b>	<b>Value</b>
Weight [kg]	4,8

## 4 Product description

### Design

- 1 Outlet
- 2 Motor
- 3 Inlet

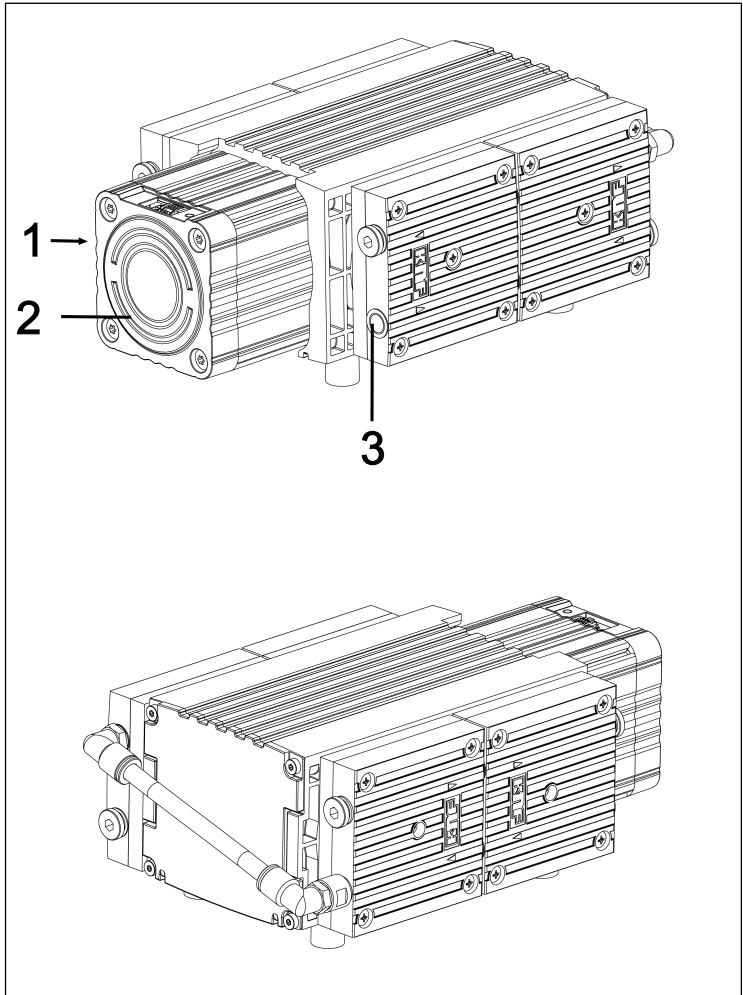
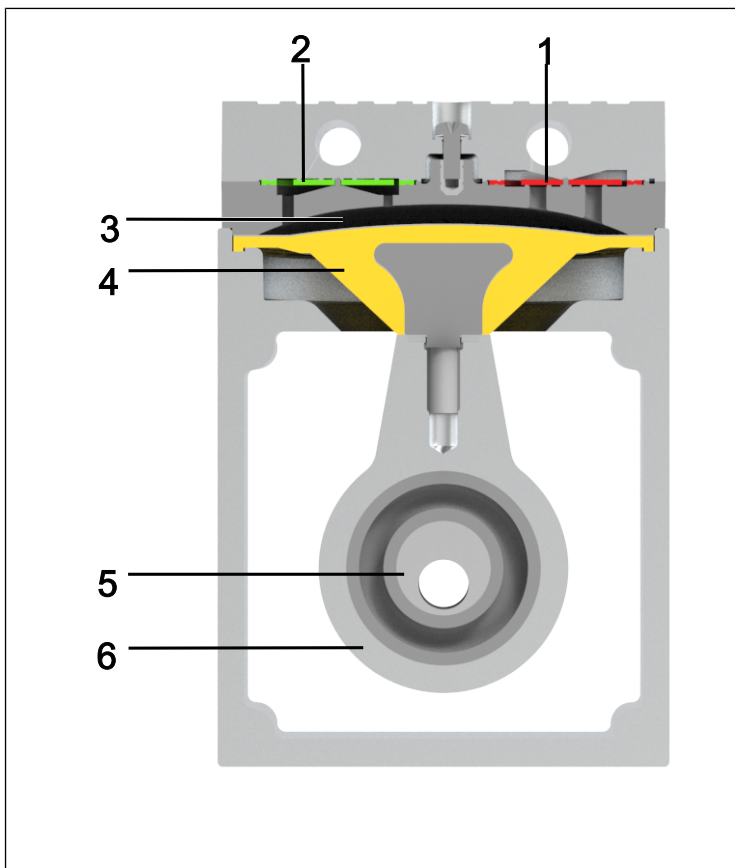

Fig. 1: Diaphragm pump N952KNDC-B



### Function of a diaphragm pump

- 1 Outlet valve
- 2 Inlet valve
- 3 Transfer chamber
- 4 Diaphragm
- 5 Eccentric
- 6 Connecting rod



*Fig.2: Function of a diaphragm pump*

Diaphragm pumps transfer, compress (depending on the version) and evacuate gases and vapors.

The elastic diaphragm (4) is moved up and down by the eccentric (5) and the connecting rod (6). In the downwards stroke, it aspirates the gas to be transferred via the inlet valve (2). In the upwards stroke, the diaphragm presses the medium out of the pump head via the outlet valve (1). The transfer chamber (3) is separated from the pump drive by the diaphragm.

## 5 Transport

### General

---



#### CAUTION

Personal injury and/or property damage due to incorrect or improper transport of the pump

In the event of incorrect or improper transport, the pump can fall down, be damaged or injure persons.

- Use suitable auxiliary means if necessary (carrying strap, lifting gear, etc.).
  - Where appropriate, wear suitable personal protective equipment (e.g., safety shoes, safety gloves).
- 



#### CAUTION

Risk of injury from sharp edges on the packaging

There is a risk of injury from cutting on the sharp edges when grabbing corners or when opening the packaging.

- Where appropriate, wear suitable personal protective equipment (e.g., safety shoes, safety gloves).
-



Personal injury and/or property damage due to incorrect or improper transport of the pump

If the pump is raised and/or carried on the connection during transport, leaks and/or damages to the pump may result.

→ Do not carry the pump on the pneumatic connection.

- Transport the pump in the original packaging to the installation location.
- Keep the original packaging of the pump (e.g. for later storage).
- Inspect the pump for transport damage after receiving it.
- Document any transport damage that has occurred.
- Remove any transport safeguards on the pump prior to commissioning.

### Parameter

Parameter	Value
Storage temperature [°C]	+ 5 to + 40
Transport temperature [°C]	- 10 to + 60
Permissible humidity (non-condensing) [%]	30 to 85

Tab. 11: Transport parameters and storage parameters



Prior to commissioning, make sure that the pump has reached the ambient temperature (3 *Technical data* [▶ 13]).

## 6 Installation and connection

Only install the pumps in accordance with the operating parameters and conditions described in Chapter 3 *Technical data* [▶ 13].

- Observe the safety instructions (see Chapter 2 *Safety* [▶ 7]).



**DANGER**

Risk of dangerous gas mixtures during pump operation

Depending on the medium being transferred, breakage of the media-contacting components can result in a dangerous mixture if the medium mixes with the air in the compressor housing or the surroundings.

- Before using a medium, check the compatibility of the media-contacting components (see 3 *Technical data* [▶ 13]) with the medium.

---

### 6.1 Installing the pump

- Store the pump at the installation site to allow it to adapt to the ambient temperature before installation (condensation must not be allowed to form).

Mounting dimensions

- For mounting dimensions, see the following illustrations:

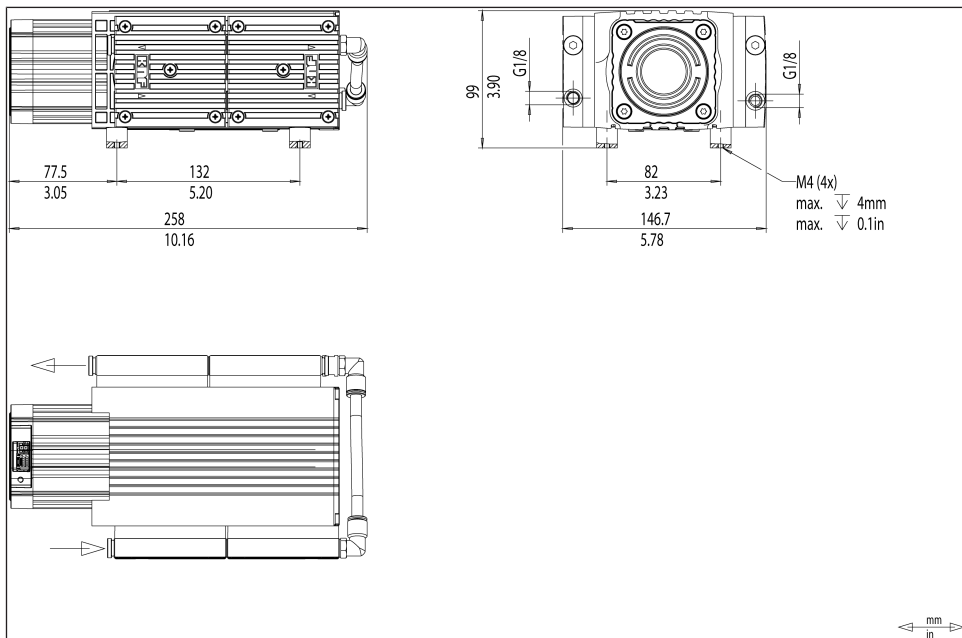

Fig. 3: Mounting dimensions N952KNDC-B

Cooling air supply



**WARNING**

Danger of burning on hot surfaces

Hot surfaces could occur if the pump overheats.

→ When installing the pump, make sure that sufficient cooling air in-feed and discharge is ensured.

Proximity to hot pump parts

→ During installation, make sure that no combustible or thermally deformable objects are positioned in proximity to hot pump parts (head, motor).

Installation location

→ Make sure that the installation location is dry and that the pump is protected from rain, spray water, splash water, dripping water and other contaminants.

→ Make sure the installation location allows access for servicing.

Installation position

- i** The IP protection class of the pump motor is specified on the type plate.
- Install the pump at the highest point in the system to prevent condensate from collecting in the pump head.
- Protect the pump from dust.
- Protect the pump from vibration and impact.
- The pump can be operated in any installation position. Use metal screws to fasten the pump at the indicated attachment points. Observe the specifications of the selected fasteners.

## 6.2 Electrical connection

---

**DANGER**

Danger to life from electric shock

- Only have the pump connected by an authorized specialist.
- Only have the pump connected if the power supply is disconnected.

- 
- When connecting to a power source, observe the applicable standards, regulations, directives, and technical standards.

**WARNING**

Risk of injury due to electrical shocks

- Fuse the power source with 10 A on the secondary side.
  - Fuses must be designed by qualified electricians.
-



Risk of injury due to electrical shocks

If the drives are not operated in a SELV circuit, this may result in injuries due to electrical shocks.

→ The drives may only be operated in an SELV circuit.

**i** Refer to the type plate for the maximum current consumption of the pump.

→ Install an Emergency Off device such that it is not possible for there to be an automatic restart or for hazardous situations to persons and property to occur.

→ Install the pumps in such a way that it is not possible to touch electrically live parts (electrical connection).

Fastening the  
connection ca-  
bles

→ Fasten the connection cables so that

→ the cables do not come into contact with movable or hot parts.

→ the cables cannot be worn or damaged on sharp corners or edges

→ no tensile and pressure forces are exerted on the connection point of the cables (strain relief)

### Connecting the pump

1. Confirm that the power supply meets the parameters listed on the pump type plate. Refer to the pump type plate for the rated current draw.
2. Connect the positive and negative terminals.
3. Connect the signal connector according to 6.2.2 *Signal connector* [► 25].

**i** Ensure the correct polarity:

Red connection cable: +

Black connection cable: -

## 6.2.1 Supply connector

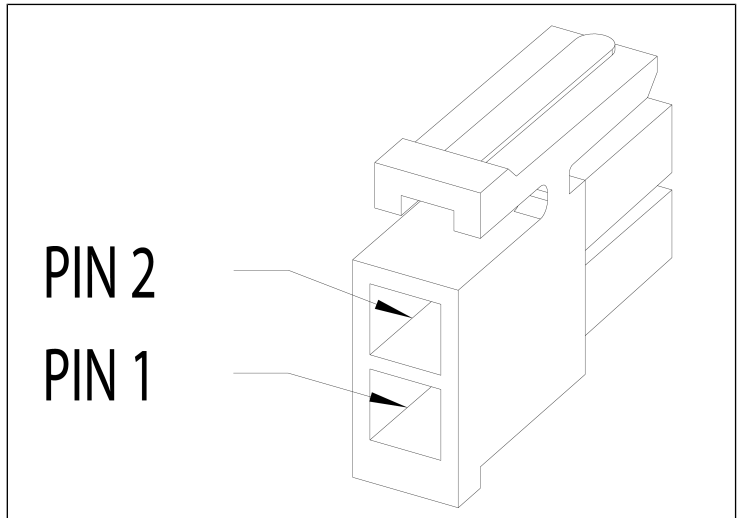

Fig. 4: Supply connector

Designation	Manufacturer	Type (manufacturer)
Connector housing	Amphenol	10132445-02LF
Crimp contact	Amphenol	10132447-111PLF
Cable	-	AWG 18, $\geq 105^{\circ}\text{C}$ Cable length $\leq 3\text{m}$

Tab. 12: Supply connectors

Pin number	Color	Description
1	Black	Voltage supply GND
2	Red	Voltage supply 24 V

Tab. 13: Pin assignment for supply connector



### 6.2.2 Signal connector

Designation	Manufacturer	Type (manufacturer)
Connector housing	Amphenol	5031491000
Crimp contact	Amphenol	5025790000
Cable	-	AWG 24, $\geq 105^{\circ}\text{C}$ Cable length $\leq 3\text{m}$

Tab. 14: Signal connector

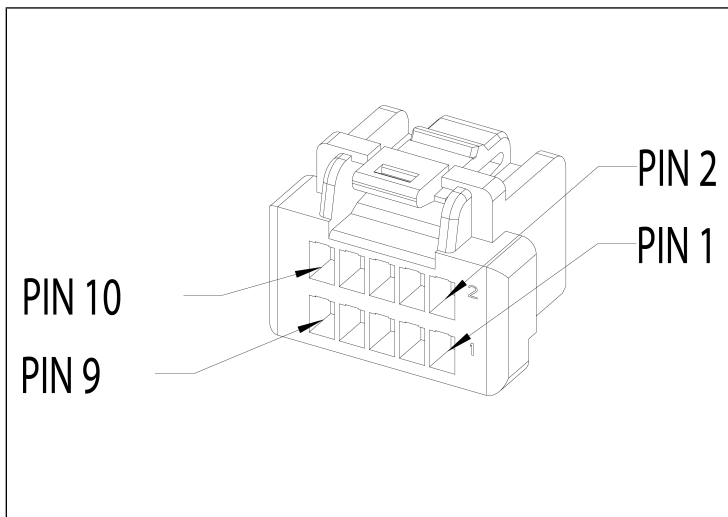

Fig. 5: Signal connector

Pi n no.	Color <sup>1</sup>	Description	Level / state	
1	White	<u>Input</u> Analog speed set- point setting	0...5V (see 7.3.1 <i>Analog control voltage</i> [▶ 33])	
2	Or- ange	<u>Input</u> UART	Tx <sup>3</sup> (see <i>Tab. 16</i> [▶ 34])	
3	Black	GND <sup>2</sup>	0V	
4	Yellow	<u>Output</u> UART	Rx <sup>3</sup> (see <i>Tab. 16</i> [▶ 34])	
5		NC	Not connected	
6	Blue	<u>Input</u> PWM speed set- point setting	LVTTTL <sup>3</sup> 1...99% (100 Hz-5 kHz)	
7	Green	<u>Input</u> Remote ON/OFF	Off <sup>3</sup> = Logical 1 On = Logical 0	
8	Brown	GND <sup>2</sup>		
9	Red	<u>Output</u> Speed feedback	PWM LVTTTL <sup>3</sup> 1...99% 1kHz	Upon customer re- quest, parameteriz- able as speedo out- put: 6 or 60 pulses per revolution
10	Violet	<u>Output</u> Error signal	Error = Logical 1 No error = Logical 0	
If no supply voltage is present, the inputs must be potential-free!				

*Tab. 15: Assignment of control cable connection*

<sup>1</sup> Color assignment - KNF standard control cable ID: 322551

<sup>2</sup> GND potential internally connected

<sup>3</sup> All digital signals are LVTTTL (3.3 V);

*The signal direction is defined from the application to the pump.*

*The Rx and Tx designations are a matter of definition, depending on how the motor is defined as a device (as DTE or DCE); see TIA/EIA-232-F conformance). Furthermore, the device which the motor communicates with (from the customer's point of view) is also a matter of definition.*

## 6.3 Pneumatic connection



Personal injury or property damage through ejected plugs

If not removed, the plugs on the outlet of the pump can be ejected during operation by the resulting overpressure.

- Remove the plugs during installation.
- Wear appropriate personal protective equipment.

- |                      |  |
|----------------------|--|
| Connected components | → Only connect components to the pump that are designed for the pneumatic data and thermal requirements of the pump. (see Chapter 3 <i>Technical data</i> [▶ 13]).   |
| Pump discharge       | → Discharge the possibly hot pump discharge at the pneumatic outlet of the pump safely (with regard to medium and noise).  |
| Decoupling           | → KNF recommends mechanically decoupling the pump from the pipe system, e.g., through the use of flexible hoses or pipes. In this way it is possible to prevent the transfer of possible pump vibrations and noises to the system. |

### Connecting the pump

- i** A marking on the pump head indicates the flow direction.



Risk of injury due to mixing up inlet and outlet

Mixing up the inlet and outlet may cause breakage of components connected at the inlet and outlet.

- Observe the marking of inlet and outlet on the pump head.

1. Remove the protective plugs from the hose connection threads.
2. Connect the suction line and the pressure line (for mounting dimensions, see Chapter 3 *Technical data* [p. 13]).
3. Lay the suction line and pressure line with a descent so that no condensate can run into the pump.

## 7 Operation

### 7.1 General

---



#### WARNING

Risk of burns from hot pump parts and/or hot medium

Some pump parts may be hot during or after operation of the pump.

- Allow the pump to cool after operation.
  - Take protective measures to protect against touching hot parts.
- 



#### WARNING

Injury to eyes

Coming too close to the inlet/outlet of the pump may result in injury to the eyes due to the present vacuum/operating pressure.

- Do not look into the pump inlet/outlet during operation.
- 

- Only operate the pumps under the operating parameters and operating conditions as described in Chapter 3 *Technical data* [▶ 13].
- Ensure the proper use of the pumps (See Chapter 2.6.1 *Proper use* [▶ 10]).
- Rule out the possibility of foreseeable misuse of the pumps (see chapter 2.6.2 *Foreseeable misuse* [▶ 10]).
- Observe the safety instructions (Chapter 2 *Safety* [▶ 7]).



Risk of bursting of pump head due to excessive pressure increase

- Do not exceed the maximum permissible operating pressure (see 3 *Technical data* [p. 13]).
- Monitor the pressure during operation.
- If the pressure exceeds the maximum permissible operating pressure of the pump: Switch the pump off immediately and remedy the malfunction (see Chapter 10 *Störung beheben* [p. 54]).
- Only throttle or regulate the air or gas quantity on the inlet line to prevent the maximum permissible operating pressure from being exceeded.
- If the air quantity or gas quantity on the outlet line is throttled or regulated, make sure that the maximum permissible operating pressure at the pump is not exceeded.
- Ensure that the pump outlet is not closed or restricted.



Excessive pressure, with all of the associated hazards, can be prevented by means of a bypass line with a pressure relief valve between the outlet and inlet of the pump. Further information is available from KNF Customer Service (contact data: see [www.knf.com](http://www.knf.com)).



Risk of dangerous gas mixtures during pump operation if diaphragm breaks

If the diaphragm should break, the medium will mix with the air in the compressor housing or in the surroundings.

- Stop pump immediately.
- Replace the diaphragm prior to further operation (see Chapter 8 *Servicing* [▶ 41]).



Operation with open gas connection at the inlet can result in contaminants and objects being drawn in.

- Pump standstill → When the pump is at a standstill, establish normal atmospheric pressure in the lines.
- Vapors as medium    The service life of the diaphragm can be extended, if no condensate forms in the pump. Therefore:
- Perform any work with saturated or near-saturated vapors only with a warm pump.
  - KNF recommends: When pumping corrosive media, flush the pump before switching off (see Chapter 8.2.1 *Flushing the pump* [▶ 42]) to extend the service life of the diaphragm.

## 7.2 Information on switching the pump on and off

### Switching on the pump



#### NOTICE

The pump must not start up against pressure during switch-on. This also applies after a brief power interruption during operation. If a pump starts up against pressure, pump may go into a stall condition.

- Install an overload protector (see Chapter 6.2 *Electrical connection* [▶ 22]).

- 
- Ensure that normal atmospheric pressure is present in the lines when switching on.
  - Switch the pump on with the power switch (see Product description N952KNE-W).
  - i** Initialization of the electronics can take as long as a second before the pump starts up, depending on the level of the applied electrical voltage.

### Switching off/decommissioning the pump

- Switch the pump off with the power switch (see Product description N952KNE-W).
  - Establish normal atmospheric pressure in the lines (relieve pump pneumatically).
  - Pull out power plug of the pump.
- Recommissioning
- Before recommissioning, observe the applicable standards, guidelines, regulations and technical standards at the electrical connection.
- Inspecting the pump
- Inspect the pump periodically for external damage or leakage.



## 7.3 Speed specification [.29 version]

The pump can be actuated by analog or digital means. The speed setpoint of the pump can be carried out by one of three options:

- Analog control voltage,
- PWM setpoint setting,
- Digital setpoint setting.
- As an option, it is possible to have the speed set to a fixed value by the manufacturer. In this case, the pump does not need any speed setting signals.

A standard-analog configured pump can be switched to digital mode at any time with the start command "dU" via the UART interface. The pump then remains in this mode until it is actively disconnected from the supply voltage.

Functional status parameters can be read out via the UART interface at any time, even if the setpoint is set using analog voltage.

### 7.3.1 Analog control voltage

The speed of the pump is scaled directly proportionally to the control voltage as follows:

- minimum speed = minimum control voltage of 0.1 V,
- maximum speed = maximum control voltage of 5.0 V.

If the control voltage is below 0.1 V, by default the pump remains OFF.

The speed is set via the analog voltage at pin 1 of the 10-pin signal connector (see *Tab. 15* [▶ 26]).

### Optional settings

Upon request, the following settings can be altered by the manufacturer:

- Changing the minimum and maximum values for control voltage in the range from 0...5 V,
- Behavior of the pump when control voltage falls below the minimum value:
  - Pump stops **or**

- Pump continues working at minimum speed. In this case, the pump can only be switched off via REMOTE ON/OFF ( *Tab. 15 [▶ 26]/Pin 7*).
- The lower and upper speed limits can be parameterized within the permissible range according to the customer's requirements.

### 7.3.2 PWM setpoint setting

The PWM signal can be set according to the values from *Tab. 15 [▶ 26]*. The signal is directly proportional to the speed: 1% PWM means minimum speed of the pump and 99% of the maximum speed.

If two signals for the speed setting are present at the same time: at pin 6 as PWM signal and at pin 1 as analog signal, the PWM signal is taken as the setpoint and the analog signal is ignored.

### 7.3.3 Digital setpoint setting

#### Interface configuration

Designation	Value
Baud rate	57600 bits/s
Data bits	8
Parity	none
Stop bits	1
Flow control	none

*Tab. 16: Settings of the UART interface*

#### Interface protocol

Tables *Tab. 17 [▶ 35]* to *Tab. 19 [▶ 37]* contain the command sets necessary for the interface protocol, expressed as ASCII characters. Each of the commands is to be terminated with <CR> (carriage return, decimal value 013). The answers from *Tab. 17 [▶ 35]* are symbols. The symbols are explained in *Tab. 19 [▶ 37]*.

There must be a pause of 25 ms between each UART command and the next command.

Input values are only processed by the controller as whole numbers (integers).

Parameter	Command	Function	Answer
Start	dU	Pump start	S ; E
Stop	dE	Pump stop	S ; E
Set speed setpoint	dSnnn n	Specify speed setpoint (nnnn = target speed in rpm in the range of nl and nh)	ns ; E
Status	pP	Readout of status values	ni ; ii ; ti ; ei (see 7 <i>Operation</i> [▶ 29]) ; E Actual speed; Current draw; Motor temperature; Status;
Status optional	gP	Status values (single value)	ei ; E
Read speed setpoint	gS	Readout of current speed setpoint	ns ; E
Minimum speed setpoint	gSl	Readout of the parameters for minimum speed	nl ; E
Maximum speed setpoint	gSh	Readout of the parameters for maximum speed	nh ; E
Firmware version number	iV	Readout of firmware version	V ; E

Tab.17: UART protocol



### Motor error management

- Default setting An error can only be acknowledged by switching off the supply voltage and switching it back on.
- Optional setting If the pump receives its speed setpoint setting via the analog input, errors that occur can be acknowledged via the "Remote ON/OFF" digital input. For this, the "Remote ON/OFF" digital input must be on "logical 1" for at least 250 ms. All errors are acknowledged as soon as "Remote ON/OFF" is switched to "logical 0" again.

If the setpoint is set digitally via UART, errors can be acknowledged directly with the command on the interface. For this, the command "dB" must be sent. Then, all errors that occurred are acknowledged.

For further information, please contact KNF Customer Service ([www.knf.com](http://www.knf.com)).

Symbol	Description
E	Success report: 0 Command cannot be executed 1 Command executed ? Command not clear
S	Status message (Pump receives start command: S=1; Pump receives stop command: S=0) (For Service only)
V	Firmware version (example: 01.005;1)
ni	Actual speed in rpm
ns	Setpoint speed in rpm
nl	Parameters for minimum speed in rpm
nh	Parameters for maximum speed in rpm
ii	Current draw in mA
ti	Motor temperature in °C
ei	Status register (see <i>Troubleshooting</i> [▶ 57])

Tab. 19: Symbols

### Pump START

To start the pump, see chapter *Start parameters of the pump* [▶ 39].

The factory setting for the pump when the operating voltage is supplied is OFF.

Optionally, the pump can be parameterized such that when the operating voltage is supplied the pump starts immediately at a defined starting speed. This speed must be agreed with KNF in advance and must lie within the minimum and maximum speed range specific to the product.

### Setpoint speed

Setting of the pump speed within the maximum and minimum speed limits.

The following process parameters can be read out with the pump in both digital and analog modes:

- Actual and setpoint speeds
- Minimum and maximum speed limits
- Motor current
- Temperature of the motor
- Status values
- Firmware version number

## 7.4 Extended parameterization and functions of the pump [.29 version]

### Speed output

Information about the current speed of the pump is present in the form of a digital signal at pin 9 of the 10-pin signal connector of the motor (see *Tab. 15* [▶ 26]).

The speed signal is a digital, pulse-width modulated (PWM) signal which is proportional to the speed of the pump. The frequency of the signal is constant, the high pulse time varies between 1 and 99% of the period time.

The values correspond as follows:

1%	=	0 rpm
99%	=	4900 rpm*
PWM in % = 1+(0.02*rpm)		

*Tab.20: \*The maximum speed of the pump is defined by the respective parameterization.*

### Optional settings for the speed output

At the customer's request, the output signal for the speed may be output as a frequency (Tach signal). In this case, 6 or 60 pulses per revolution may be selected. The frequency that is output is directly proportional to the speed of the pump.

### Remote ON/OFF

Remote ON/OFF is enabled via the 10-pin connector on the motor (Pin 7, see *Tab. 15 [▶ 26]*).

To start the pump, pin 7 must be set to logical 0 according to *Tab. 15 [▶ 26]*.

Further functional applications of "Remote ON/OFF" can be found in Chapter *Start parameters of the pump [▶ 39]*.

### Start parameters of the pump

Remote ON/OFF In order to control the ON and OFF behavior of the pump, the signal from the "Remote ON/OFF" pin (*Tab. 15 [▶ 26]*/**Pin 7**) can be parameterized. In this case, various signal states can be used to start and stop the pump. This parameter is set in different ways depending on how the pump receives its speed setpoint setting (analog inputs or via UART).

### With analog speed setpoint

Starting behavior of pump (standard) The pump responds in direct inverse proportion to the state of the "Remote ON/OFF" input. That is to say, when a "logical 1" is at the input, the pump is OFF, and when a "logical 0" is at the "Remote ON/OFF" input, the pump is ON.

Starting behavior of pump (optional) **i** All pump starting behaviors marked "Optional" must be parameterized by KNF.

After the supply voltage is switched on, the pump does not start until a falling edge (from logical 1 to logical 0) is measured at the "Remote ON/OFF" input (*Tab. 15 [▶ 26]*/**Pin 7**). The pump is switched off at a rising edge.

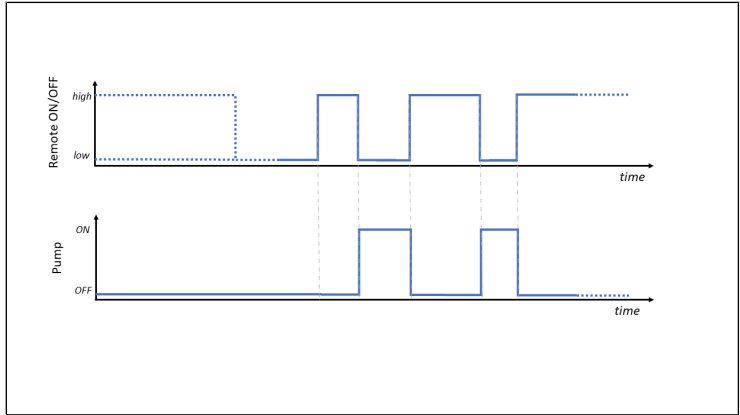

Fig. 7: Analog speed setpoint setting, Pump start: OFF

Starting behavior of pump: TOGGLE (optional)

When the supply voltage to the pump is switched on, the state of the "Remote ON/OFF" is taught in. In this process, the current state of the "Remote ON/OFF" level is defined as the new state for Pump OFF – see figure below.

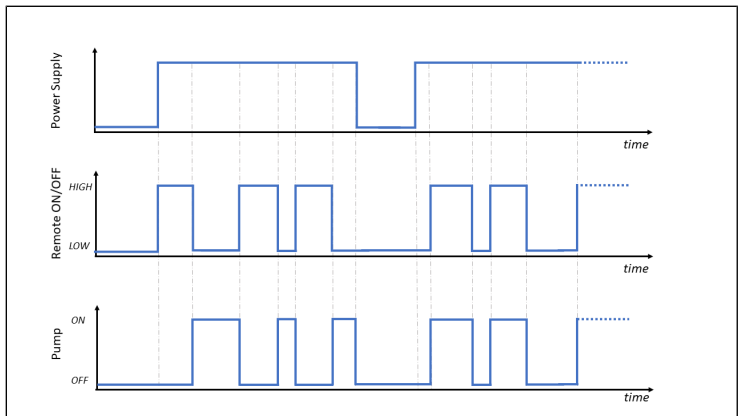

Fig. 8: Analog speed setpoint setting, Pump start: TOGGLE

Starting behavior of pump: LOCAL (optional)

The pump ignores the "Remote ON/OFF" signal. The pump can be stopped by allowing the analog control voltage to fall below its minimum value.

**NOTICE! The optional "Remote RESET" function is disabled for this setting.**



## 8 Servicing

---



### NOTICE

Servicing the pump

Damage to the pumps can result from failure to observe the applicable legal regulations and procedures for the location or intervention by untrained or uninstructed personnel.

- Servicing may only be performed according to the legal regulations (e.g. work safety, environmental protection) and provisions.
- Servicing may only be performed by specialized personnel or trained and instructed personnel.

---

### 8.1 Servicing schedule

---



### WARNING

Risk of explosion if genuine spare parts are not used

If genuine spare parts are not used, the pump loses its explosion protection properties. Furthermore, the function of the pump and its safety are lost. The validity of the conformity is rendered void if genuine spare parts are not used.

- Use only genuine spare parts from KNF when performing maintenance work.
-

Component	Servicing interval
Pump	<ul style="list-style-type: none"> <li>→ Perform periodic inspections for external damage or leakage.</li> <li>→ Periodically check for noticeable changes to noises and vibrations.</li> </ul>
Gas connections	<ul style="list-style-type: none"> <li>→ Perform periodic inspections for external damage or leakage.</li> </ul>

Tab.21:

## 8.2 Cleaning

### 8.2.1 Flushing the pump

When transferring dangerous and environmentally hazardous media, KNF recommends flushing the pump with air at atmospheric pressure for a few minutes prior to switch-off (if necessary for safety reasons: with an inert gas) to extend the service life of the diaphragm.

→ Discharge the media safely.

### 8.2.2 Cleaning the pump

Requirements → Pump disconnected from mains and voltage-free



**CAUTION**

Risk of burns from hot pump parts

The pump head or motor may still be hot after operation of the pump.

→ Allow the pump to cool after operation.

**WARNING**

Health hazard due to dangerous substances in the pump

Depending on the medium being transferred, caustic burns or poisoning is possible.

- Wear protective equipment if necessary, e.g., protective gloves, goggles.
- Clean the pump with suitable measures.

**NOTICE**

During cleaning work, ensure that no fluids enter the interior of the housing.

- Only clean the pump with a dry wiping cloth. When cleaning, use no solvents if possible as these can affect the plastic parts.
- Only use solvents during cleaning if head materials are not corroded (ensure resistance of the material).
- If compressed air is available, blow out the components.

### 8.3 Replacing the diaphragm and valve plates

- Requirements
- Disconnect the drive from the power supply and ensure that it is de-energized.
  - Clean the pump and free the pump of hazardous materials.
  - Remove the hoses from the pneumatic pump inlet and pump outlet.

## Spare parts

Spare part*	Item designation**	Number per pump head
Diaphragm	(1)	1
Heads 1 and 2: Valves	(3)	3
Heads 3 and 4: Valves	(3)	2
Only heads 1 and 2: O-ring (Ø 24 x 2)	(4)	3

Tab.22: \*According to spare parts list, Chapter 9.1 Spare parts [▶ 52]

\*\*see Fig. 11

## Tool and material

Quantity	Tool/material
1	Spare parts set according to spare parts list, Chapter 9.1 Spare parts [▶ 52]
1	Phillips screwdriver no. 2
1	Allen key SW 2.5
1	Allen key SW 3
1	Felt-tip pen

Tab.23:

## Information on the procedure

- Always change the diaphragm and valve plates together so as to maintain the performance and safety of the pump.



## WARNING

Health hazard due to dangerous substances in the pump

Depending on the medium being transferred, caustic burns or poisoning is possible.

- Wear protective equipment if necessary, e.g., protective gloves, goggles.
- Clean the pump with suitable measures.

**CAUTION**

Risk of burns from hot pump parts

The pump head or motor may still be hot after operation of the pump.

→ Allow the pump to cool after operation.

### Disassembling the pump head

1. Disconnect the connection tubing (**2**/Fig. 9) by pressing and holding down the release ring (**1**/Fig. 9).
2. Carefully pull the connection tubing (**2**/Fig. 9) out of the fitting.

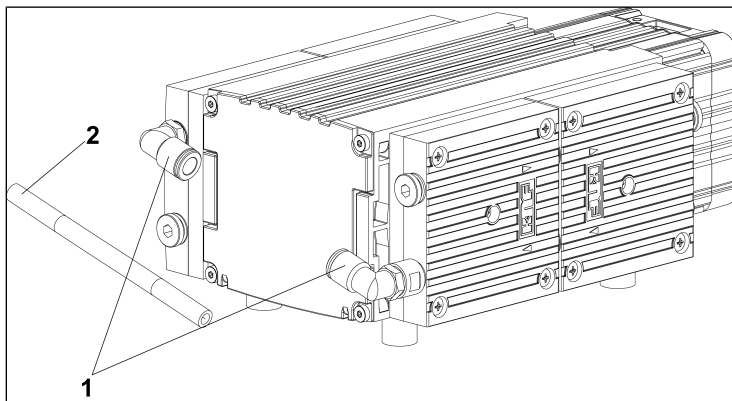
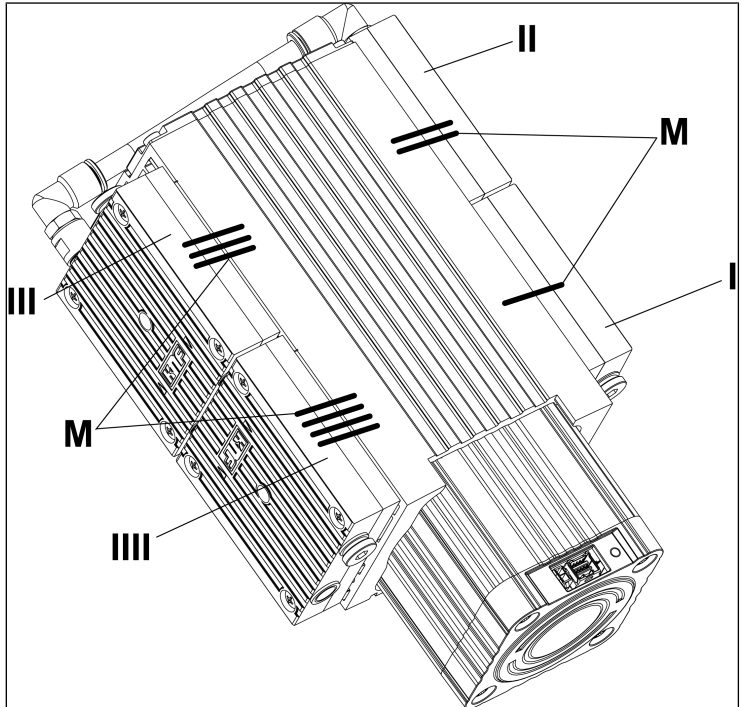

*Fig.9: Disassembly of the connection*

3. Head 1 (I/ Fig. 10):  
Mark the head plate, intermediate plate and compressor housing with a continuous line using a felt tip pen (**M**).
4. Head 2 (II/ Fig. 10):  
Mark the head plate, intermediate plate and compressor housing with two continuous lines using a felt tip pen (**M**).
5. Head 3 (III/ Fig. 10):  
Mark the head plate, intermediate plate and compressor housing with three continuous lines using a felt tip pen (**M**).

6. Head 4 (IIII/Fig. 10):  
Mark the head plate, intermediate plate and compressor housing with four continuous lines using a felt tip pen (**M**).

**i** Marking the various heads helps to avoid incorrect assembly later.



*Fig. 10: Marking of the pump*

7. Loosen the outer 8 fastening screws (7/Fig. 11) of the heads (1 and 2) and remove the heads (1 and 2).

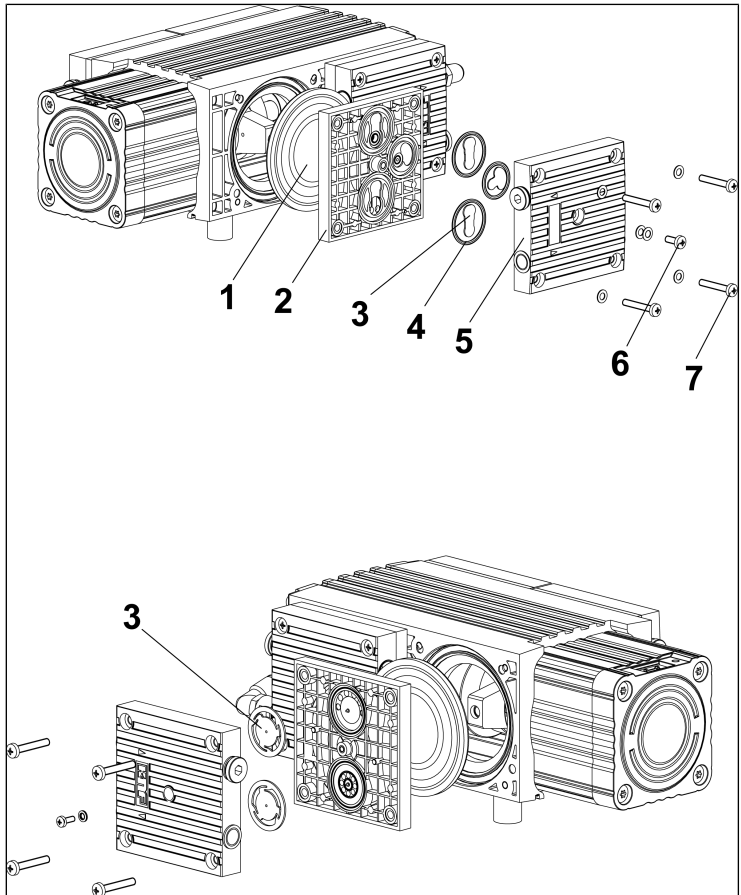

Fig. 11: Exploded view

8. Pull heads 1 (I/ Fig. 12) and 2 (II/ Fig. 12) apart and remove the O-rings (10/ Fig. 12) und (13/ Fig. 12).

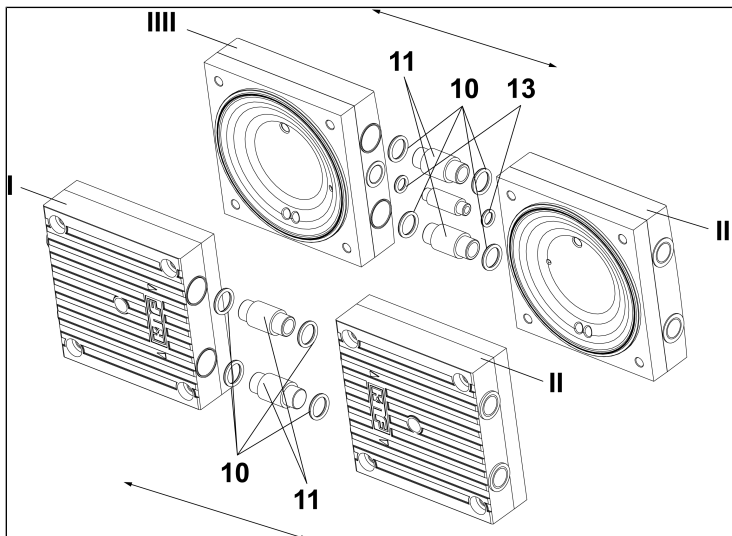

Fig.12: Removal of the O-rings, the connection pipes and the plug

9. On both heads, loosen the head screw (6/ Fig. 13) in the head plate (5/ Fig. 13).
10. Remove the head plate from the intermediate plate (2/ Fig. 13).

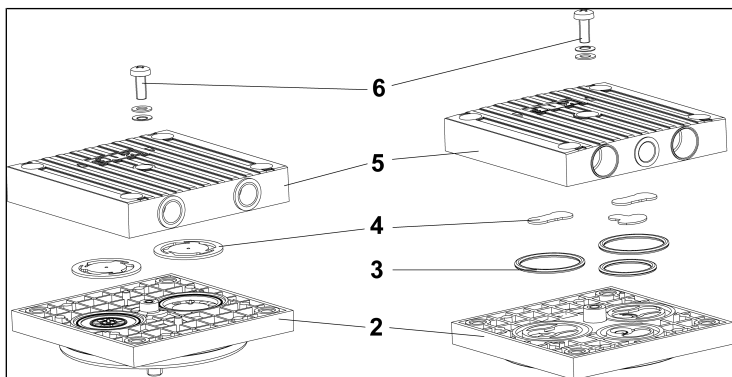

Fig.13: Exploded view of the pump head

### Changing the valve plates and fitting the intermediate plate

1. Remove the valves (4/ Fig. 13) from the intermediate plates (2/ Fig. 13).



2. Only for heads 1 and 2:  
Remove the O-rings (3/Fig. 13).
3. Insert the new valves (4/Fig. 13) in the intermediate plates (2/Fig. 13).
4. Only for heads 1 and 2:  
Insert the new O-rings (3/Fig. 13) in the intermediate plates (2/Fig. 13).

**i** Both sides of the valves are identical.

5. Place the head plates (5/Fig. 13) on the intermediate plates (2/Fig. 13) according to the felt tip pen markings (M/Fig. 10).
6. On both heads, tighten the head screw of the head plate (6/Fig. 13) carefully, lightly and hand-tight (tightening torque: 60 Ncm).

**i** For the arrangement and orientation of the disk springs and washer of the screw, see Fig. 14.

7. Place the O-rings (10/Fig. 12) and (13/Fig. 12) on the connection.
8. Press heads 1 and 2 (I and II/Fig. 12) together.

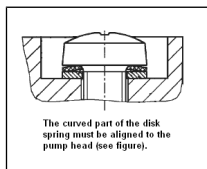

Fig.14: Orientation of the disk spring

### Replacing the diaphragms and fitting the pump head

1. Unscrew the two diaphragms (1/Fig. 15) counterclockwise by hand.

**i** Make sure that the shim rings (12/Fig. 15) located between the diaphragm and the connecting rod do not fall into the pump housing. To ensure pneumatic performance of the pump, make sure to reinstall the exact number of shim rings (12/Fig. 15) as removed.

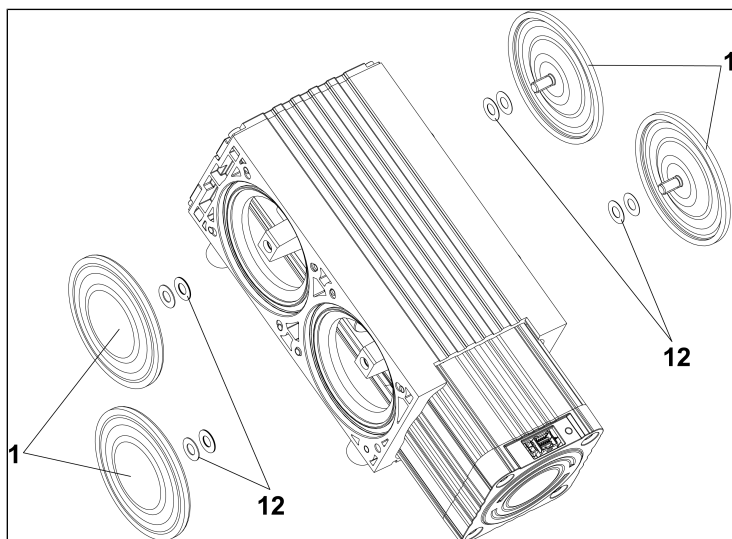

Fig. 15: Diaphragm replacement

2. Screw the new diaphragms (1/Fig. 15) into the thread of the connection rod by hand and tighten them hand-tight.
  - i** If the diaphragm is overtightened, there is risk of the PTFE coating detaching.
  - i** Before the final tightening of the diaphragms, it is recommended that you move the diaphragm to top dead center.
3. Move the diaphragms (1/Fig. 15) to top dead center.
4. Place heads 1 and 2 on the compressor housing and cross-tighten the fastening screws (7/Fig. 11) hand-tight (tightening torque: 3.5 Nm).
5. Perform steps 6-8 (Removing the pump head), as well as steps 1-6 (Replacing the valve plates and fitting the intermediate plates) and steps 1-4 (Replacing the diaphragms and fitting the pump head) for heads 3 and 4 (III and IIII/ Fig. 10).

### Fitting the connection

1. Push the connection tubing (2/Fig. 9) into the fitting as far as it will go.

2. Make sure that the hose connection is secure by pulling gently on the hose.
3. Properly dispose of replaced diaphragms, valve plates and O-rings.

### Final steps

1. Reconnect the suction and pressure line to the pump.
2. Connect the pump to the power supply.

If you have questions with regard to maintenance, please contact your KNF Customer Service (for contact data, visit [www.knf.com](http://www.knf.com)).



### NOTICE

To ensure the required gas tightness of the pump following servicing, a leak test is to be performed.



### WARNING

Risk of injury and poisoning from leaks

- Before recommissioning the pump, check the pump heads and pneumatic connections for leaks. Leaks may lead to poisoning, chemical burns or similar injuries.

## 9 Spare parts and accessories

**i** To order spare parts and accessories, please contact your KNF sales partner or KNF Customer Service (contact data: see [www.knf.com](http://www.knf.com)).

### 9.1 Spare parts

#### Spare part set

A spare part set consists of:

Parts	Item number*	Number per pump head
Diaphragm	(1)	1
Valves (heads 1 and 2)	(3)	3
Valves (heads 3 and 4)	(3)	2
O-ring (D24 x 2) (heads 1 and 2)	(4)	3

*Tab.24: \*See Chapter Replacing the diaphragm and valve plates*

Spare part set	Order number
N952KNDC-B	339257

*Tab.25:*

### 9.2 Accessories

Accessories	Order number
NPT adapter	339159
Small flange	326040
Hose connector	048927
Sealing ring	026906

### 9.3 Motor accessories

Description	KNF order number
<u>Power cable</u> with pre-assembled connector and length of 300 mm	322555
<u>Signal cable</u> with pre-assembled connector and length of 300 mm	346564
<u>RS232 adapter cable</u> with 9-pin S-sub connector	Upon request
<u>UART-USB transceiver cable</u>	Upon request

## 10 Troubleshooting

---



Danger: electric shock can be life-threatening.

- All work on the pump may only be performed by an authorized specialist.
  - Before working on the pump: Disconnect the pump from the power supply.
  - Check and ensure that no voltage is present.
- 

- Allow the pump to cool before troubleshooting.
- Check the pump (see following tables).

<b>Pump not delivering</b>	
<b>Cause</b>	<b>Troubleshooting</b>
Pump is not connected to the electrical mains.	→ Connect the pump to the electrical mains.
No voltage in the electrical mains.	→ Check the circuit breaker for the room and switch it on if necessary.
Pneumatic connections or lines are blocked.	→ Check the connections and lines. → Remove the blockage.
External valve is closed or filter clogged.	→ Check external valves and filters.
Condensation has collected in the pump head.	→ Separate the source of the condensation from the pump. → Flush the pump with air at atmospheric pressure for a few minutes (if necessary for safety reasons: with an inert gas). → Install the pump at the highest location in the system.
Max. voltage range of motor exceeded.	→ Disconnect pump from electrical mains. → The applied voltage must not exceed the value specified in Chapter 6.2 <i>Electrical connection</i> [▶ 22].
Diaphragm and valves are worn or defective.	→ Replace diaphragm and valves (see Chapter 8 <i>Servicing</i> [▶ 41]).

Tab.26:

<b>Flow rate, pressure or vacuum too low</b>	
<b>The pump does not reach the performance stated in the technical data or data sheet.</b>	
<b>Cause</b>	<b>Troubleshooting</b>
Condensation has collected in the pump head.	<ul style="list-style-type: none"> <li>→ Separate the source of the condensation from the pump.</li> <li>→ Flush the pump with air at atmospheric pressure for a few minutes (if necessary for safety reasons: with an inert gas).</li> <li>→ Install the pump at the highest location in the system.</li> </ul>
There is overpressure on the pressure side and at the same time vacuum or pressure above atmospheric pressure on the suction side.	<ul style="list-style-type: none"> <li>→ Change the pneumatic conditions.</li> </ul>
Pneumatic lines or connection parts have insufficient cross-sections or are constricted.	<ul style="list-style-type: none"> <li>→ Disconnect the pump from the system to determine the output values.</li> <li>→ Eliminate any constriction (e.g. valve).</li> <li>→ Use lines or connection parts with a larger cross-section if necessary.</li> </ul>
Leaks occur at pneumatic connections, lines or pump head.	<ul style="list-style-type: none"> <li>→ Eliminate the leaks.</li> </ul>
Pneumatic connections or lines are partially or completely blocked.	<ul style="list-style-type: none"> <li>→ Check the pneumatic connections and lines.</li> <li>→ Remove any parts or particles that are causing blockages.</li> </ul>
Head parts are soiled.	<ul style="list-style-type: none"> <li>→ Clean the head components.</li> </ul>
Working diaphragm broken	<ul style="list-style-type: none"> <li>→ Stop the pump immediately.</li> <li>→ Change the diaphragm (see 8 Servicing [▶ 41]).</li> </ul>
Diaphragm and valves are worn or defective.	<ul style="list-style-type: none"> <li>→ Replace diaphragm and valves (see Chapter 8 Servicing [▶ 41]).</li> </ul>

Tab.27:



<b>Pump exhibiting changed running noises and vibrations</b>	
<b>Cause</b>	<b>Troubleshooting</b>
Pump bearing worn or defective.	<p>→ Determine the cause.</p> <p>→ Contact KNF Customer Service.</p>

Tab.28:

### Display of the errors at the motor controller

Exceeding the overcurrent limit, exceeding the maximum temperature for the motor control board, or blockage of the rotor are displayed as errors.

The manufacturer only provides for logic 1 or 0 via a voltage at the fault output.

To clear the fault, the drive must be disconnected from the supply voltage.

Optional setting:

Upon request, the Remote RESET function can be parameterized by KNF.

### Fault cannot be rectified

If you are unable to identify any of the specified causes, send the pump to KNF Customer Service (contact data: see [www.knf.com](http://www.knf.com)).

1. Flush the pump with air for a few minutes (if necessary for safety reasons: with inert gas) at atmospheric pressure to free the pump head of dangerous or aggressive gases (see Chapter 8.2.1 *Flushing the pump* [▶ 42]).
2. Clean the pump (see Chapter 8.2.2 *Cleaning the pump* [▶ 42]).
3. Send the pump together with completed Health and Safety Clearance and Decontamination Form to KNF, specifying the pumped medium.

# 11 Returns

## Preparing for return

1. Flush the pump with air for a few minutes (if necessary for safety reasons: with inert gas) at atmospheric pressure to free the pump head of dangerous or aggressive gases (see Chapter 8.2.1 *Flushing the pump* [▶ 42]).  
**i** Please contact your KNF sales partner if the pump cannot be flushed due to damage.
2. Remove the pump.
3. Clean the pump (see Chapter 8.2.2 *Cleaning the pump* [▶ 42]).
4. Send the pump together with the completed Health and Safety Clearance and Decontamination Form to KNF, stating the nature of the transferred medium.
5. Pack the device securely to prevent further damage to the product. If necessary, request original packaging for a fee.

## Returns

KNF shall undertake to repair the pump only under the condition that the customer presents a certificate regarding the medium that is pumped and the cleaning of the pump. In this case too, old devices can be returned. Please follow the instructions at [knf.com/repairs here](http://knf.com/repairs).

Contact your KNF sales partner directly if you require additional support for your return service.



KNF Neuberger GmbH  
Alter Weg 3  
79112 Freiburg  
Germany  
Tel. +49 (0)7664/5909-0

E-mail: [info.de@knf.com](mailto:info.de@knf.com)  
[www.knf.com](http://www.knf.com)

## **KNF worldwide**

You can find our local KNF partners at: [www.knf.com](http://www.knf.com)

