

DIAPHRAGM LIQUID PUMP WITH LINEAR DRIVE

FMM 20

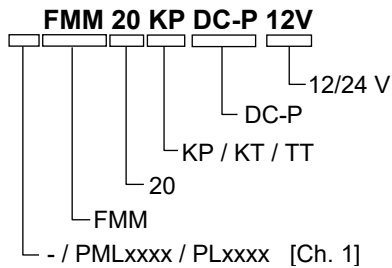

Operating and Installation Instructions

Read and observe these Operating and Installation Instructions!

An additional letter prefixing the FMM model code is a country-specific designation, with no technical relevance.

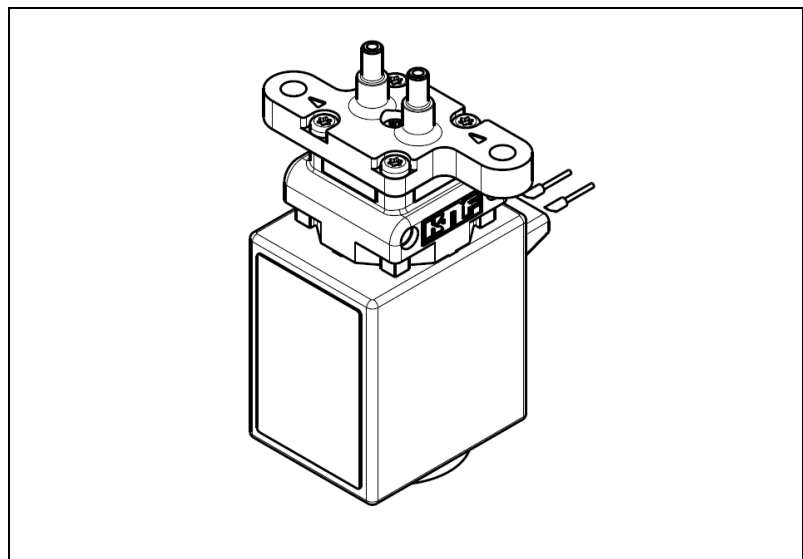

KNF Flodos AG
 Wassermatte 2
 6210 Sursee, Switzerland
 Tel +41 (0)41 925 00 25
 Fax +41 (0)41 925 00 35
 www.knf.com
 info.flodos@knf.com

Contents	Page
1. About this document.....	2
2. Use	3
3. Safety	4
4. Technical data	6
5. Assembly and function	8
6. Installation and connection.....	9
7. Operation.....	13
8. Servicing.....	16
9. Troubleshooting.....	17
10. Accessories and options	19
11. Return of the pump.....	20

1. About this document

1.1. Use of the Operating and Installation Instructions

The Operating and Installation Instructions are part of the pump.

- Forward the Operating and Installation Instructions to any subsequent owners of the pump.

Project pumps

Customer-specific project pumps (pump models which begin with "PL" or "PML") may differ from the Operating and Installation Instructions.

- In the case of project pumps, take note of any additionally agreed specifications.

1.2. Symbols and markings

Warning



WARNING

This symbol indicates a potential danger.

It also indicates the possible consequences of failure to observe the warning. The signal word (e.g. "Warning") indicates the level of danger.

- Here you will see actions for avoiding the danger and potential consequences.

Danger levels

Signal word	Meaning	Consequences if not observed
DANGER	warns of immediate danger	Consequences include death or serious injuries and/or serious property damage.
WARNING	warns of potential danger	Death or serious injuries and/or serious property damage are possible.
CAUTION	warns of a potentially dangerous situation	Minor injuries or damage to property are possible.

Tab. 1

Other information and symbols

- This indicates a required activity (step).
- 1. This indicates the first step of a required activity. Additional consecutively numbered steps follow.

i This symbol indicates important information.

2. Use

2.1. Intended use

The pumps are intended for transferring and metering liquids.

Owner's responsibility

Operating parameters and conditions

Only install and operate the pumps under the operating parameters and conditions described in *Chapter 4*, Technical data.

Only completely installed pumps may be taken into service.

Requirements for transferred medium

Before transferring or metering a medium, check whether the medium can be transferred danger-free in the specific application case.

Before using a medium, check the compatibility of the materials of the pump head, pump housing, diaphragm and valves with the medium.

The temperature of the medium must lie within the permissible temperature range (see *Chapter 4*).

The transferred medium should not contain particles as these can prevent the pump from working correctly. If this cannot be ensured, a < 50 µm filter with a sufficiently large filter area must be used upstream of the pump.

2.2. Improper use

The pumps must not be operated in an explosive atmosphere.

For special modifications outside the standard technical specifications, please contact your KNF technical adviser.

3. Safety

- i** Observe the safety precautions in *Chapters* 6. Installation and connection and 7. Operation.

The pumps are built according to the generally recognised rules of technology and in accordance with the pertinent occupational safety and accident prevention regulations. Nevertheless, dangers may occur during their use which may lead to injuries to the user or others, or to damage to the pump or other property.

Only use the pumps when they are in a good technical and proper working order, in accordance with their intended use, observing the safety advice within the Operating and Installation Instructions, at all times.

Personnel	<p>Make sure that only trained and instructed personnel or specially trained personnel work on the pumps. This especially applies to assembly, connection and servicing work.</p> <p>Make sure that all personnel have read and understood the Operating and Installation Instructions, and in particular the "Safety" chapter.</p>
Working in a safety-conscious manner	Always ensure adherence to all pertinent accident prevention and safety regulations when working on and operating the pump.
Handling dangerous media	When transferring dangerous media, observe the safety regulations for handling such media.
Notes	Always ensure adherence to all information stickers on the pumps, such as flow direction arrows and type plates, and keep stickers in a legible condition.
Environmental protection	All replacement parts should be properly stored and disposed of in accordance with the applicable environmental protection regulations. Ensure adherence to the pertinent national and international regulations. This especially applies to parts contaminated with toxic substances.
Disposal	<p>Dispose of all packaging in an environmentally-appropriate manner. The packaging materials are recyclable.</p> <p>Dispose of end-of-life equipment in an environmentally friendly manner. Use appropriate waste collection systems for the disposal of end-of-life equipment. Used pumps contain valuable recyclable materials.</p>



EU directives/standards	<p>The pumps comply with the fundamental requirements of Directive 2011/65/EU (RoHS2).</p> <p>For the purposes of the Machinery Directive 2006/42/EC, pumps are “partly completed machinery”, and are therefore to be regarded as not ready for use. Partly completed machinery may not be commissioned until such time as it has been determined that the machine in which the partly completed machinery is to be assembled conforms to the provisions of the Machinery Directive 2006/42/EC. The essential requirements of Annex I of Directive 2006/42/EC (general principles) are applied and observed.</p> <p>The following harmonised standards are met (operation with electronic control FE Z3):</p> <ul style="list-style-type: none"><li data-bbox="691 674 1251 705">▪ EN 61000-6-3 (incl. EN 55022 / EN 55011)
Customer service and repairs	<p>All repairs to the pump(s) must be carried out by the relevant KNF customer service team.</p> <p>Only use genuine parts from KNF for servicing work.</p>

4. Technical data

Pump materials

The pump type **KP** stands for:

Assembly	Material ¹⁾
Pump head*	PP
Valve plate	EPDM
Diaphragm	EPDM

Tab. 2

The pump type **KT** stands for:

Assembly	Material ¹⁾
Pump head*	PP
Valve plate	FFKM
Diaphragm	FFKM

Tab. 3

The pump type **TT** stands for:

Assembly	Material ¹⁾
Pump head*	PVDF
Valve plate	FFKM
Diaphragm	FFKM

Tab. 4

¹⁾ According to DIN ISO 1629 and 1043.1

* Pump head 1 (Fig. 1): consists of a connecting plate and an intermediate plate

Hydraulic data FMM 20 DC-P

Parameter	Value
Nominal stroke volume	15 µl ²⁾
Stroke volume calibration range	8 - 17 µl
Flowrate at 20Hz	18 ml/min
Max. permissible pressure	1.0 bar
Flow tight in both directions	0.5 bar
Suction head	>3 mWS ³⁾

Tab. 5

²⁾ During the adjustment of the pump at KNF, ten consecutive strokes are measured. The nominal stroke volume is their average value, which lays between 14.5 and 15.5 µl.

³⁾ At nominal stroke volume.

i Influence of external parameters on accuracy and repeatability.

External parameters, such as hose material, hose length, supply voltage, pulse width, frequency, ambient temperature, viscosity and liquid temperature, have a significant influence on the accuracy and repeatability of the pump.

For more information, please contact your KNF technical adviser.

Specifications FMM 20 DC-P

Rated voltage	12 V	24 V
Maximum operating current	1.45 A	0.6 A
Operating current at 20 Hz (I_{rms})	0.85 A ⁵⁾	0.36 A ⁵⁾
Mean operating current at 20 Hz (I_{mean})	0.67 A ⁵⁾	0.3 A ⁵⁾
Power consumption at 20 Hz	8.04 W ⁵⁾	7.2 W ⁵⁾
Max. permitted frequency	20 Hz ⁵⁾	
ON-time pulse	25 ⁶⁾ ms	
Min. OFF-time pulse	≥ set ON-time	
Leads	AWG24	
EMC Directive	EN 61000-6-3 (incl. EN 55022 / EN 55011)	
Protection class	IP 54	

Tab. 6

⁵⁾ Values at an ON-time of 25 ms.

⁶⁾ Longer ON-time possible, we will be happy to advise you.

**CAUTION**

A longer ON-time may generate a higher operating current, which causes a higher coil temperature.

i For more information about ON-times, contact your KNF technical adviser.

Other parameters

Parameter	Value
Service life	2 billion cycles
Weight	88 g ⁷⁾
Stroke volume setting	Allen key 1.5 mm
Permissible kinematic viscosity of medium	≤ 150 cSt

Tab. 7

⁷⁾ The weight may differ slightly from the stated value, depending on the version.

Ambient conditions

Parameter	Value
Permissible ambient temperature	+ 5 ¹¹⁾ to + 40°C
Permissible media temperature	+ 5 ¹¹⁾ to + 80°C

Tab. 8

¹¹⁾ KT and TT versions can be operated to 5°C by specifically adjusting the operating parameters. We will be happy to advise you. .

5. Assembly and function

Assembly

- 1 Outlet
- 2 Inlet
- 3 Connecting plate
- 4 Drive
- 5 Connecting leads
- 6 Intermediate plate

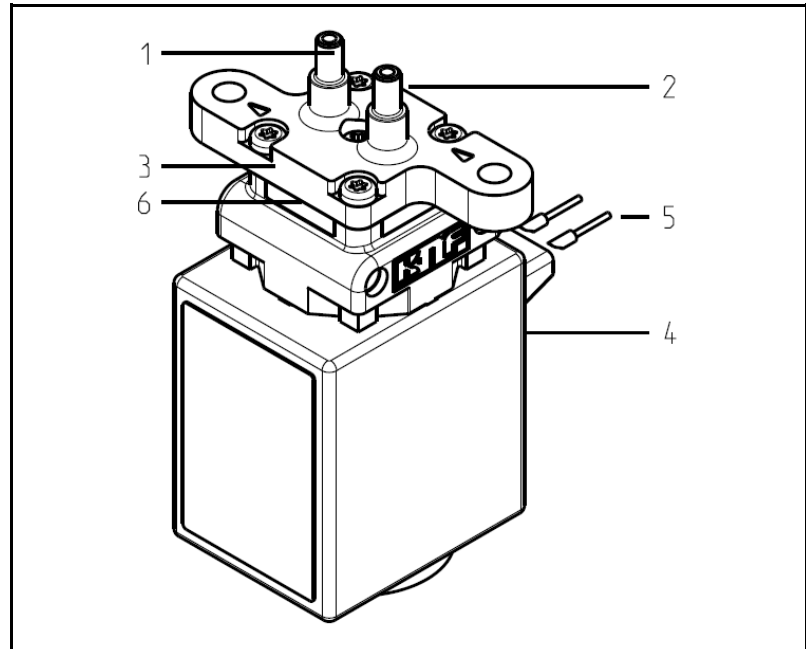

Fig. 1: Magnetic diaphragm metering pump FMM 20

- 1 Outlet valve
- 2 Inlet valve
- 3 Diaphragm
- 4 Spring
- 5 Anchor
- 6 Magnetic coil
- 7 Calibrating screw

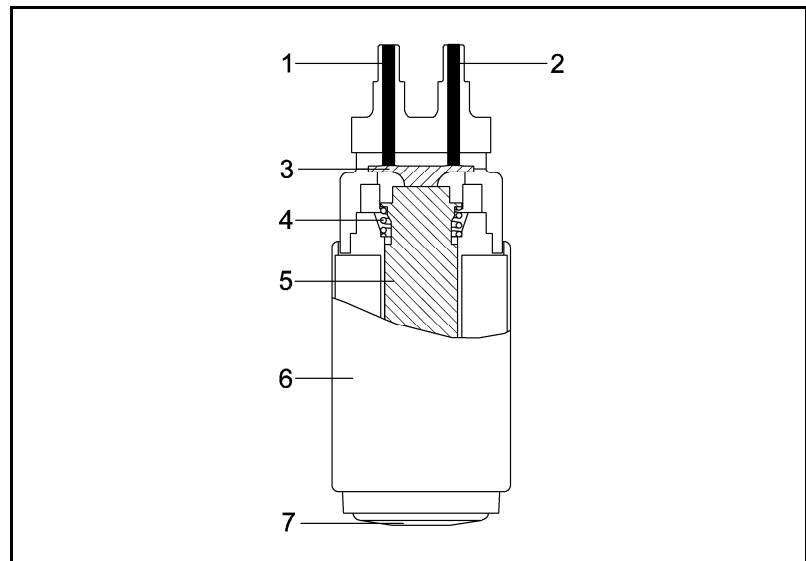

Fig. 2: Pump assembly

Supplying the magnetic coil with the specified electrical voltage (see Chapter 4) produces a magnetic field. This magnetic field pulls the anchor (5) and the attached diaphragm (3) back to an adjustable limit stop. This causes the diaphragm chamber to be filled with the transferred medium via the inlet (2). In the upward stroke the spring tension on the diaphragm forces the medium out of the pump head via the outlet (1). Once the upward stroke is completed, the spring (4) pushes the diaphragm into the diaphragm chamber until the next pulse. This closes the suction and pressure lines. The stroke volume of the pump can be adjusted via the limit stop. The height of the limit stop is adjusted by turning the calibrating screw (7).

6. Installation and connection

Install the pumps only under the operating parameters and conditions described in *Chapter 4*, Technical data.

Observe all safety precautions (see *Chapter 3*).

6.1. Installation

- Before installation, store the pump at the installation location to bring it up to ambient temperature.
- Mounting dimensions (see Fig. 3)

Mounting dimensions

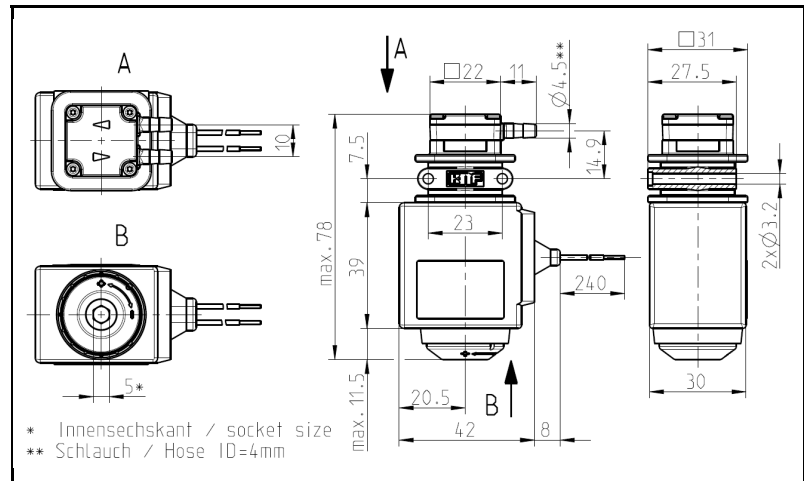

Fig. 3: Mounting dimensions FMM 20

- Installation location → Make sure that the installation location is dry and the pump is protected against water in the form of rain, spray, splashes and drips.
- Protect the pump against dust.
- Protect the pump against vibration and impact.
- Installation position → Generally speaking, the pump can be installed in any position. For maximum precision and rapid venting, install pump as shown in the illustration (Fig. 4).

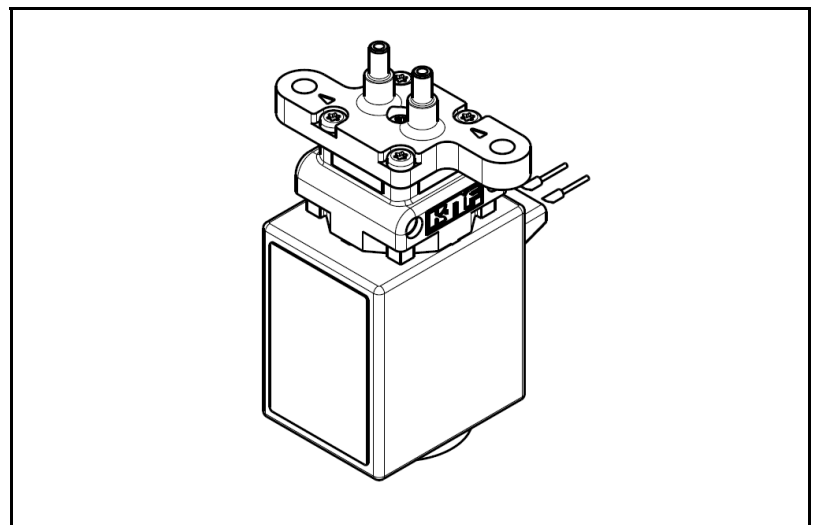

Fig. 4: Optimum installation position

6.2. Electrical connection

- Only have the pump connected by an authorised specialist.
- Only have the pump connected when the power supply is disconnected.
- A Si diode is recommended as an extinguishing diode.
- The electrical installation must be fitted with a device that disconnects the magnetic coil from the mains (acc. to EN 60335-1).
- When connecting the device to a power source, the relevant norms, directives, regulations and technical standards must be observed.

Connecting the pump

1. Make sure that the power supply data match the data on the coil type plate. The operating current can be found on the type plate.
 - i** The supply voltage must not deviate more than $\pm 10\%$ from the specifications on the type plate.
2. Connect the voltage supply cables to the two pump leads.
 - i** The polarity is irrelevant.



CAUTION

- Do not connect the pump to a continuous direct voltage. Information on the control signal (see *Chapter 7*).
-

6.3. Hydraulic connection

- Connected components → Only connect components to the pump that are designed to handle the hydraulic data of the pump.
- Hoses → Only use hoses that are suitable for the maximum permissible operating pressure of the pump.
- Only use hoses that are sufficiently chemically resistant to the liquids being transferred.

The hydraulic connection can be made using hoses (*Section 6.3.1*) or a flange (*Section 6.3.2*). Further connection options may be available, depending on the project (*Chapter 10.1*).

6.3.1. Connecting the pump

- i** Arrows on the pump head indicate the flow direction.
1. Remove the protective caps.
 2. Connect the suction and pressure lines.
 3. If the pump is used to build up pressure, make sure that all transition joints between hose and pump are secure in order to ensure that the hoses cannot come off.
 4. Check that the hoses and transition joints are fitted correctly and securely.
 5. Check that the system is leak-tight.

6.3.2. Connecting the pump via a flange

- As shown in the assembly diagram (Fig. 5), the pump is mounted on the flange (2) and sealed with O-rings (1).
- The flange is connected to the connecting plate as shown in the connection diagram (Fig. 6).
- Ensure compliance with the required tolerances when setting up the connecting plate.
- O-ring and flange material must be sufficiently resistant to the chemicals being transferred.
- O-rings can be ordered from KNF (*Chapter 10*).

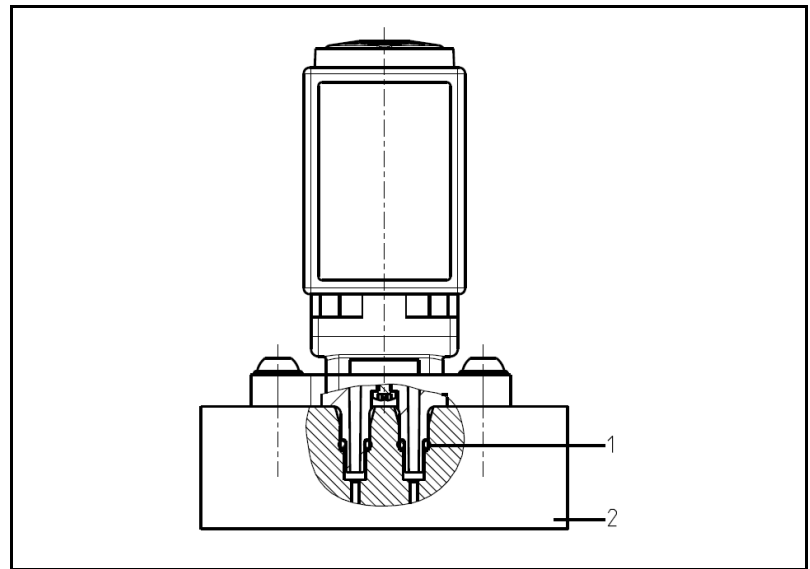

Fig. 5: Assembly diagram

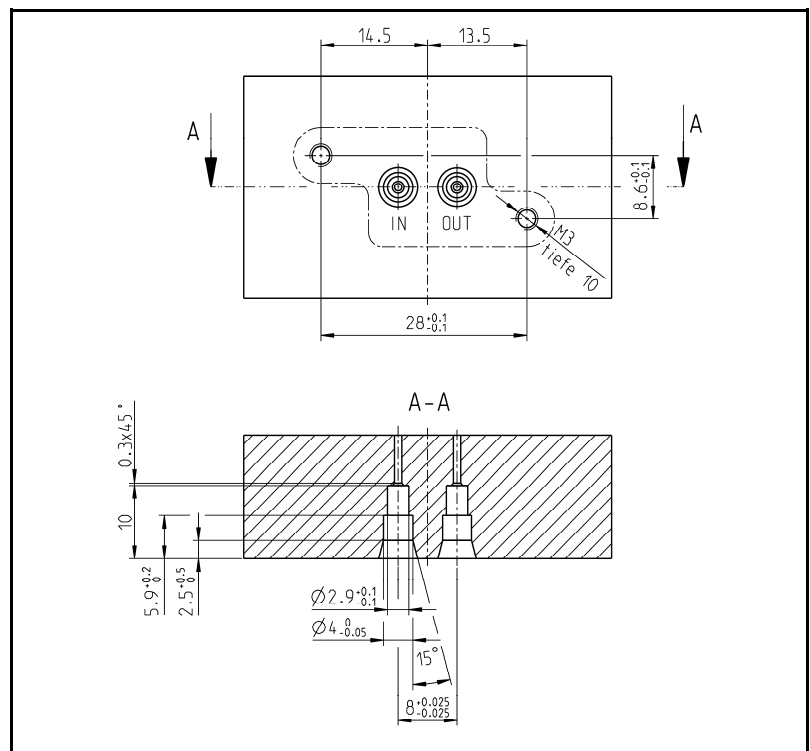

Fig. 6: Connection diagram

7. Operation

7.1. General points

- Operate the pumps only under the operating parameters and conditions described in *Chapter 4*, Technical data.
- Ensure that the pumps are being used correctly (see *Chapter 2.1*).
- Avoid improper use of the pumps (see *Chapter 2.2*).
- Observe all safety precautions (see *Chapter 3*).
- The pumps are components that are intended to be incorporated into another machine. Before putting them into service it must be established that the machinery or systems in which they are installed meet the relevant regulations.



CAUTION

Risk of burning

The magnetic coil of the pump heats up

- Avoid contact with the magnetic coil of the pump.
- Avoid contact with flammable materials.



WARNING

Danger of bursting of the fluid system due to overpressure.

The pump builds up pressure. A closed system can cause the max. permitted operating pressure to be exceeded. This can cause injuries or damage to the pump and the system.

- Avoid operation against a closed system.
- Only use wetted parts that are rated for at least the operating pressure of the pump.
- If necessary, limit the maximum system pressure by suitable measures.

- i** Excessive pressure and the inherent dangers thereof can be prevented by placing a bypass line with a pressure relief valve between the pressure and suction side of the pump. For further information, contact your KNF technical adviser (telephone number: see first page).

Pump standstill

- If the pump stops running, restore the system to normal atmospheric pressure.

Switching on the pump

- In order to ensure that the pump starts every time, make sure that counterpressure is reduced to an acceptable level before start-up. This should also be done during operation after a brief power cut.

i For more specific information contact your KNF technical adviser.

Switching off the pump

- KNF recommends: if transferring aggressive liquids, the pump should be flushed thoroughly prior to switch off (see Section 8.2.1), as this will help to extend the service life of the diaphragm.
- Restore the system to normal atmospheric pressure (release hydraulic pressure in pump).

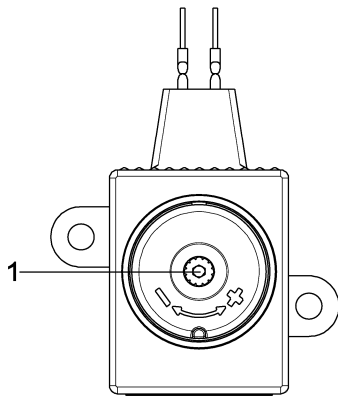

Fig. 7 Adjusting the stroke

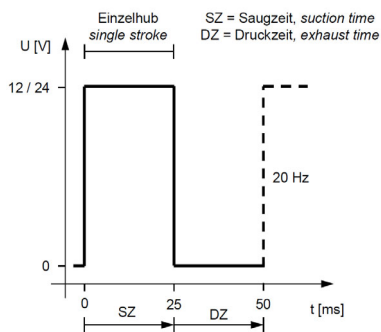

Fig. 8: Single stroke

7.2. Adjusting the stroke volume

The stroke volume, and thus the metering volume of the transferred media, can be adjusted by turning the calibrating screw (see Fig. 7, Pos. 1) at the bottom of the pump.

Calibration range of metering volume per pump stroke: 8 – 17 μl .

i A 1.5 mm Allen key is required to adjust the stroke.

7.3. Executing single strokes

When the voltage is applied, the pump sucks in liquid (one stroke, see Fig. 8). When the voltage is removed, the previously sucked-in liquid is ejected.

i For operational purposes, the suction time, i.e. the time that the magnetic coil is energised, should be at least 25 ms.

7.4. Executing several strokes

The stroke frequency can be adjusted via the voltage frequency.

Frequency range: 0 to 20 Hz.

7.5. Adjusting the flow rate

The flow rate can be adjusted via the stroke volume (*Chapter 7.2*) or by means of the stroke frequency (*Chapter 7.4*).

i For reasons of accuracy, we recommend keeping the suction time, or the energised time (SZ), as constant as possible and adjusting the stroke frequency via the exhaust time (DZ).

i The pumps are checked and set to a suction/energised time of 25 ms by KNF Flodos.

8. Servicing

8.1. Servicing schedule

i *Customers must not open the pump.* For more specific information contact your KNF technical adviser.

Component	Servicing interval
Pump	- Regular inspection for external damage or leaks
Pump head	- Clean if the flow rate decreases, the pump does not work or no vacuum is created (<i>Chapter 8.2</i>).
Diaphragm and valve plates	- Change as soon as pumping capacity decreases, preferably sooner

Tab. 9

8.2. Cleaning

Information on procedure



WARNING

Health hazard due to dangerous substances in the pump

Depending on the medium transferred, caustic burns or poisoning are possible.

→ Wear protective clothing if necessary, e.g. protective gloves.

→ Flush the pump with a neutral liquid and pump empty.

8.2.1. Flushing the pump

→ When transferring aggressive media, KNF recommends flushing the pump with air (or an inert gas if necessary for safety reasons) under atmospheric conditions for a few minutes before switching off in order to extend the service life of the diaphragm.

8.2.2. Cleaning the pump

→ Where possible, wipe the solenoid and pump head with a dry cloth. Do not use cleaning solvents as these may corrode plastic parts.

9. Troubleshooting

- Disconnect the pump from the power supply before working on the pump.
- Ensure that there is no power.

Stroke not executed	
Possible cause	Remedy
Pump not connected to power supply	→ Connect pump to power supply
Power supply is not switched on	→ Switch on power supply
Connecting leads are damaged	→ Check connecting leads for damage → Check connecting lead entry on solenoid for damage
Connections or hoses are blocked	→ Check connections and hoses → Remove blockage
External valve is closed or filter is blocked	→ Check external valves and filters
Incorrect interchange of pressure and suction line connections	→ Remove pressure and suction lines and reconnect correctly
Pressure on the pressure side is too high	→ Reduce the pressure on the pressure side of the pump
Electrical signal is outside the defined range	→ Adjust pulse signal (see <i>Chapter 7</i>)

Tab. 10

Pump is not priming	
Possible cause	Remedy
Suction side of pump not connected	→ Connect the suction side of the pump
Liquid in the container is too low	→ Fill container
Hose connections are not leak-tight	→ Secure transition joints between hose and connections with clamps or other clamping elements
Peripheral valve is closed or filter is clogged	→ Open the peripheral valve → Clean filter
Particles in the pump	→ Contact KNF
The pump parts are not resistant to the medium to be transferred	→ Replace the pump with a compatible head version (Contact KNF)
Pressure and suction lines were connected incorrectly	→ Remove pressure and suction lines and reconnect correctly

Tab. 11

Stroke volume, suction head or pressure head is too low	
The pump does not achieve the performance that the customer expects.	
Possible cause	Remedy
Components in the system connected to the suction and pressure sides, such as hoses, valves or filters, are causing too much resistance	→ Modify installation
Hose connections are not leak-tight	→ Secure transition joints between hose and hose connections with clamps or clamping elements
Particles in the pump	→ Contact KNF
Viscosity of the transferred medium is too high	→ Contact KNF
Incorrect interchange of pressure and suction line connections	→ Remove pressure and suction lines and reconnect correctly
The pump parts are not resistant to the medium to be transferred	→ Replace the pump head with a compatible version (Contact KNF)

Tab. 12

Fault cannot be rectified

If you are unable to identify any of the above causes, please send the pump to KNF customer service (see address on last page).

1. Flush the pump to clear the pump head of any hazardous or aggressive liquids (see *Section 8.2.1*).
2. Dismantle the pump.
3. Clean the pump (see *Section 8.2.2*).
4. Send the pump, with completed decontamination declaration (see *Chapter Fehler! Verweisquelle konnte nicht gefunden werden.*), to KNF stating the nature of the transferred medium.

10. Accessories and options

Accessories

Accessories	Order No.
O-ring EPDM 2.5 x 1	157604
O-ring FFKM 2.5 x 1	157734
Electronic module FE Z3	157640
Filter FS 25 T	346935 (1 piece); 346936 (10 pcs.)
Filter FS 25 X	346941 (1 piece); 346942 (10 pcs.)
Filter FS 60 T	346932 (1 piece); 346933 (10 pcs.)
Filter FS 60 X	323625 (1 piece); 323626 (10 pcs.)

Tab. 13

10.1. Alternative methods of connection (optional)

Depending on the respective project, the head parts are available with the following methods of connection:

- UNF-1/4" thread (Fig. 9)
- Hose connector (Fig. 10)
- Flange fixture with O-ring (Fig. 11)

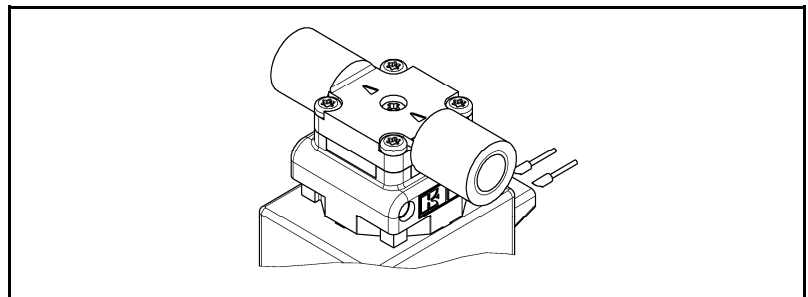

Fig. 9: Pump head with UNF-1/4" thread connection

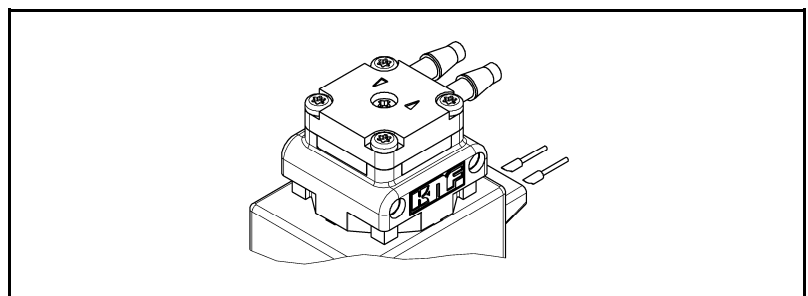

Fig. 10: Pump head with hose connection

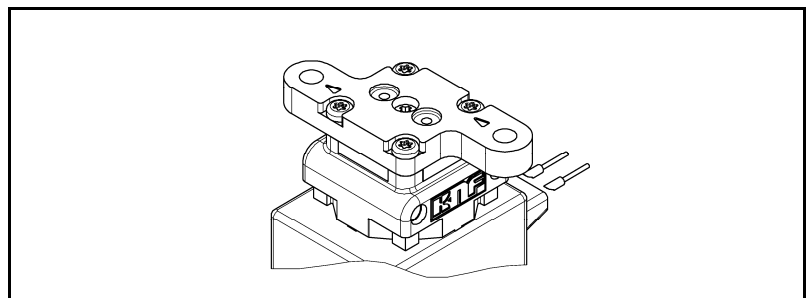

Fig. 11: Pump head with flange-mounted connection

11. Return of the pump

i KNF undertakes to repair the pump only under the condition that the customer provides a certificate of the pumped medium and cleaning of the pump. For this purpose, please follow the instructions on www.knf.com/repairs.

Please contact your KNF sales representative directly if you need additional support for your return service.

KNF worldwide

Please find your local KNF partners at: www.knf.com

