

# UFK 1.1100 EX DIAPHRAGM LIQUID PUMP



UFK 1.1100 KT .27 I EX

## ADVANTAGES

- Class 1, Div 1, Groups C&D
- High pressure with integrated pressure relief valve
- Low pulsation
- Excellent linearity of flow vs load
- High chemical resistance
- Self-priming
- Can run dry continuously
- Food grade materials available \*

## POSSIBLE AREAS OF USE

- Solvent transfer
- Extraction
- Oil & gas
- Chemical
- Pharmaceutical processes

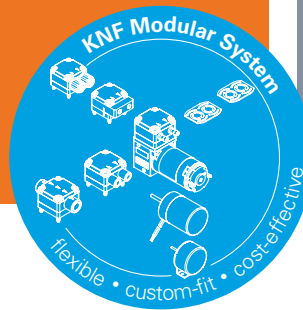

Please visit our website  
[www.knf.com](http://www.knf.com)  
to get more information

## PERFORMANCE DATA

Series model	UFK 1.1100		
Material options	KT .27 I Ex		
Pump head: connection plate	PP		
Pump head: intermediate plate	PPS		
Diaphragm	PTFE		
Valves	FFKM		
Resonating diaphragm	FKM		
Flow rate at atm. pressure (l/min)	11.5		
Suction height (mH <sub>2</sub> O/ftH <sub>2</sub> O)	4/13		
Pressure head (mH <sub>2</sub> O/psig)	60/85		
Permissible ambient temperature (°C / °F)	5 - 60 / 41 - 140		
Permissible liquid temperature (°C / °F)	5 - 80 / 41 - 176		
Weight (kg/lbs)	18/40		
IP protection factor	54		

## ELECTRICAL DATA

Operating voltage, frequency (V), (Hz)	115/230, 60		
Power consumption (W)	750		
I max. Start (A)	6.5/3.3		
HazLoc rating, temperature code & certifications	Class 1, Div 1, Groups C&D	T3B	UL / CSA

\* food grade conformity according to the standard NSF/ANSI 169

# UFK 1.1100 KT .27 | EX

## PERFORMANCE DATA

Series model	Flow rate at atm. pressure (l/min)	Max. suction height (mH <sub>2</sub> O/ftH <sub>2</sub> O)	Max. pressure head (mH <sub>2</sub> O/psig)
UFK 1.1100 KT .27   EX	11.5	4/13	60/85

## UFK 1.1100 KT .27 | EX

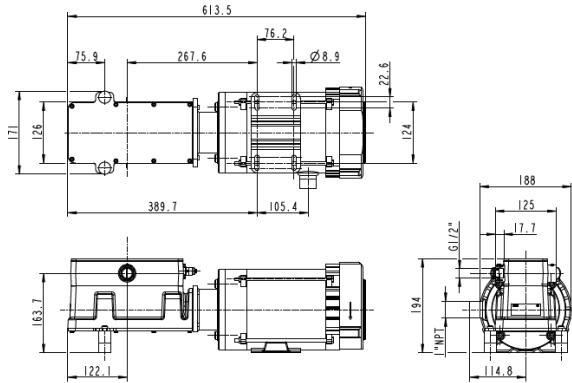



Dimensions in mm

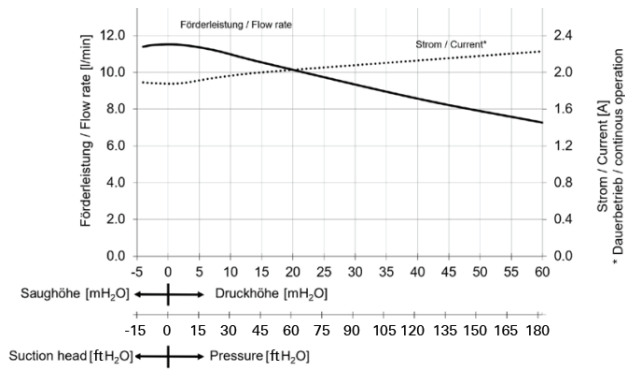

## UFK 1.1100 KT .27 | EX FLOW CURVE



## OPTIONS

Description	Illustration	Part No.	Details
Pressure relief valve - comes standard with HazLoc version			Passive diaphragm valve to protect the pump from pressure peaks on the outlet. The required pressure can be set by a spindle/spring combination.
Other diaphragm materials			Following additional material is available:  EPDM
Certification - National Sanitary Foundation			Optional certification confirms wetted materials of pump approved for use with food/consumables per NSF/ANSI 169

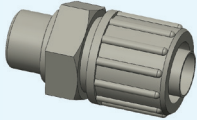
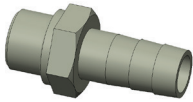
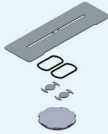
## ACCESSORIES

Description	Illustration	Part No.	Details
Compression fitting		176189	Connection for flexible tubes suitable for higher pressures. Connection: DN16/22 (5/8" / 7/8") Material: PP O-Ring (included): FKM
Hose connector		178172	Straight hose barb suitable for lower pressures. Connection: DN16 (5/8") Material: PP O-Ring (included): FKM
Spare Parts Set "small"		177999	Contains following elastomer parts: 1 pc. Diaphragm 2 pcs. Anchor valves 2 pcs. O-rings 1 pc. Resonating diaphragm
Spare Parts Set "large"		178001	Contains following elastomer parts: 3 pcs. Diaphragms 6 pcs. Anchor valves 6 pcs. O-rings 1 pc. Resonating diaphragm

The performance values for the series models shown on this data sheet were determined under test conditions. The actual performance values may differ and depend in particular on the usage conditions and therefore on the specific application, on the parameters of the components involved in the user's system and on any technical modifications carried out which deviate from the standard configuration or the as delivered condition.

If individual designs have been created for specific customers on the basis of series models, other technical performance data may apply.

Before operation begins, the relevant operating instructions and/or assembly or installation instructions should be read and the safety information contained in these instructions should be noted. KNF reserves the right to make changes to the product and the associated documentation without prior notice to the customer.



[www.knf.com](http://www.knf.com)