



# UFK 1.1100 EX

INSTALLATION INSTRUCTIONS

# DIAPHRAGM PUMP



**KNF Neuberger, Inc**  
2 Black Forest Rd  
Trenton NJ 08691-1810  
609-890-8600

[www.knfusa.com](http://www.knfusa.com)

Ident#337361/337364  
Revision (03/22)

Before operating the pump and the accessories, please read the Installation Instructions and safety precautions.

<b>Table of contents</b>		<b>Page</b>
<b>1</b>	<b>General .....</b>	<b>3</b>
1.1	Information about the instructions	3
1.2	Warnings	3
1.3	Disclaimer	4
1.4	Manufacturer's address	4
1.5	Supporting documents	4
<b>2</b>	<b>Safety .....</b>	<b>5</b>
2.1	Intended use	5
2.2	Reasonably foreseeable misuse	5
2.3	Responsibility of the user	5
2.4	Product-specific risks	5
2.5	Customer service and repairs	7
<b>3</b>	<b>Installation .....</b>	<b>8</b>
3.1	Installation location	8
3.2	Mechanical mounting	8
3.3	Connecting the fluid system	9
3.4	Electrical connection	9
<b>4</b>	<b>Initial start-up .....</b>	<b>11</b>
<b>5</b>	<b>Maintenance .....</b>	<b>13</b>
5.1	Cleaning	13
5.2	Preparing for dismantling	14
5.3	Dismantling the pump head	15
5.4	Assembling the pump head	16
<b>6</b>	<b>Overpressure protection .27 .....</b>	<b>18</b>
6.1	Dismantling and cleaning	18
6.2	Assembling	18
<b>7</b>	<b>Rectifying transfer problems .....</b>	<b>20</b>
<b>8</b>	<b>Spare parts .....</b>	<b>21</b>
<b>9</b>	<b>Returning the pump .....</b>	<b>22</b>

## 1 General

### 1.1 Information about the instructions

Content	The Installation Instructions describe the requirements for installing the product correctly and safely into the complete machine.
Storage location	These Installation Instructions are a part of the product. The safety-relevant information should be taken over for the documentation of the complete machine.
Project pumps	With customer-specific project pumps (pump types which begin with "PU" or "MPU"), there may be differences from the Installation Instructions.

### 1.2 Warnings

Warnings in the Installation Instructions are marked by the hazard symbol, the keywords, and the color. These features provide information about the extent of the hazard.



#### **⚠ DANGER**

This indicates a dangerous situation that will directly cause death or serious injury if not prevented.



#### **⚠ WARNING**

This indicates a dangerous situation that may cause death or serious injury if not prevented.



#### **⚠ CAUTION**

This indicates a dangerous situation that may cause moderate or slight injuries if not prevented.

#### **NOTICE**

This indicates a situation that may cause damage to property if not prevented.

### 1.3 Disclaimer

The manufacturer accepts no liability for damage or malfunctions that are caused by non-compliance with the Installation Instructions.

The manufacturer accepts no liability for damage or malfunctions that are caused by modifications to or conversions of the device or by improper handling.

The manufacturer accepts no liability for damage or malfunctions that are caused by using spare parts or accessories that are not approved by the manufacturer.

### 1.4 Manufacturer's address

KNF Neuberger, Inc.  
2 Black Forest Rd.  
Trenton, NJ 08691

Phone (609) 890-8600

Fax (609) 890-8323

[www.knf.com](http://www.knf.com)

### 1.5 Supporting documents

The listed documents must also be observed. The valid versions are available at [www.knf.com/en/us/service/downloads](http://www.knf.com/en/us/service/downloads).

- Data sheet
- 3D model

The following must also be observed:

- Local T&Cs
- Sales documents and agreement between KNF and the customer
- Drive specification

## 2 Safety

### 2.1 Intended use

The pump is intended solely for the following uses:

- Transferring liquids and gases
- For operation in accordance with the operating parameters specified in the technical data of the supporting documents

### 2.2 Reasonably foreseeable misuse

The pump must not be used to transfer media whose compatibility with the pump head, valves, diaphragm, and seals has not been proven.

### 2.3 Responsibility of the user

The user is responsible for ensuring that the safety precautions in these Installation Instructions are complied with. Applicable safety, accident prevention, and environmental protection regulations must be complied with.

### 2.4 Product-specific risks

Remaining risks that were determined in a risk assessment are described in this section. Safety precautions and warnings in this section and in the other sections of the Installation Instructions must be observed to prevent dangerous situations.



## ⚠ DANGER

### **Danger of injuries and damage to property due to dangerous substances**

Poisoning and chemical burns or unintended reactions caused by leaking dangerous substances

- Observe the safety data sheets of the transferred media.
- Before transferring a medium, check whether it can be transferred safely in the specific application case.
- Ensure that the system is not subject to any risks of explosion – not even under extreme operating conditions (temperature, pressure) or in case of malfunctions.
- Ensure the pump is used only by suitably trained, skilled employees.
- Clarify the chemical resistance of the head materials.
- Check that the pump and the system do not leak at the operating temperature of the transferred medium.
- Check the pump for damage regularly.
- Operate the pump only when you are sure it has no technical malfunctions.
- Operate the pump in accordance with the technical data.
- Work on the pump or fluid circulation system only after they have been decontaminated and/or a decontamination declaration is present.

## ⚠ DANGER

**Danger of injuries and damage to property due to leaks at the interfaces to the pump head**

Poisoning and chemical burns or unintended reactions caused by leaking dangerous substances

- Wear personal protective equipment.
- Connect the pump correctly.
- Operate the pump only when you are sure it has no technical malfunctions.
- Operate the pump in accordance with the technical data.



**⚠ DANGER**

**Danger of injuries and damage to property due to uncontrolled flow while the pump is not in operation**

Poisoning and chemical burns or unintended reactions caused by leaking dangerous substances

- Construct the fluid system so that the operating pressure at the pressure side of the pump is higher than at the suction side.
- Install a shut-off valve in the fluid circulation system.

The risk analysis indicates a risk of explosion from materials and substances.



**⚠ DANGER**

**Danger of injuries and damage to property due to an explosion in the pump**

The pump housing is made from aluminum. If the pump diaphragm is damaged, medium can accumulate in the housing and form hydrogen (especially with acids and lyes). This could cause an explosion in the pump housing.

- Check and monitor the reactivity of the medium with aluminum.

The pump housing is designed to withstand pressure surges caused by explosions. The probability of a fault that would cause an explosion is deemed to be low. When installed in the system, the risks in the complete system must be assessed.



**⚠ DANGER**

**Danger of injuries and property damage caused by an explosion in the connection lines and in the pump**

Evaporation of flammable liquids

- When flammable liquids are transferred, an explosive atmosphere can form in the pump and in the lines during filling and emptying.
- With the hoses that are used, pay attention that no electrostatic charges can form (use conductive materials, grounding and potential equalization).
- The hoses and piping that are used must be able to withstand the expected pressure of explosion.



**⚠ DANGER**

**Danger of injuries and property damage caused by the pump exploding**

If the pump has not been used or has been stored for some time, residual medium may evaporate and, together with oxygen, form an explosive atmosphere.

- If the pump has not been used for some time or is stored, empty the pump and rinse with neutral medium to prevent a subsequent reaction.



**⚠ WARNING**

**Danger of injuries and property damage caused by leaks to the environment**

Flammable materials

- Keep flammable materials away from the direct vicinity of the pump and piping.

## 2.5 Customer service and repairs

All repairs to the pumps must be carried out by the responsible KNF service team.

Use only genuine parts from KNF for servicing work.

### 3 Installation



#### ⚠ WARNING

##### **Danger from incorrect installation**

Injuries or damage to property from leaking media

- After installation, check the system for leaks with a safe medium.
- Observe the requirements for intended use.
- Take precautions in the design of the end device so that leaking liquids cannot come into contact with live components.
- Use only connections that are specified in the data sheet. Do not use NPT threads or sealing tape, as cracks can occur at the plastic connections.

The following requirements apply to all activities described in this section:

#### 3.1 Installation location

The installation location must:

- protect the pump against immersion
- keep aggressive and flammable liquids and vapors away
- allow hoses to be connected without tensile or bending stress
- take account of cooling the pump drive
- ensure that any leaks can be handled
- have appropriate precautions if flammable media are used

#### 3.2 Mechanical mounting

- Protect the product against impacts, knocks, and strong vibrations.
- Please refer to the product data sheet for dimensions, installation positions, and fluid connections.



#### ⚠ CAUTION

##### **Danger due to loss of stability**

Injuries caused by the pump toppling over

- Wear safety shoes with steel caps.
- When the pump is installed in the machine, secure it with screws or clamps.
- When attaching accessories, make sure that the pump cannot topple over.



### 3.3 Connecting the fluid system

Use suitable means to check the fluid connection for leaks.  
For more information regarding dimensions, please refer to the data sheet.

### 3.4 Electrical connection

For terminal assignment, output data, and control requirements, please refer to the data sheet.

Observe the regulatory requirements for electrical installations:

- Overload protection and separating protective devices
- Contact protection and additional insulation
- Ground connections
- Protection against vibrations, tensile stress, and corrosion



#### ⚠ WARNING

##### Danger of electric shock

If the pump is not installed correctly, there is a risk of electric shock.

- The electrical installation of the pump must be carried out by a trained specialist who has relevant credentials.

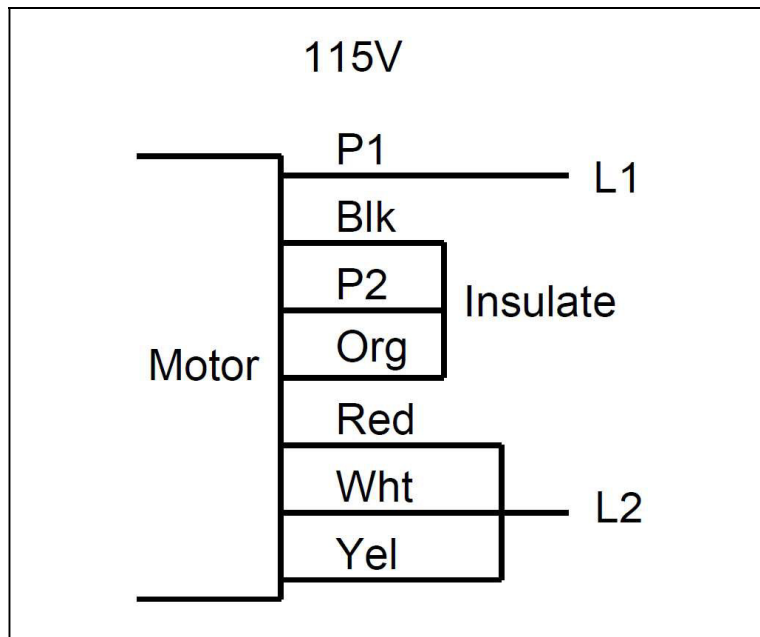

Fig. 1: 115V Connection

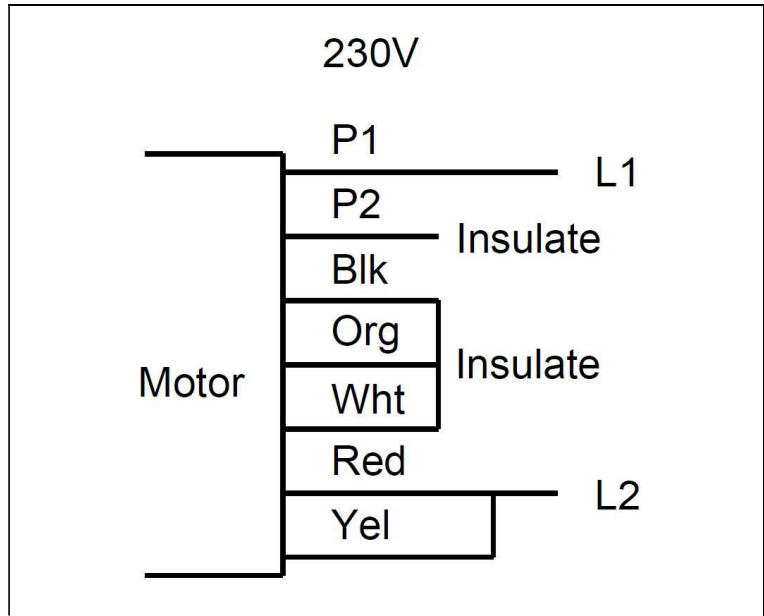

Fig. 2: 230V Connection

## 4 Initial start-up

The product must not be started up until it has been ensured that the machine in which the product is to be installed meets the requirements of the Machinery Directive 2006/42/EC, if applicable.



### **WARNING**

#### **Danger that the fluid system could rupture due to excess pressure**

The pump builds up pressure. With a closed system, the max. permitted operating pressure can be exceeded. This may cause injuries to personnel, or damage to the pump or the system.

- Prevent operation against a closed system.
- In the case of parts that are in contact with the fluid, use only those that are designed to withstand at least the operating pressure of the pump.
- If necessary, take suitable measures to limit the maximum system pressure.



### **CAUTION**

#### **Danger of unexpected chemical reactions with water**

Residues of water in the pump that come from testing in the factory may react with the transferred medium.

- Before starting the pump for the first time, rinse it with a medium that is uncritical as regards water.

**⚠ CAUTION****Danger from hot surfaces**

The pump becomes hot during operation. Burns from hot surfaces or injuries from uncontrolled movements are possible.

- Do not touch the pump while it is operating.
- Ensure a sufficient supply of cool air and keep a safe distance between the pump and neighboring components.
- Operate the pump in accordance with the technical data.
- If the temperature of the medium is above 50°C, take safety precautions to prevent burns of fluid components.

Before switching on the pump, verify the following:

- All hoses are attached properly.
- Pump is mechanically fixed in place.
- Specifications of the power supply correspond with the data on the pump's type plate.
- Pump outlet is not blocked.
- All cables are attached properly.
- Contact protection for electrical connections and moving parts is installed.

**⚠ CAUTION****Danger of scalding from hot medium leaks**

In the terminal system, check the fluid system for leaks at the operating temperature of the medium.

**⚠ CAUTION****Danger from rotating parts**

The pump must not be operated with the housing cover open.

## 5 Maintenance

Ask your KNF representative about the availability of spare parts for this product.

Use only genuine parts from KNF for servicing work.

### 5.1 Cleaning



#### **⚠ WARNING**

##### **Danger due to dangerous substances in the pump**

Depending on the medium transferred, chemical burns or poisoning is possible.

- If necessary, wear protective equipment, such as safety gloves.
- Work on the pump or fluid circulation system only after they have been decontaminated and/or a decontamination declaration is present.
- Rinse the pump with a neutralizing liquid and then pump it empty.



#### **⚠ WARNING**

##### **Danger from medium spraying in the environment**

Due to pressure in the pump and adjacent parts, medium can spray out if hydraulic parts are manipulated or opened.

- Always depressurize the hydraulic parts of the system before carrying out any work.
- Disconnect the pump from the power supply and make sure that it cannot be switched on again inadvertently.

Clean the pump.

1. Clean and dry the parts with a cloth. Do not use solvents for cleaning, as they can harm plastic parts.
2. If compressed air is available, blow out the components.

## 5.2 Preparing for dismantling

1. Rinse the pump with a suitable neutralizing liquid and make sure that there are no dangerous substances left in the pump (see warnings above).
2. Pump the unit empty.
3. Disconnect electrical connections.
4. Remove hoses from pump head.

Tools

Qty	Tools
1	Torx screwdriver T30
1	Slotted screwdriver size 0
1	Allen key size 4mm

*Table 1*

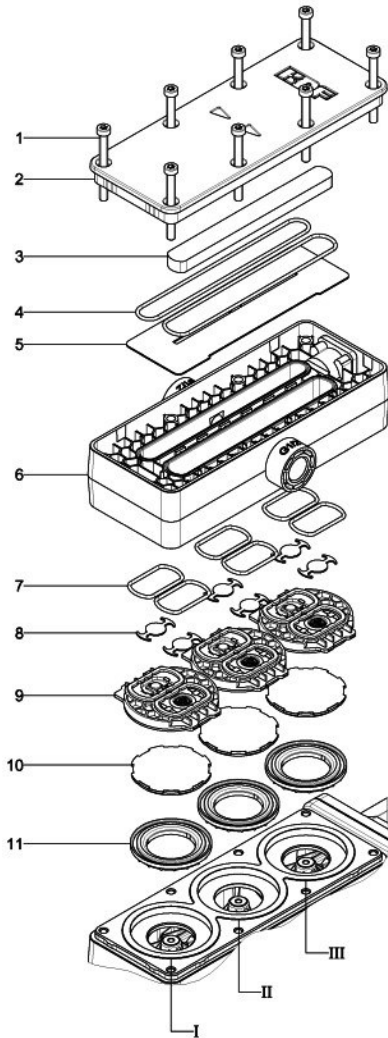

Figure 3: Head parts

- 1 Head screws
- 2 Head plate
- 3 Resonating diaphragm support (Cellasto)
- 4 O-ring resonating diaphragm
- 5 Resonating diaphragm
- 6 Connecton plate
- 7 O-rings valves
- 8 Anchor valves
- 9 Intermediate plate
- 10 Diaphragm
- 11 Insert ring

### 5.3 Dismantling the pump head

1. Undo the eight head screws (1) and remove the complete head from the pump housing.
2. Remove the head plate (2) from the connecting plate (6).
3. Remove the resonating diaphragm (5), both O-rings (4) and resonating diaphragm support (3) from the head plate (2).
4. Remove the three intermediate plates (9) according to Figure from the connecting plate (6) using a slot screwdriver (size 0).
5. Remove the six O-rings (7) and anchor valves (8) from the connecting plate (6). Note: Do not use sharp objects to remove the O-rings to avoid damaging them. Use compressed air to blow out the O-rings.
6. Undo the three diaphragms (10) by hand.
7. Remove the three insert rings (11) from the pump housing.
8. Clean all the parts, making sure that all residues are removed. Then blow them out with compressed air and dry them.

To ensure maximum tightness after opening the pump head, we recommend replacing the rubber parts, diaphragms (10), anchor valves (8), O-rings (7), oscillating diaphragm (5), and O-rings (4).

#### Cleaning the parts

9. Wipe the following items with a cloth and then blow them out with compressed air: O-Rings resonating diaphragm (4), resonating diaphragm (5), valve O-rings (7), anchor valves (8), and diaphragms (10).
10. Blow out the connecting plate (6) and intermediate plate (9) with compressed air.

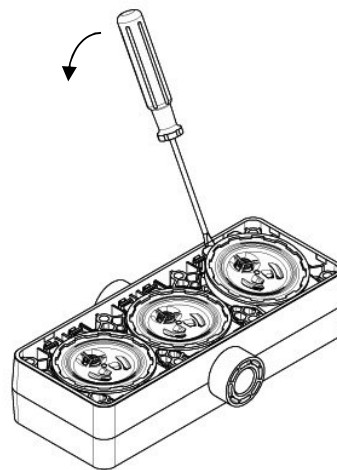

Figure 4: Dismantling the intermediate plate

## 5.4 Assembling the pump head

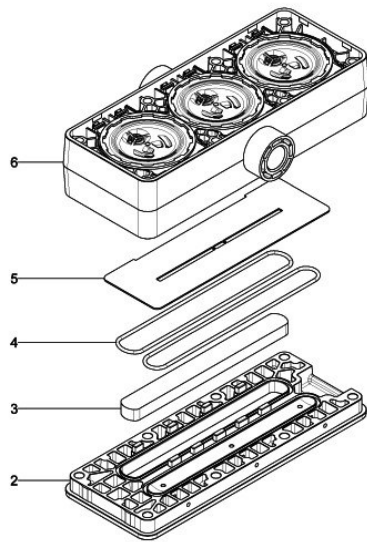

Figure 5: Head installation

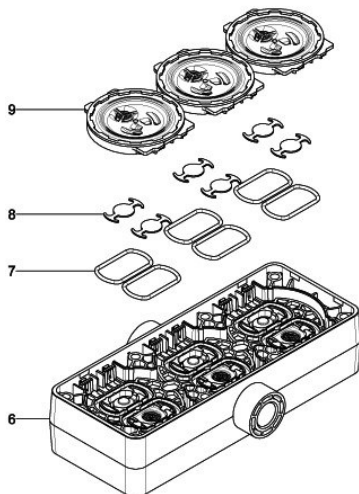

Figure 6: Installing the intermediate plate

1. Insert the three insert rings (11) in the pump housing; see Figure 3.
2. For easier installation of the diaphragms (10), turn the connecting rod to top dead center, beginning with head I. Tighten the diaphragms well (10) by hand. Repeat the steps for heads II and III.
3. For head II, press the middle diaphragm (10) to bottom dead center with your thumb.
4. Place the head plate (2) according to Figure .
5. Insert the resonating diaphragm support (3) and the two O-rings (4) into the head plate (2).
6. Place the resonating diaphragm (5) on the head plate (2) according to Figure . Make sure that the cut-out in the resonating diaphragm (5) and the cams in the head plate (2) are positioned correctly.
7. Insert the six O-rings (7) and anchor valves (8) in the connecting plate (6) according to Figure .
8. Click the three intermediate plates (9) into the connecting plate (6).
9. Place the connecting plate (6) on the head plate (2).
10. Place the complete head on the pump housing. Make sure that the head sits properly to ensure the desired transfer direction (direction of arrow).
11. Insert the eight head screws (1) in the head plate (2), but tighten them only slightly for now.
12. Tighten the four inside head screws (1) in a diagonal sequence by one rotation each.
13. Tighten the four outside head screws (1) in a diagonal sequence by one rotation each.
14. Repeat steps 12. and 13. until all the head screws (1) are tightened to 3.5 Nm. This procedure is important to ensure that the diaphragm is compressed equally, and the pump is leak-tight.

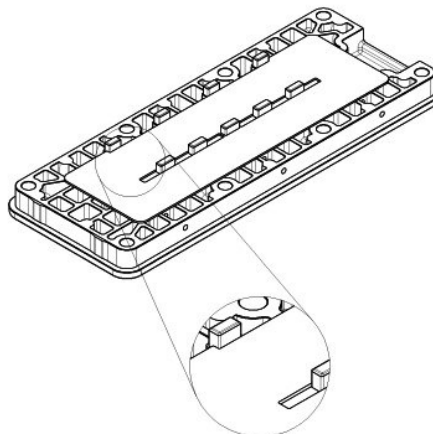

Figure 7: Installing the resonating diaphragm





**⚠ CAUTION**

**Caution, escaping liquid**

After assembly, the pump may not be leak-tight due to incorrect assembly, damaged or soiled seal faces, or other reasons.

- Run the pump for several minutes with a harmless medium at maximum operating pressure.
- Check that the pump is leak-tight.

## 6 Overpressure protection .27

Overpressure protection is provided as standard on this HazLoc model.

### 6.1 Dismantling and cleaning

To prepare for dismantling, refer to Section 5.2.

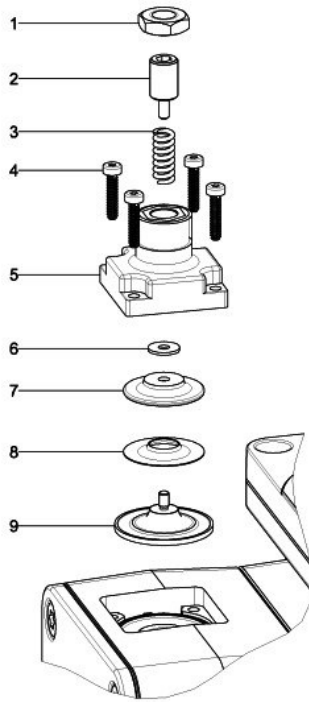

Figure 8: Overpressure protection

- 1 Hex nut
- 2 Set screw with bolt
- 3 Pressure spring
- 4 Head screws .27
- 5 Top part .27
- 6 Washer
- 7 Support
- 8 Sliding disk
- 9 Diaphragm .27

Tools

Qty	Tools
1	Allen key size 4mm
1	Torx screwdriver T10

Table 2

1. Unscrew the set screw (2) completely and remove it to relieve the pressure spring (3).

Note: Do not adjust the hex nut (1), as this defines the pressure and position for installation.

2. Undo the four head screws (4) and remove the top part (5).
3. Remove the pressure spring (3), washer (6), support (7), sliding disk (8), and diaphragm (9).

It is recommended that you replace the diaphragm (9).

#### Cleaning the overpressure protection

4. Clean and dry the parts with a cloth. Do not use solvents for cleaning, as they can harm plastic parts.
5. If compressed air is available, blow out the components.

### 6.2 Assembling

1. Insert the diaphragm (9) in the connecting plate.
2. Place the parts on the diaphragm (9) in the following order. Sliding disk (8), support (7), and washer (6).
3. Place the top part (5) on the connecting plate.
4. Tighten the four head screws (4) in a diagonal sequence to 0.7 Nm.
5. Insert the pressure spring (3) and turn the set screw (2) to its original position. Secure with the hex nut (1).

#### NOTICE

The pressure setting on the overpressure relief valve must be checked.



**⚠ CAUTION**

**Caution, escaping liquid**

After assembly, the overpressure protection may not be leak-tight due to incorrect assembly, damaged or soiled seal faces, or other reasons.

- Run the pump for several minutes with a harmless medium at maximum operating pressure.
- Check that the pump is leak-tight.

## 7 Rectifying transfer problems

Symptom	Cause	Remedy
Pump does not work; no movement or sounds are detectable.	No or incorrect control	Check that voltage and signal form comply with the specification.
Pump does not work; drive becomes very hot.	Motor is controlled with an incorrect signal.	Check that voltage and signal form comply with the specification.
The pump does not prime, or vacuum is insufficient.	External valve is closed.	Check external valve.
	Counterpressure on pressure side is too high.	Change the pressure conditions on the pressure side.
	Particles in the pump head	Rinse the pump head. Use a preventive preliminary filter.
Pump does not transfer.	External valve is closed, or filter is clogged or too small.	Check external valves and filter.
	Connections or hoses are blocked.	Check connections and hoses. Remove blockage.
Flow rate is insufficient or unstable.	Incorrect control	Check that voltage and signal form comply with the specification.
	Cross-section of hydraulic hoses or connectors too narrow or restricted	Disconnect the pump from the system and determine performance data. Remove restriction (e.g. valve), if necessary. If applicable, use larger-diameter hoses or connectors.
	Higher counterpressure in the system than assumed for the design	Contact KNF representative.
	Particles in the pump head	Rinse the pump head. Use a preventive preliminary filter. Replace pump head.
	Pump has reached the end of its service life.	Replace the pump.
Leak on pump head	Damage to the valve O-rings	Replace the O-rings.
	Diaphragm damaged	Replace the diaphragm.
	Resonating diaphragm damaged	Replace resonating diaphragm.

If the malfunction cannot be rectified, contact your local KNF representative ([www.knf.com](http://www.knf.com)).

## 8 Spare parts

### Spare parts kit, small

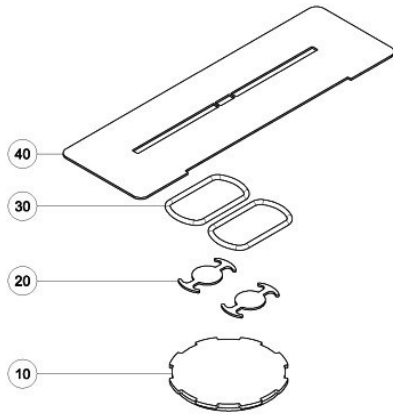

Figure 9: Spare parts kit, small

Pos	Name	Material <i>material</i>	Bestell-Nr. <i>order no.</i>	Stück im Kit <i>pieces in set</i>	Stück im Kit <i>pieces in set</i>
	Kit klein KP <i>kit small KP</i>		177998		
	Kit klein KT <i>kit small KT</i>		177999		
10	Wulstmembrane <i>diaphragm</i>	PTFE		-	1
		PTFE		1	-
20	Ankerventil <i>anchor valve</i>	EPDM		-	2
		FFKM		2	-
30	O-Ring ID34x2.5 <i>O-ring ID34x2.5</i>	EPDM		-	2
		FKM		2	-
40	Schwingmembrane <i>resonating diaphragm</i>	EPDM		-	1
		FKM		1	-

### Spare parts kit, large

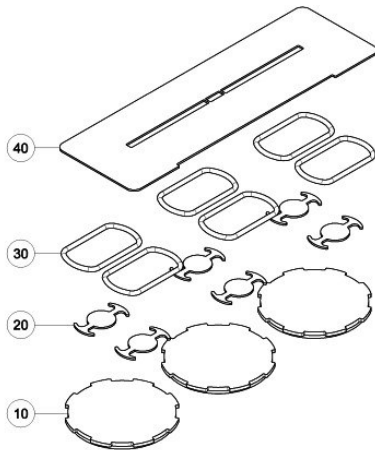

Figure 10: Spare parts kit, large

Pos	Name	Material <i>material</i>	Bestell-Nr. <i>order no.</i>	Stück im Kit <i>pieces in set</i>	Stück im Kit <i>pieces in set</i>
	Kit gross KP <i>kit large KP</i>		178000		
	Kit gross KT <i>kit large KT</i>		178001		
10	Wulstmembrane <i>diaphragm</i>	PTFE		-	3
		PTFE		3	-
20	Ankerventil <i>anchor valve</i>	EPDM		-	6
		FFKM		6	-
30	O-Ring ID34x2.5 <i>O-ring ID34x2.5</i>	EPDM		-	6
		FKM		6	-
40	Schwingmembrane <i>resonating diaphragm</i>	EPDM		-	1
		FKM		1	-

## 9 Returning the pump

KNF will accept the pump for repair only under the condition that the customer provides a certificate of the pumped medium and cleaning of the pump. For this purpose, please follow the instructions on [www.knf.com/repairs](http://www.knf.com/repairs).

Please contact your KNF sales representative directly if you need additional support for your return service.



# Installation, Operation and Maintenance Instructions

for AC Induction Motors  
56- 6800 Frames (NEMA)  
63 – 280 Frames (IEC)



*A REGAL-BELOIT COMPANY*

## **MARATHON ELECTRIC**

Contact Motor Customer Service at:

Phone: (715) 675-3311

[www.marathonelectric.com](http://www.marathonelectric.com)



**INSTALLER: PLEASE LEAVE THIS MANUAL FOR THE OWNER'S USE  
OWNER: READ AND SAVE THESE INSTRUCTIONS**

## **SAFETY INSTRUCTIONS**

**▲** This is the safety alert symbol. It is used to alert you to potential personal injury hazards. Obey all safety messages that follow this symbol to avoid possible injury or death.

### **▲ WARNING**

Before installing, using, or servicing this product, carefully read and fully understand the instructions including all warnings, cautions, & safety notice statements. To reduce risk of personal injury, death and/or property damage, follow all instructions for proper motor installation, operation and maintenance.

These instructions are not intended as a complete listing of all details for installation, operation, and maintenance. If you have any questions concerning any of the procedures, STOP, and call the appropriate Regal-Beloit motor company.

### **Table of Contents**

#### **1.0 INSTALLER / OWNER / OPERATOR RESPONSIBILITY**

- 1.1 **Electrical Safety**
- 1.2 **Mechanical Safety**
- 1.3 **Environmental Safety**

#### **2.0 RECEIVING & INSPECTION**

- 2.1 **Initial Inspection**
  - 2.1.1 **Packing List & Inspect**
  - 2.1.2 **Turn Motor Shaft**
  - 2.1.3 **Check Nameplate**

#### **2.2 Handling**

- 2.2.1 **Correct Lifting Angles**

#### **2.3 Storage**

- 2.3.1 **Bearing Lubrication**
- 2.3.2 **Shaft Rotation**
- 2.3.3 **Damp or Humid Storage Locations**

#### **3.0 INSTALLATION AND OPERATION**

##### **3.1 Location**

- 3.1.1 **Selecting a Location**
- 3.1.2 **Ambient Temperature Limits**
- 3.1.3 **Construction Selection per Location**
  - 3.1.3.1 **Dripproof**
  - 3.1.3.2 **Totally Enclosed**
  - 3.1.3.3 **Hazardous Locations Motors**

##### **3.2 Mounting Motor**

- 3.2.1 **Rigid Base (Footed)**
- 3.2.2 **Rigid Base Hole Selection -6 or 8 Hole Bases**
- 3.2.3 **Vertical**

##### **3.3 Application Assembly to Motor**

- 3.3.1 **General: Proper Alignment**

##### **3.3.2 Direct Coupling**

##### **3.3.3 Direct Connected**

##### **3.3.4 Belted**

##### **3.3.5 VFD Operation**

##### **3.3.6 Accessories**

###### **3.3.6.1 General**

###### **3.3.6.2 Brake Motors**

###### **3.3.6.3 Space Heaters**

###### **3.3.6.4 Thermal Protection General, Thermostats, Thermistors & RTDs**

###### **3.3.6.5 RTD Alarm & Trip Settings**

##### **3.3.7 Guards**

#### **3.4 Electrical Connections**

##### **3.4.1 Power Supply / Branch Circuit**

###### **3.4.1.1 Branch Circuit Supply**

###### **3.4.1.2 Fuses, Breakers, Overload Relays**

###### **3.4.1.3 AC Power Supply Limits**

##### **3.4.2 Terminal Box**

###### **3.4.2.1 Conduit opening**

###### **3.4.2.2 Hazardous Locations**

##### **3.4.3 Lead Connections**

###### **3.4.3.1 Wire Size Requirements (Single Phase)**

###### **3.4.3.2 Extension Cords (Single Phase)**

##### **3.4.4 Ground Connections**

##### **3.4.5 Start Up**

###### **3.4.5.1 Start Up – No Load Procedure**

###### **3.4.5.2 Start Up – Load Connected Procedure**

###### **3.4.5.3 Jogging and/or repeated starts**

#### **4.0 MAINTENANCE**

##### **4.1 General Inspection**

- 4.1.1 Ventilation
- 4.1.2 Insulation
- 4.1.3 Electrical Connections
- 4.2 Lubrication and Bearings
  - 4.2.1 Grease Type
  - 4.2.2 Bearing Operating Temperature

- 4.2.3 Lubrication Interval
- 4.2.4 Lubrication Procedure
- 4.2.5 Lubrication Example
- 4.3 Trouble Shooting
  - 4.3.1 General Trouble-Shooting Warnings
  - 4.3.2 Trouble-Shooting Cause / Corrective Action

motor is suitable for use on Pulse Width Modulated (PWM) type VFD power. In addition, the nameplate must be marked with the inverter rating; for example, "2:1 CT", "2 to 1 Constant Torque", etc.

## 1.0 INSTALLER/OWNER/OPERATOR RESPONSIBILITY:

### 1.1 ELECTRICAL SAFETY

#### **⚠ WARNING: ELECTRICAL SHOCK HAZARD**

Electrical connections shall be made by a qualified electrical personnel in accordance with all applicable codes, ordinances and sound practices. Failure to follow these instructions could result in serious personal injury, death and/or property damage. Only qualified personnel who are familiar with the applicable National Code (USA = NEC) and local codes should install or repair electrical motors and their accessories.

#### **⚠ WARNING: ELECTRICAL LIVE CIRCUIT HAZARD**

Do not touch electrically live parts. Disconnect, lockout and tag input power supply before installing or servicing motor (includes accessory devices). Use a voltmeter to verify that power is off before contacting conductors.

#### **⚠ WARNING: ELECTRICAL GROUNDING HAZARD**

Failure to properly ground motors, per the National Electrical Code (NEC) Article 430 and local codes may cause serious injury or death to personnel. For general information on grounding refer to NEC Article 250. (Also see "Ground Connections section 3.4.4").

#### **⚠ WARNING: AUTOMATIC RESET PROTECTOR HAZARD**

Do not use automatic reset protectors if automatically restarting the motor will place personnel or equipment at risk. Failure to follow this instruction could result in serious personal injury, death and/or property damage

#### **⚠ WARNING: MANUAL RESET PROTECTOR HAZARD**

If a tripped manual reset thermal protector is exposed to a temperature less than  $-7^{\circ}\text{C}$  ( $20^{\circ}\text{F}$ ) it may reset and restart the motor automatically. If an application requires a motor with a manual reset thermal protector that will be operated at temperatures less than  $-7^{\circ}\text{C}$  ( $20^{\circ}\text{F}$ ) contact the manufacturer to review the application / motor requirements. Failure to follow this instruction could result in serious personal injury, death and/or property damage

### 1.2 MECHANICAL SAFETY

#### **⚠ WARNING: LOOSE PARTS HAZARD**

Before starting the motor, remove all unused shaft keys and loose rotating parts to prevent them from flying off. Failure to follow these instructions could result in serious personal injury, death and/or property damage.

#### **⚠ WARNING: ROTATING PARTS HAZARD**

Keep extremities, hair, jewelry and clothing away from moving parts. Failure to follow these instructions could result in serious personal injury, death and/or property damage.

### 1.3 ENVIRONMENTAL SAFETY

#### **⚠ WARNING: HAZARDOUS LOCATIONS**

- (1) The NEC and the local authority having jurisdiction must be consulted concerning the installation and suitability of motors for use in Hazardous Locations. The local authority having jurisdiction must make the final determination of what type of motor is required. The application and operation is beyond the control of the motor manufacturer.
- (2) Division 1 Hazardous Locations motors can only be modified or reworked by the manufacturer or a facility that is Listed under UL's category "Motors and Generators, Rebuilt for use in Hazardous Locations". Failure to follow these instructions could result in serious personal injury, death and/or property damage.
- (3) Do not use a Hazardous Locations motor with a Variable Frequency Drive (VFD) unless the motor nameplate specifically states that the

## 2.0 RECEIVING AND INSPECTION

### 2.1 INITIAL INSPECTIONS

**2.1.1 CHECK PACKING LIST AND INSPECT** the packaging to make certain no damage has occurred in shipment. If there is visible damage to the packaging, unpack and inspect the motor immediately. Claims for any damage done in shipment must be made by the purchaser against the transportation company.

**2.1.2 TURN MOTOR SHAFT** by hand to be certain that it rotates freely. Note: Shaft seals and bearing seals may add drag.

**2.1.3 CHECK NAMEPLATE** for conformance with purchase order requirements and compliance with power supply and control equipment requirements.

### 2.2 HANDLING:

#### **⚠ WARNING: FALLING OBJECT HAZARD**

**Eyebolts or lifting lugs, where provided, are intended for lifting only the motor and accessories mounted by the motor manufacturer** (unless specifically stated otherwise on the motor). Utilizing the motor lifting provision to lift other components such as pumps and gear boxes could result in serious personal injury, death and/or property damage.

#### **⚠ WARNING: FALLING OBJECT HAZARD**

Before using the lifting provision, check the eyebolts and/or other lifting means to assure they are not bent or damaged and are completely threaded, seated & secured to the motor. Equipment to lift motor must have adequate lifting capacity. While lifting the motor DO NOT stand under or in the vicinity of the motor. Failure to follow these instructions could result in serious personal injury, death and/or property damage.

#### 2.2.1 LIFTING ANGLE LIMITATIONS

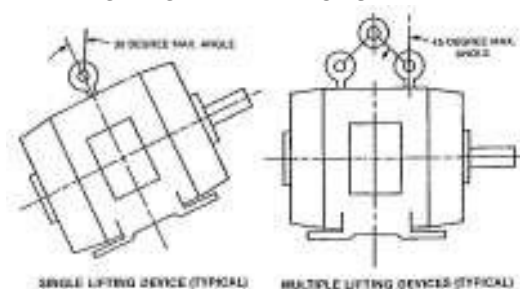

**2.3 STORAGE:** Motors, not put into service immediately, must be stored indoors in a clean, dry location. Avoid locations with large temperature swings that will result in condensation. Motors must be covered to eliminate airborne dust and dirt. If the storage location exhibits high vibration, place isolation pads under motor to minimize damage to motor bearings.

**2.3.1 BEARING LUBRICATION:** Bearings are grease packed at the factory; relubrication upon receipt of motor or while in storage is not necessary. If stored more than one year, add grease per lubrication instructions (Table 4-4) before start-up.

**2.3.2 SHAFT ROTATION:** It is recommended that the motor shaft be rotated 5 to 10 rotations every three months to distribute the grease in the bearings. This will reduce the chance for corrosion to form on the bearing rolling elements and raceways. Note: Shaft seals and bearing seals may add drag.

**2.3.3 DAMP OR HUMID STORAGE LOCATIONS:** Treat unpainted flanges, shafts, and fittings with a rust inhibitor. Apply appropriate power to the motor's space heaters (if so equipped)

**TEFC (Totally Enclosed Fan Cooled)** motors must meet a minimum distance of ½ the shaft height between the fan guard grill openings and the nearest obstruction.

**3.1.3.3 HAZARDOUS LOCATIONS MOTORS:** Hazardous Locations motors are intended for installations in accordance with NEC Article 500. For all installations involving Hazardous Locations motors, consult the applicable national codes, local codes, and the authority having jurisdiction.

**Division 1 Installations – includes Class I & II:** Use only motors that are UL Listed and CSA Certified or UL Listed and UL Certified for Canada. These motors bear a separate nameplate that includes the UL Listing Mark and CSA Certification Mark or includes the UL Listing Mark and the UL Mark for Canada. This plate also bears the phrase: "Electric motor for Hazardous Locations" and is marked with the Class, Group and Operating Temperature Code.

**Division 2 Installations – Class I only:** Use only motors that are CSA Certified and bear the CSA Certification Mark. These motors include a phrase on the main motor nameplate that indicates the motor is CSA Certified for Class I, Division 2 / Zone 2 locations.

**Division 2 Installation – Class II only:** Use only Class II motors as described above under "Division 1 Installations".

**WARNING: EXPLOSION HAZARD**

A motor should never be placed in an area with a hazardous process or where flammable gases or combustible materials may be present unless it is specifically designed and nameplated for this type of service. Hazardous Locations motors are intended for installations in accordance with NEC Article 500. For all installations involving Hazardous Locations motors, consult the NEC, local codes, and the authority having jurisdiction. Failure to follow these instructions could result in serious personal injury, death and/or property damage. (For other limitations see section 1.3)

### 3.0 INSTALLATION AND OPERATION

**WARNING:** Only qualified personnel who are familiar with the appropriate national code, local codes and sound practices should install or repair electrical motors and their accessories. Installation should conform to the appropriate national code as well as local codes and sound practices. Failure to follow these instructions could result in serious personal injury, death and/or property damage.

**WARNING: ELECTRICAL LIVE CIRCUIT HAZARD**

Do not touch electrically live parts. Disconnect, Lockout and Tag input power supply before installing or servicing motor (includes accessory devices). Use a voltmeter to verify that power is off before contacting conductors.

### 3.1 LOCATION

**3.1.1 SELECTING A LOCATION:** Consideration should be given to environment and ventilation. Motors should be installed in an area that is protected from direct sunlight, corrosives, harmful gases or liquids, dust, metallic particles, and vibration. A motor with the proper enclosure for the expected operating condition should be selected. Provide accessible clearance for cleaning, repair, service, and inspections (See section 3.1.3 for construction clearances). The location should be considered for possible future motor removal / handling. The free flow of air around the motor should not be obstructed.

**3.1.2 AMBIENT TEMPERATURE LIMITS:** The ambient temperatures of the air inlet to the motor should not exceed 40°C (104°F) or be less than -30°C (-22°F) unless the motor nameplate specifically states an ambient temperature outside of these limits. The ambient inside an enclosure built around the motor shall not exceed the nameplate ambient. For ambient temperatures outside of these limits consult the motor manufacturer.

**CAUTION: INSULATION DEGRADATION WARNING**  
Insulation at high temperatures ages at an accelerated rate. Each 10°C increase in temperature reduces the insulation life by one half.

**WARNING: HAZARDOUS LOCATIONS AMBIENT LIMIT:** Division 1 Hazardous Locations motors shall **NOT** be operated below -25°C (-13°F) ambient. (Low temperatures reduce the component mechanical properties.)

### 3.1.3 CONSTRUCTION SELECTION per LOCATION:

**3.1.3.1 DRIPPROOF (OPEN) MOTORS** are intended for use indoors where the atmosphere is relatively clean, dry, and non-corrosive. Recommended a minimum clearance of ½ the shaft height between vent openings and the nearest obstruction.

**3.1.3.2 TOTALLY ENCLOSED MOTORS** are suitable for indoor or outdoor standard service applications.

**TEAO or AOM (Totally Enclosed Air Over)** motors must be mounted in the air stream. When the motor nameplate states a minimum airflow the motor must be mounted in an air stream meeting this minimum value.

### 3.2 MOUNTING MOTOR:

**3.2.1 RIGID BASE (FOOTED):** The motor must be securely installed to a rigid foundation or a mounting surface to minimize vibration and maintain alignment between the motor shaft and the load's shaft. The mounting surfaces of the four mounting pads must be flat within 0.01 inches for 210 frame & smaller; 0.015 inches for 250 frame & larger. [IEC 0.25 mm for 130 frame & smaller, 0.38 mm for 160 frame & larger]. This may be accomplished by shims under the motor feet. For special isolation mounting, contact manufacturer for assistance

### 3.2.2 RIGID BASE HOLE SELECTION -6 OR 8 HOLES

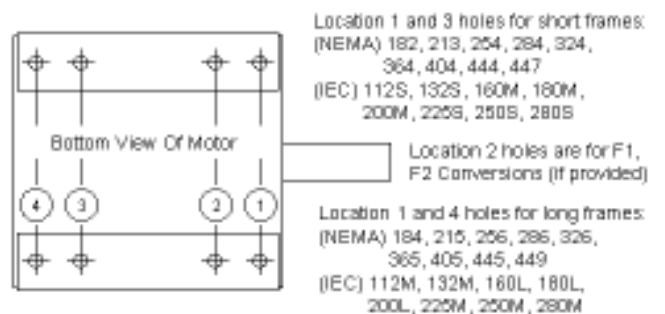

### 3.2.3 VERTICAL MOUNTING:

**CAUTION: ENCLOSURE PROTECTION CAUTION:** Most Drip-proof rigid base (footed) motors do **NOT** meet "Drip-proof" requirements when mounted vertically. If the motor is located in unprotected environments, the addition of a drip cover may be available. Drip covers not available for cast iron rigid base motors.

**WARNING: FALLING OBJECT HAZARD**

The lifting provision on standard horizontal footed motors is not designed for lifting the motor in a vertical shaft up or shaft down position. (see 2.2.1 lifting angles). Lifting method / provisions for

mounting a rigid base (footed) motor vertically is the responsibility of the installer.

**VERTICAL SHAFT DOWN:** Most standard horizontal motors thru 449 Fr. (excluding brake motors) can be mounted in a vertical shaft down orientation. For vertical brake motors see section 3.3.6.2.

**VERTICAL SHAFT UP:**

**WARNING: HAZARDOUS LOCATIONS VERTICAL MOUNT:** Hazardous locations motors must **NOT** be mounted vertically shaft up without approval by the motor manufacturer. Without proper retaining provisions the rotor may move axially and contact components, creating a spark hazard.

**Belted or Radial Load when mounted vertically:** The following frame sizes / constructions with applied (axial) down loads within the limit stated are acceptable when mounted vertical shaft up.

**Table 3-1 Belted or Radial Load Applications (All speeds)**

Frame Size	Enclosure	Construction	Shaft Up OK	Max Applied Down Load <sup>3</sup>
56	TEFC & ODP	Steel	Yes	25 lbs
140	TEFC	Steel & Cast Iron	Yes	25 lbs
	ODP	Steel	Yes	25 lbs
180	TEFC	All	Yes	35 lbs
	ODP	Steel	Yes	35 lbs
210	TEFC	All	Yes	40 lbs
	ODP	Steel	Yes	40 lbs
250	TEFC	All	Yes	40 lbs
	ODP	Steel	Yes	40 lbs
		Cast Iron	No <sup>2</sup>	N/A
280-320	320 TTFC models	Cast Iron	Eng <sup>1</sup>	N/A
	All Other TEFC	Cast Iron & Aluminum	Yes	30 lbs
	ODP	Cast Iron	No <sup>2</sup>	N/A
	TEFC & ODP	Steel	Build Up Only <sup>4</sup>	N/A
360 & Up	TEFC	Cast Iron	Build Up Only <sup>4</sup>	N/A
	ODP	Cast Iron	No <sup>2</sup>	N/A
	TEFC & ODP	Steel	Build Up Only <sup>4</sup>	N/A

Notes:

- For TEFC model numbers beginning with 324TTFC or 326TTFC consult the motor manufacturer to determine if a build up motor is required.
- The max applied down load is any applied load external to the motor, including such things as sheave weight, fan loads, axial belt force, pump load, etc. If the application is direct drive with no applied radial load, consult the motor manufacturer.
- "Build-up only", refers to motors that are specifically ordered and built for shaft up applications. It does not imply that all build-up motors are suitable for shaft up applications.

**3.3 APPLICATION ASSEMBLY TO MOTOR:**

**CAUTION: EQUIPMENT DAMAGE:**

Do not connect or couple motor to load until correct rotational direction is established.

**3.3.1 GENERAL: PROPER ALIGNMENT** of the motor and driven equipment minimizes vibration levels, maximizes bearing life, and extends the overall life of the machinery. Consult the drive or equipment manufacturer for more information.

**CAUTION: BEARING FAILURE**

During assembly do NOT force components onto the shaft. Striking or hammering the component may result in bearing damage.

**3.3.2 DIRECT COUPLING:** Use flexible couplings if possible. For applications that apply radial, axial or moment loading on the motor shaft see section 3.3.3.

**CAUTION: BEARING FAILURE**

Unless approved by the motor manufacturer do **NOT** direct couple a vertical shaft up or roller bearing motor. Direct coupling a vertical shaft up motor or a motor with a roller bearing may result in bearing damage.

**3.3.3 DIRECT CONNECTED:** Radial loading for direct connected equipment (gears, fans etc.) must be approved by the motor manufacturer unless within the maximum overhung load limits (Table 3-2). Combined loading (axial, radial and/or moments) must be approved by motor manufacturer. For belted loads see section 3.3.4.

**Table 3-2 Maximum Radial Load (lbf) @ Middle of the Shaft Extension Length**

Frame Number	Motor Rated RPM			
	3600	1800	1200	900
143T	106	166	193	210
145T	109	170	199	218
182T	187	230	261	287
184T	193	237	273	301
213T	319	317	470	510
215T	327	320	480	533
254T	500	631	729	793
256T	510	631	736	820
284T	-	866	990	1100
286T	-	871	1005	1107
324T	-	950	1100	1215
326T	-	950	1113	1230
364T	-	1078	1365	1515
365T	-	1078	1380	1540
404T	-	1388	1590	1762
405T	-	1400	1610	1780
444T	-	1580	1795	2005
445T	-	1520	1795	1985
447T	-	1455	1765	1985
449T	-	1640	1885	2130

Values based on 26,280 hrs B-10 Life  
 For "End of Shaft" Load multiply value by 0.88  
 To convert from lbf to N multiply value by 4.4482.

**3.3.4 BELTED:**

The goal of any belted system is to efficiently transmit the required torque while minimizing the loads on the bearings and shafts of the motor and driven equipment. This can be accomplished by following four basic guidelines:

- Use the largest practical sheave diameter.
- Use the fewest number of belts possible.
- Keep sheaves as close as possible to support bearings.
- Tension the belts to the lowest tension that will still transmit the required torque without slipping. It is normal for V-belts to squeal initially when line starting a motor

**3.3.4.1 Sheave Diameter Guidelines:**

In general, smaller sheaves produce greater shaft stress and shaft deflection due to increased belt tension. See Table 3-3 for recommended minimum sheave diameters. Using larger sheaves increases the contact with belts which reduces the number of belts required. It also increases the belt speed, resulting in higher system efficiencies. When selecting sheaves, do not exceed the manufacturer's recommended maximum belt speed, typically 6,500 feet per minute for cast iron sheaves. Determine belt speed by the following formula:

Figure 1

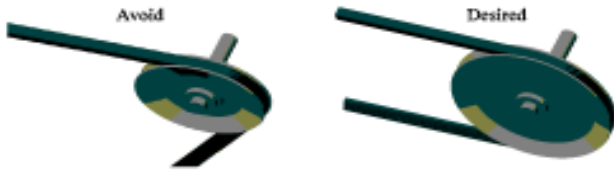

$$\text{BELT SPEED (Ft/min)} = \frac{\text{Shaft RPM} \times 3.14 \times \text{Sheave Dia (inches)}}{12}$$

### 3.3.4.2 Number of Belts

In general, use the fewest number of belts that will transmit the required torque without slipping. See Table 3-3 for recommended maximum number of belts. Each belt adds to the tension in the system, which increases load on the shafts and bearings. Belts are most efficient when operated at or near their rated horsepower. If the sheaves have more grooves than the number of belts required, use the grooves closest to the motor.

### 3.3.4.3 Sheave Location

Install sheaves as close to the housing as possible to increase the bearing life of the motor and driven equipment

### 3.3.4.4 Belt Tension

#### ⚠ CAUTION: Equipment Failure Caution

Belt tensioning by feel is **NOT** acceptable. Tensioning by "feel" can be very misleading, and can damage motor and equipment. It is normal for V-belts to squeal initially when line starting a motor.

In general, belt tensions should be kept as loose as possible while still transmitting the required torque without slipping. Belt tensions must be measured with a belt tension gage. These inexpensive gages may be obtained through belt manufacturers, or distributors.

Proper belt tension is determined by measuring the force required to deflect the center of the belt a given distance. The proper deflection (in inches) is determined by dividing the belt span in inches by 64. Calculate the proper deflection and then see Table 3-3 for the required "Deflected Force" to achieve that deflection.

After tensioning the belt, rotate the sheaves for several rotations or operate the system for a few minutes to seat belts into the grooves, then re-tension the belts. New belts will stretch during use, and should be retensioned after the first eight hours of use.

Figure 2

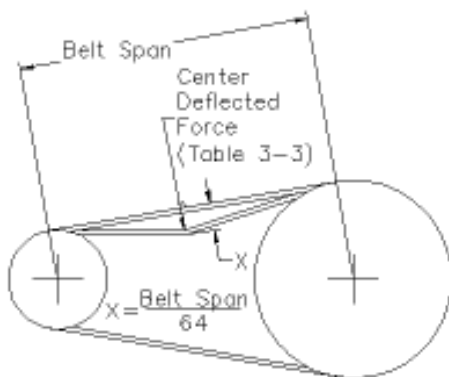
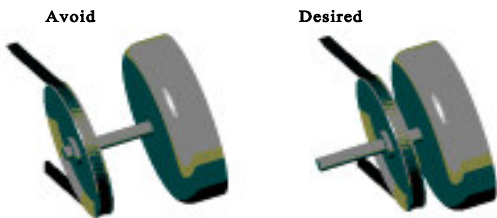

**Table 3-3 Recommended Minimum Sheave Diameters, Belt Type, Number of Belts and Deflected Force**

Motor Hp	1200 rpm				1800 rpm				3600 rpm			
	Min Sheave Dia (in)	Belt Type	Max # of Belts	Avg. Deflected Force (lbs)	Min Sheave Dia (in)	Belt Type	Max # of Belts	Avg. Deflected Force (lbs)	Min Sheave Dia (in)	Belt Type	Max # of Belts	Avg. Deflected Force (lbs)
0.75	2.2	3VX	1	2.4	2.2	3VX	1	2.2	2.2	3VX	1	1.2
1	2.4	3VX	1	4.0	2.2	3VX	1	3.1	2.2	3VX	1	1.6
1.5	2.4	3VX	2	3.1	2.4	3VX	2	2.1	2.2	3VX	1	2.5
2	2.4	3VX	3	2.8	2.4	3VX	2	2.9	2.4	3VX	1	2.7
3	3.0	3VX	2	3.3	2.4	3VX	3	2.9	2.4	3VX	2	2.3
5	3.0	3VX	3	4.0	3.0	3VX	3	3.7	2.4	3VX	3	2.5
7.5	3.8	3VX	4	4.7	3.0	3VX	4	4.1	3.0	3VX	2	4.2
10	4.4	3VX	4	5.4	3.8	3VX	4	4.3	3.0	3VX	3	3.8
15	4.4	3VX	5	5.4	4.4	3VX	4	5.4	3.8	3VX	3	4.4
20	5.2	3VX	6	6.0	4.4	3VX	6	4.8	4.4	3VX	3	5.0
25	6.0	3VX	7	5.6	4.4	3VX	7	5.2	4.4	3VX	4	4.7
30	6.8	3VX	7	5.9	5.2	3VX	7	5.3				
40	6.8	5VX	4	11.6	6.0	3VX	7	6.0				
50	8.2	5VX	4	14.6	6.8	3VX	8	5.9				
60	8.2	5VX	5	14.1	7.4	5VX	4	13.3				
75	10.0	5VX	5	14.5	8.6	5VX	4	14.3				
100	10.0	5VX	6	16.0	8.6	5VX	6	13				
125	12.0	5V	7	14.1	10.5	5V	6	13.1				
150	13.2	5V	7	15.4	10.5	5V	7	13.4				
200	15.0	5V	8	16.0	13.2	5V	8	13.1				
250	15.0	8V	6	27.6	14.0	5V	9	13.8				
300	16.0	8V	7	27.1	14.0	5V/8V	11 / 7	23.4				
350	16.5	8V	7	30.3	14.5	5V/8V	12 / 7	26.0				
400	17.5	8V	8	29.1	15.0	5V/8V	13 / 8	25.7				
450	18	8V	8	31.6	16.0	5V/8V	14 / 9	25.2				
500	18.5	8V	9	30.7	16.5	5V/8V	15 / 9	26.9				
600					17.5	8V	11	26.3				
700					19.0	8V	12	27.3				
800					20.0	8V	13	28.2				

**Contact Motor Manufacturer when Belting 3600 rpm Motors Greater than 25 HP**

**Notes:**

1. Horsepower is the nameplate motor horsepower, and RPM is the motor (driver) speed.
2. Minimum sheave diameters are from NEMA standards where applicable.
3. **For variable speed applications or values outside these recommendations, consult motor manufacturer.**
4. Selections are based on a 1.4 service factor, 5 to 1 speed ratio and various Power Transmission Manufacturers' catalogs.
5. These selections are for Narrow V-belt sections only. Consult manufacturer for details on conventional V-belt sections (A, B, C, D and E), or other belt types.
6. "Average Deflected Force is per section 3.3.4.4 of this document and is the force required to deflect the center of a belt 1/64 of the belt span distance. Tolerance on this force is ±1 lbf for forces ≤10 lbs, and ±2 lbs for forces >10 lbs as measured utilizing a belt tension gage.
7. When more than one belt is required the belts must be a matched set (matched for length).
8. If possible, the lower side of the belt should be the driving side to increase the length of wrap on the sheave).
9. For belted loads do not exceed 125% of 60 Hz operating RPM.

**3.3.5 VFD (Variable Frequency Drives) OPERATION:**

**⚠ WARNING: VFD Motors with Reset Thermal Protectors**  
UL Recognition, UL Listing, or CSA certification does not apply to motors that are equipped with a manual or automatic reset thermal protector when the motor is operated on VFD power.

**⚠ WARNING: Power Factor Correction Capacitors:**  
Power factor correction capacitors should never be installed between the drive and the motor.

**⚠ CAUTION: VFD / Motor Setup:**  
It is the responsibility of the startup personnel during set up of the VFD / motor system to properly tune the drive to the motor for the specific application per the VFD user manual. The correct voltage boost and volts per hertz settings are application dependent and unique to each motor design. Failure to connect over temperature devices (when provided) will void the warranty.

**3.3.5.1 Overspeed Capability:**

Belted loads: Do not exceed 125% of 60 Hz operating RPM.

**Table 3-4 Maximum Safe Continuous Speed (RPM) For Coupled and Direct Connected Loads**

NEMA / [IEC] Frame Size	2-Pole	4, 6, or 8 Pole
56-180 [80-110]	7200 *	5400 *
210-250 [130-160]	5400 *	4200*
280 [180]	5400 *	3600
320 [200]	4500 *	3600
360 [225]	4500 *	2700
400-440 [250-280]	3600	2700
>440 [>280]	3600	1800

\* = Fan cooled motors (Totally Enclosed & Hazardous Locations Motors) are limited to a maximum safe continuous speed of 4000 RPM **For higher speeds or shortened duty cycle contact motor manufacturer**

**3.3.5.2 Cable Lengths:** For optimum insulation life, limit VFD to motor cable lengths of general purpose motors

to Table 3-5 values. Definite purpose VFD motors may accommodate longer cable lengths. For additional information contact motor manufacturer.

**Table 3-5 Max Cable Lengths General Purpose Motors**

These values are based on 3 kHz carrier frequency. Add suitable VFD output-side filters when exceeding the listed values.

Frame Size	230V	460 V	575 V
NEMA 56-320	600 ft.	125 ft.	40 ft.
NEMA 360-5011	1000 ft.	225 ft.	60 ft.
IEC 80-200	180 m.	40 m.	12 m.
IEC 225-280.	300 m.	70 m.	18 m.

**3.3.5.3 VFD Grounding:** Equipment grounding conductors may be run in the same conduit as the AC motor power leads. This wire must be used as the equipment ground for the motor and not as the fourth current carrying wire of a “WYE” motor circuit. The grounded metal conduit carrying the output power conductors can provide EMI shielding, but the conduit does not provide an adequate ground for the motor; a separate grounding conductor must be used. Grounding the motor neutral (WYE) of a VFD powered motor may result in a VFD ground fault trip. Improper grounding of an inverter fed motor may result in frame voltages in excess of 500 Volts. Refer to Grounding section 3.4.4

**3.3.5.4 VFD – Single Phase:**

**CAUTION: SINGLE PHASE MOTOR FAILURE:**

Single Phase motors are **NOT** suitable for use on VFD power. Connecting a Single Phase Motor to a VFD voids the warranty.

**3.3.5.5 Stray Voltage on Accessory Leads:**

VFD’s will couple stray (common-mode) voltage to motor-mounted RTDs, thermistors, thermostats and space heaters. The leads of these elements must be properly insulated and control input circuits must be designed to withstand this common-mode voltage.

**3.3.6 ACCESSORIES / PROVISIONS:**

**3.3.6.1 General:** Carefully read and understand the accessory manufacturer’s instructions, supplied with motor. Contact the manufacturer for additional information.

**3.3.6.2 Brake Motors:**

**CAUTION: Vertical Motor Premature Brake Failure**

Motors with brakes that are designed for vertical applications are equipped with springs to support the brake pressure plate. Mounting a horizontal brake motor vertically shaft up or down may require a pressure plate spring modification. Failure to modify the brake for the vertical application may result in premature brake failure. If in question, consult brake literature or brake manufacturer.

**Brake Solenoid Wiring:** Do NOT connect the brake solenoid to the output of a VFD. The brake solenoids must be wired to 50/60 Hz line power

**3.3.6.3 Space Heaters:**

Motors provided with space heaters have two leads that are brought into the conduit box or into an auxiliary box. These leads are marked “H1”, “H2” (“H3”, “H4” if a second space heater is supplied). See the space heater nameplate on motor for heater rating.

**WARNING: DIVISION 2 EXPLOSION HAZARD**

The space heater temperature rating when used in Class I, Division 2 motors shall **NOT** exceed 80% of the auto ignition temperature of the hazardous gas or vapor. See the space heater nameplate on motor for heater Temperature Code and heater rating. Failure to follow this instruction could result in serious personal injury, death and/or property damage

**3.3.6.4 Thermal Protection:**

**General Information:** When thermal protection is provided, one of the following will be stamped on the nameplate:

1. **“THERMALLY PROTECTED”** This motor has built in thermal protection. Thermal protectors open the motor circuit electrically when the motor overheats or is overloaded. The protector cannot be reset until the motor cools. If the protector is automatic, it will reset itself. If the protector is manual, disconnect motor from power supply. After protector cools (five minutes or more) press the reset button and reapply power to the motor. In some cases a motor is marked “Auto” and the connection diagram on the motor will identify T’Stat leads – see “2” below. (See warnings on Manual and Automatic reset protectors - section 1.1)

2. **“WITH OVERHEAT PROTECTIVE DEVICE”:** This motor is provided with an overheat protective device that does not directly open the motor circuit. Motors nameplated with this phrase have either thermostats, thermistors or RTD’s. The leads to these devices are routed into the motor conduit box or into an auxiliary box. The lead markings are defined on the nameplate (normally “P1”, “P2”) . The circuit controlled by the overheat protection device must be limited to a maximum of 600 volts and 360 volt-amperes. See connection decal provided inside the terminal box cover. Failure to connect these over temperature devices (when provided) will void the warranty.

**WARNING: EXPLOSION HAZARD**

For Hazardous Locations motors provided with thermostats UL and the NEC require connection of thermostat leads into the control portion of a manual reset start circuit. Failure to follow this instruction could result in serious personal injury, death and/or property damage

**Resistance Temperature Detectors (RTD):** When winding and/or bearing RTDs are provided the RTD lead markings are defined on the nameplate. (Normally “R1”, “R2”, “R3” etc.)

**3.3.6.5 RTD Alarm & Trip Settings:**

Tables 3-6 & 3-7 are suggested initial RTD alarm and trip settings. For motors found to operate significantly below these values the settings may be reduced accordingly.

**Table 3-6 Winding RTD – Temperature Limit (°C)  
40 °C Max Ambient**

Motor Load	Class B Temp Rise ≤ 80°C		Class F Temp Rise ≤ 105°C	
	Alarm	Trip	Alarm	Trip
Up to 1.0 SF	130	140	155	165
>1.0 to 1.15 SF	140	150	160	165

**Table 3-7 Bearing RTD – Temperature Limit (°C)  
40 °C Max Ambient**

Ambient	Alarm	Trip
Up to 40°C	95	100
> 40°C	110	115
Bearings that are Heat Stabilized to 150 °C	130	135

**3.3.7 GUARDS:**

**WARNING: ROTATING PARTS HAZARD**

When devices are assembled to the motor shaft, be sure to install protective devices such as belt guards, chain guards, and shaft covers. These devices must protect against accidental contact with extremities, hair, and clothing. Consider the application and provide guarding to protect personnel. Remove all unused shaft keys and loose rotating parts to prevent them from flying off and causing bodily injury. Failure to follow this warning could result in serious personal injury, death and/or property damage.

### 3.4 ELECTRICAL CONNECTIONS:

#### **WARNING: ELECTRICAL HAZARDS**

Before proceeding read Section 1-1 on Electrical Safety. Failure to follow the instructions in Section 1-1 could result in serious personal injury, death and/or property damage

#### 3.4.1 POWER SUPPLY / BRANCH CIRCUIT

##### **WARNING: POWER SUPPLY INCOMPATIBILITY HAZARD**

Check power supply to make certain that voltage, frequency and current carrying capacity are in accordance with the motor nameplate. Failure to match motor nameplate values could result in serious personal injury, death and/or property damage

##### **WARNING: BRANCH CIRCUIT SUPPLY HAZARD**

Motor and control wiring, fusing, overload protection, disconnects, accessories and grounding must always conform to the applicable electrical codes as well as local codes and sound practices.

**3.4.1.1 Branch Circuit Supply** to a motor should include a disconnect switch, short circuit current fuse or breaker protection, motor starter (controller) and correctly sized thermal elements or overload relay protection.

#### 3.4.1.2 Fuses, Breakers, Overload Relays

Short Circuit Current Fuses or Breakers are for the protection of the branch circuit. Starter or motor controller overload relays are for the protection of the motor. Each of these should be properly sized and installed per the applicable electrical codes as well as local codes and practices.

##### **WARNING: PROTECTIVE DEVICE DISABLED HAZARD**

DO NOT bypass or disable protective devices. Protection removal could result in serious personal injury, death and/or property damage

#### 3.4.1.3 AC Power Supply Limits

Motors are designed to operate within the following limits at the motor terminals:

- 1- AC power is within +/- 10 % of rated voltage with rated frequency applied. (Verify with nameplate ratings) **OR**
- 2- AC power is within +/- 5% of rated frequency with rated voltage **OR**
- 3- A combined variation in voltage and frequency of +/- 10% (sum of absolute values) of rated values, provided the frequency variation does not exceed +/-5% of rated frequency.
- 4- For 3 phase motors the line to line full load voltage must be balanced within 1%.
- 5- If the motor is rated 208-230V, the voltage deviations must be calculated from 230V.

#### **CAUTION: Reduced Motor Performance**

Operation outside of these limits will degrade motor performance and increase operating temperature.

### 3.4.2 TERMINAL BOX:

**3.4.2.1 Conduit Opening:** For ease of connections, motors are typically provided with large terminal boxes. Most motors have conduit access in 90 degree increments, the terminal box conduit opening is typically provided via knockouts, holes with covers, or the terminal box is rotate-able. Fabricated conduit boxes may have a removable plate for the installer to provide correctly sized hole(s).

#### 3.4.2.2 Hazardous Locations Motors:

##### **WARNING: EXPLOSION HAZARDS**

**(1) Terminal Boxes mounted to motor with a pipe nipple:** If a pipe nipple mounted terminal box is removed or rotated it must be reassembled with a minimum of five full threads of engagement.

**(2) Component Removal:** Do not set a terminal box component on its machined surfaces. Prior to component reassembly wipe clean all machined surfaces.

**(3) Machined Surface Gap (Hazardous Locations Terminal Boxes):** The gap between mating surfaces with the machined terminal box MUST BE LESS THAN 0.002 inches. This gap must be checked with a feeler gage along the entire perimeter. If there is visible damage to the mating surfaces, or if the gap between these surfaces exceeds 0.002 inches, DO NOT complete the installation and contact the motor manufacturer. Failure to follow these instructions could result in serious personal injury, death and/or property damage

### 3.4.3 LEAD CONNECTIONS

Electrical connections to be made per nameplate connection diagram or separate connection plate. In making connections follow the applicable electrical code as well as local codes and practices.

##### **WARNING: ELECTRICAL CONNECTION HAZARD**

Failure to correctly connect the motor leads and grounding conductor can result in injury or death. Motor lead connections can short and cause damage or injury if not well secured and insulated.

#### 3.4.3.1 Wire Size (Single Phase) Requirements

The minimum wire size for Single Phase, 115 & 230 Volt Circuits must meet table 3-8 for a given distance between motor and either Fuse or Meter Box.

**Table 3-8 Minimum Wire Gage Size Single Phase 115 & 230 Volt Circuits**

Distance (Feet) - Motor to Fuse or Meter Box								
Motor	100 Ft.		200 Ft.		300 Ft.		500 Ft.	
HP	115	230	115	230	115	230	115	230
1/4	14	14	10	12	8	10	6	8
1/3	12	14	10	12	6	10	4	8
1/2	10	12	8	10	6	8	4	6
3/4	10	12	6	10	4	8	2	6
1	8	10	6	8	4	6		4
1 1/2	4	10	0	8		6		4
2		8		6		4		2
3		8		6		4		2
5		6		4		2		0

#### 3.4.3.2 Extension Cords (Single Phase Motors):

Where an extension cord(s) is utilized to provide power to the motor the extension cord(s) must be...(1) the proper gauge size per table 3-8, (2) in good working condition (3) properly grounded.

### 3.4.4 GROUND CONNECTION(S):

##### **WARNING: ELECTRICAL GROUNDING HAZARD**

For general information on grounding (USA) refer to NEC Article 250. Improper grounding of an inverter fed motor may result in frame voltages in excess of 500 Volts. In making the ground connection, the installer must make certain that a good electrical connection is obtained between motor and grounding lead. Failure to properly ground motors, per the applicable national code (such as NEC Article 430) and local codes may cause serious injury or death to personnel.

**Primary "Internal" Ground:** A grounding conductor must be connected to the grounding terminal provided in the terminal housing. This grounding terminal is either a ground screw, ground lug, or a tapped hole to be used with a separately provided ground screw. The internal grounding feature is accessible inside the terminal housing and must be used as the primary grounding connection.

**Secondary "External" Ground:** Some motors are provided with a supplemental grounding terminal located on the external surface of the motor frame or feet. This external terminal is for supplemental bonding connections where local codes permit or require such connection

### 3.4.5 START UP:

##### **WARNING: ELECTRICAL SHOCK HAZARD:**

Be certain that all connections are secure and the conduit box cover is fastened in place before electrical power is connected. Failure to follow these instructions could result in serious personal injury, death, and/or property damage.



Do not start more than twice in succession under full load. Repeated starts and/or jogs of induction motors can cause overheating and immediate failure. Contact the motor manufacturer if it is necessary to repeatedly start or jog the motor.

### **WARNING: LOOSE & ROTATING PARTS HAZARD**

Before proceeding read Section 1-2 on Mechanical Safety. Failure to follow the instructions in Section 1-2 could result in serious personal injury, death and/or property damage

### **WARNING: EXCESSIVE SURFACE TEMPERATURE HAZARD**

Motors with the temperature code stated on the nameplate are designed to operate within this limit. Improper application or operation can cause the maximum surface temperature to be exceeded. A motor operated in a Hazardous Location that exceeds this surface temperature limit increases the potential of igniting hazardous materials. *Therefore, motor selection, installation, operation, and maintenance must be carefully considered to ensure against the following conditions:* (1) Motor load exceeds service factor value, (2) Ambient temperature above nameplate value, (3) Voltages outside of limits (3.4.1.3), (4) Loss of proper ventilation, (5) VFD operation exceeding motor nameplate rating, (6) Altitude above 3300 feet / 1000 meters, (7) Severe duty cycles, (8) Repeated starts, (9) Motor stall, (10) Motor reversing, and (10) Single phase operation. Failure to follow these instructions could result in serious personal injury, death and/or property damage.

### **CAUTION: HOT SURFACE**

Normal motor surface temperatures may exceed 90 ° C (194° F). Touching the motor frame may cause discomfort or injury. Surface temperatures should only be measured with suitable instruments and not estimated by hand touch.

#### **3.4.5.1 Start Up - No Load Procedure**

- 1. Check Instructions:** Before startup carefully read and fully understand these instructions including all warnings, cautions, and safety notice statements.
- 2. Motor out of storage after more than three months:**  
Check winding insulation integrity with a Megger. If winding resistance to ground is less than 1.5 Meg-ohms consult the local authorized service shop before energizing the motor.
- 3. Check Installation: Mechanical** - Check tightness of all bolts and nuts. Manually rotate the motor shaft to ensure motor shaft rotates freely. Note: Shaft & bearing seals will add drag.  
**Electrical** - Inspect all electrical connections for proper terminations, clearance, mechanical tightness and electrical continuity. Be sure to verify connections are made per the nameplate connection diagram or separate connection plate. Replace all panels and covers that were removed during installation before energizing the motor.
- 4. Energize Motor: Check Rotation**  
If practical check motor rotation before coupling to the load. Unlock the electrical system. Momentarily provide power to motor to verify direction of rotation. If opposite rotation is required, lock out power before reconnecting motor. If motor has a rotational arrow only operate the motor in the rotation identified. Reapply power to ensure proper operation.
- 5. Record No Load Amps, Watts & Voltage:**  
Recommend - To establish a baseline value check and record the no load amps, watts, and voltage.

#### **3.4.5.2 Start Up – Load Connected Procedure**

- 1. Check Instructions:** Before startup carefully read and fully understand these instructions including all warnings, cautions, & safety notice statements.
- 2. Coupling Installation:** Check that the connected equipment is properly aligned and not binding. Check that all guards and protective devices are properly installed.
- 3. Energize Motor:** When all personnel are clear of the machine, apply power and verify that the load is not transmitting excessive vibration back to the motor through the shaft or the foundation. Verify that motor amps are within nameplate rating. For repeated starts see 3.4.5.3. The equipment can now be fully loaded and operated within specified limits as stated on the nameplate.

#### **3.4.5.3 Jogging and/or Repeated Starts**

## **4.0 MAINTENANCE:**

 **WARNING: Hazardous Locations Motor Repair HAZARD:**  
Division 1 Hazardous Locations motors can only be modified or repaired by the manufacturer or a facility that is Listed under UL's category "Motors and Generators, Rebuilt for use in Hazardous Locations". Failure to follow these instructions could result in serious personal injury, death and/or property damage.

 **WARNING: ELECTRICAL SHOCK HAZARD**  
Electrical connections are to be made by qualified electrical personnel in accordance with all applicable codes, ordinances and sound practices. Failure to follow these instructions could result in serious personal injury, death and/or property damage. Only qualified personnel who are familiar with the applicable national codes, local codes and sound practices should install or repair electric motors and their accessories.

 **WARNING: ELECTRICAL LIVE CIRCUIT HAZARD**  
Do not touch electrically live parts. Disconnect, lockout and tag input power supply before installing or servicing motor (includes accessory devices).

### **4.1 GENERAL INSPECTION**

Inspect the motor approximately every 500 hours of operation or every three months, whichever occurs first. Keep the motor clean and the ventilation and fin openings clear. The following steps should be performed at each inspection:

**4.1.1 VENTILATION:** Check that the ventilation openings and/or exterior of the motor is free of dirt, oil, grease, water, etc, which can accumulate and block motor ventilation. If the motor is not properly ventilated, overheating can occur and cause early motor failure.

**4.1.2 INSULATION:** Use a "Megger" periodically to ensure that the integrity of the winding insulation has been maintained. Record the Megger readings. If winding resistance to ground is less than 1.5 Meg-ohms consult the local authorized service shop before re-energizing the motor.

**4.1.3 ELECTRICAL CONNECTIONS:** Check all electrical connectors to be sure that they are tight.

### **4.2 LUBRICATION & BEARINGS:**

The lubricating ability of grease (over time) depends primarily on the type of grease, the size of the bearing, the speed at which the bearing operates and the severity of the operating conditions. Longer bearing life can be obtained if the listed recommendations are followed:

NOTE: If lubrication instructions are provided on the motor nameplate, the nameplate instructions will supersede these instructions. Motors marked "Permanently Lubricated" do not require additional service.

### **CAUTION: BEARING / MOTOR DAMAGE WARNING**

Lubricant should be added at a steady moderate pressure. If added under heavy pressure bearing shield(s) may collapse. Over greasing bearings greatly increases bearing friction and can cause premature bearing and/or motor failure.

**4.2.1 GREASE TYPE (unless nameplate states otherwise):**  
**Nameplate Ambient Temperature between -30°C (-22°F) to 65°C (150°F) inclusive:** Recommended grease for standard service conditions is Mobil Polyrex® EM. Equivalent and compatible greases include: Texaco Polystar RB, Rykon Premium #2, Pennzoil Pen 2 Lube, Chevron SRI & Mobil SHC 100.

**Nameplate Ambient Temperature below -30°C (-22°F):** Special low temperature grease is recommended, such as Aershell 7 or Beacon 325 for ball bearings and Mobil SHC 100 for roller bearings.

**Nameplate Ambient Temperature above 65°C (150°F):** Dow Corning DC44 or equivalent, a special high temperature grease is required. Note that Dow Corning DC44 grease does not mix with other grease types.

For RTD settings see Table 3-7.

**4.2.2 BEARING OPERATING TEMPERATURE:**

**⚠ CAUTION: HOT SURFACE**

The external surface temperature of the end shield (bracket) bearing hub may reach 100° C (212° F) during normal operation. Touching this surface may cause discomfort or injury. Surface temperatures should only be measured with suitable instruments and not estimated by hand touch.

**4.2.3 LUBRICATION INTERVALS: (For motors with regreasing provisions)**

**Eq. 4.2**  $\text{Lubrication Interval} = [(\text{Table 4-1 hrs}) \times (\text{Interval Multiplier (Table 4-2)}) \times (\text{Construction Multiplier (Table 4-3)})]$

**Table 4-1 Lubrication Intervals (Hours)** These values are based on average use.

NEMA / [IEC] Frame Size	Operating Speed – RPM (See Table 3.4 for Maximum Operating Speed)					
	<7200	<5400	<4500	<3600	<1800	<1200
56-180 [80-110]	2500 Hrs.	4000 Hrs	5000 Hrs	6000 Hrs.	17000 Hrs.	20000 Hrs.
210-250 [130-160]		2500 Hrs	4000 Hrs	5000 Hrs.	12000 Hrs.	16000 Hrs.
280 [180]		2000 Hrs	3000 Hrs	4000 Hrs.	10000 Hrs.	14000 Hrs.
320 [200]			2000 Hrs	3000 Hrs.	9000 Hrs.	12000 Hrs.
360 [225]			1500 Hrs	2000 Hrs.	8000 Hrs.	10000 Hrs.
400-440 [250 – 280]				1500 Hrs.	4000 Hrs.	7000 Hrs.
>440 [>280]				1000 Hrs.	3000 Hrs.	5000 Hrs.

**Seasonal Service:** If motor remains idle for more than six months, Lubricate at the beginning of the season, then follow lubrication interval.  
**Do not exceed maximum safe operating speed Table 3-4 without manufacturer’s approval**

**Table 4-2 Service Conditions**

**Use highest level Multiplier:** Maximum Ambient Temperature and Contamination are independent factors

Severity of Service	Maximum Ambient Temperature	Atmospheric Contamination	Multiplier
Standard	Less than 40° C (104° F)	Clean, Slight Corrosion, indoors, less than 16 hrs per day	1.0
Severe	Above 40° C (104° F) to 50° C	Moderate dirt or Corrosion or outdoors or more than 16 hrs per day	0.5
Extreme	Greater than 50° C or Class H Insulation	Severe dirt or Abrasive dust or Corrosion	0.2

**Table 4-3 Construction Multiplier**

Construction	Multiplier
Angular Contact or Roller Bearing	0.5
Vertical Motor	0.5
All others	1.0

**Table 4-4 Relubrication Amounts**

Frame Size		Volume		
NEMA	IEC	Cu. In.	Fluid oz	ml
48-56	80	0.25	0.14	4.0
143-145	90	0.25	0.14	4.0
182-184	110	0.50	0.28	8.0
213-215	130	0.75	0.42	12.5
254-256	160	1.00	0.55	16.0
284-286	180	1.50	0.83	25.0
324-326	200	2.00	1.11	33.0
364-365	225	3.00	1.66	50.0
404-405	250	3.80	2.11	62.0
444-449	280	4.10	2.27	67.0
>449	>280	4.50	2.50	74.0

For regreasing while operating multiply volume by 125%.

#### 4.2.4 LUBRICATION PROCEDURE: (For Motors with Regreasing Provisions)

##### **CAUTION: BEARING DAMAGE WARNING**

Added grease must be compatible with the original equipment's grease. If a grease other than those stated in 4.2.1 is to be utilized contact the motor manufacturer. Nameplate information supersedes section 4.2.1 (GREASE TYPE). New grease must be free of dirt. Failure to follow these instructions and procedure below may result in bearing and/or motor damage.

For an extremely dirty environment, contact the motor manufacturer for additional information.

##### **LUBRICATION PROCEDURE:**

1. Clean the grease inlet plug or zerk fittings prior to regreasing.
2. (If present) Remove grease drain plug and clear outlet hole blockage.

##### **CAUTION: GREASE DRAIN PLUGGED:**

Old grease may completely block the drain opening and must be mechanically removed prior to regreasing. Forcing a blocked drain open by increased greasing pressure may collapse bearing shields and / or force excess grease through the bearings and into the motor.

3. Add grease per Table 4-4
4. Re-install grease inlet and drain plugs (if removed).

##### **WARNING: EXPLOSION HAZARD**

Do NOT energize a Hazardous Locations motor without all grease fittings properly installed.

#### 4.2.5 EXAMPLE: LUBRICATION

Assume - NEMA 286T (IEC 180), 1750 RPM Vertical motor driving an exhaust fan in an ambient temperature of 43° C and the atmosphere is moderately corrosive.

1. Table 4-1 list 10,000 hours for standard conditions.
2. Table 4-2 classifies severity of service as "Severe" with a multiplier of 0.5.
3. Table 4-3 lists a multiplier value of 0.5 for "Vertical"
4. (Eq. 4.2) Interval = 10,000 hrs x 0.5 x 0.5 = 2500 hrs

Table 4-4 shows that 1.5 in<sup>3</sup> of grease is to be added.

**Relubricate every 2,500 hrs of service with 1.5 in<sup>3</sup> of recommended grease.**

#### 4.3 TROUBLE-SHOOTING

##### **WARNING: READ INSTRUCTIONS:**

Before trouble-shooting a motor, carefully read and fully understand the warnings, cautions, & safety notice statements in this manual.

##### **WARNING: Hazardous Locations Motor Repair:**

Motors nameplated for use in Division 1 Hazardous Locations can only be disassembled, modified or repaired by the plant of manufacturer or a facility that is Listed under UL's category "Motors and Generators, Rebuilt for use in Hazardous Locations". Failure to follow these instructions could result in serious personal injury, death and/or property damage

##### **CAUTION: DISASSEMBLY APPROVAL REQUIRED:**

Motor disassembly must be performed by a party approved by the motor manufacturer. To disassemble the motor without approval voids the warranty.

##### **4.3.1 GENERAL TROUBLE-SHOOTING WARNINGS**

1. **DISCONNECT POWER TO THE MOTOR BEFORE PERFORMING SERVICE OR MAINTENANCE.**
2. **Discharge all capacitors before servicing motor.**
3. **Always keep hands and clothing away from moving parts.**
4. **Be sure required safety guards are in place before starting equipment.**
5. **If the problem persists contact the manufacturer.**

### 4.3.2 Motor Trouble-shooting Cause / Corrective Action - Table 4-5

Issue:	Likely Cause:	Corrective Action:
<b>Motor fails to start upon initial installation:</b>		
A.)	Supply voltage is too low or is severely unbalanced (one phase is low or missing).	(1) Check power supply fuses (2) Match motor lead wiring to nameplate connection diagram and supply voltage (3) Ensure that steady state supply voltage at motor terminals is within limits (see section 3.4.1.3). Correct as needed (4) Obtain correct motor to match actual supply voltage.
B.)	Motor leads are miswired at conduit box.	
C.)	Driven load exceeds motor capacity	(1) Verify that motor & load turn freely (2) Disconnect motor from load & ensure motor turns freely. Note: Roller bearings make noise when motor is uncoupled and shaft is rotated (3) Verify that motor starts when disconnected from load (4) Remove excessive / binding load if present.
D.)	Load is jammed.	
E.)	Fan guard is bent and making contact with fan	Replace fan guard & fan (if blades are damaged)
F.)	VFD with power factor capacitors installed	Remove power factor correction capacitors if equipped
G.)	VFD with motor neutral lead grounded	Ensure that motor neutral lead is ungrounded
H.)	VFD programmed incorrectly	(1) Repeat checks listed above (2) Verify that VFD current limit and starting boost are set correctly (5) Double-check motor and feedback parameter settings and VFD permissives (6) Repeat autotune (for vector drives) procedure (7) Consult VFD supplier.
<b>Motor has been running, then slow down, stalls, or fails to restart:</b>		
A.)	Supply voltage has drooped or has become severely unbalanced	(1) Replace fuse or reset circuit breaker. Allow motor to cool down before resetting manual protector on motor. <b>Warnings</b> - See section 1.1 for automatic and manual reset protector warnings (2) Verify that rated and balanced supply voltage has been restored before restarting motor. Measure voltage during restart. Ensure that steady state supply voltage at motor terminals is within limits (see section 3.4.1.3).
B.)	Motor is overloaded	(1) Verify that motor & load turn freely. Repair binding components as needed (2) Reduce driven load to match motor capacity or increase motor size to match load requirements.
C.)	Motor bearings are seized	
D.)	Load is jammed.	
E.)	VFD will not restart motor after tripping	(1) Check fault codes on VFD and follow VFD troubleshooting procedures (2) Verify that VFD input voltage is balanced and within limits (3) Remove excessive mechanical load if present.
F.)	Capacitor failure on single phase motor (if equipped)	<b>Warning: Potential Shock Hazard:</b> Contact service shop to check capacitor.
<b>Motor takes too long to accelerate:</b>		
A.)	Motor leads are not connected correctly	Match motor lead wiring to nameplate diagram.
B.)	Supply voltage has drooped or become severely unbalanced.	(1) Ensure that steady state supply voltage at motor terminals is within limits (see section 3.4.1.3). Correct as needed (2) Obtain correct motor to match actual supply voltage.
C.)	Load exceeds motor capability	Determine correct motor size and contact motor representative to obtain replacement motor.
D.)	Faulty start capacitor (Single Phase)	Motor may be too small for load. Record acceleration time. Start capacitors may fail if acceleration time exceeds 3 seconds.
E.)	Mechanical Failure	(1) Check to make sure motor & load turn freely (2) Disconnect motor from load & ensure motor turns freely
<b>Motor rotates in the wrong direction:</b>		
A.)	Incorrect wiring connection at motor	[Single Phase] Reconnect motor according to wiring schematic provided. Note: Some motors are non-reversible [Three Phase] Interchange any two power supply (phase) leads.
<b>Motor overheats or overload protector repeatedly trips</b>		
A.)	Driven Load is excessive	(1) If motor current exceeds nameplate value, ensure that driven load has not increased. Correct as needed. (2) If new motor is a replacement, verify that the rating is the same as the old motor. If previous motor was a special design, a general purpose motor may not have the correct performance.
B.)	Ambient temperature too high	Most motors are designed to operate in an ambient up to 40 °C. (See section 4.2.2 Hot Surface Caution)
C.)	Motor cooling fins and/or vent openings blocked	Remove foreign materials – clear vent openings, fan guard air inlets and frame fins (TEFC motors)
D.)	Insufficient Air Flow	TEAO (Totally Enclosed Air Over) motors: Measure airflow next to motor surface and obtain minimum requirements from motor manufacturer.

E.)	Motor is started too frequently	See section 3.4.5.3
F.)	Supply voltage too low, too high, or unbalanced	(1) Ensure that steady state supply voltage at motor terminals is within limits (see section 3.4.1.3) Correct as needed (2) Reconnect motor per input voltage (3) Obtain correct motor to match power supply.

### Motor Vibrates

A.)	Motor misaligned to load.	Realign load
B.)	Load out of balance (Direct drive application)	(1) Ensure that load is dynamically balanced: (2) Remove motor from load and inspect motor by itself. Verify that motor shaft is not bent. Rule of thumb is 0.002" runout for shafts extension lengths up to 3.00". Add 0.0005" per every additional inch of shaft length beyond 3.00".
C.)	Uneven tension on multiple belts	Mixing new with used belts. Replace multiple belt applications with a complete set of matched belts.
D.)	Driven load operating at resonant point / natural frequency.	(1) De-energize motor and record vibration as load coasts from 100% speed to 0 RPM. If vibration drops immediately, vibration source is electrical. If levels do not drop immediately, source is mechanical (2) Redesign system to operate below the resonant point (3) On VFD-driven loads, program skip frequencies to bypass resonant points (4) Increase carrier frequency to obtain <3% THD current (5) On variable torque loads reduce volts/hertz below base speed.
E.)	VFD torque pulsations	(1) Adjust VFD to obtain <3% THD current @ rated motor current (2) Adjust VFD stability for smooth operation. Vector drives may be unstable at light load.
F.)	Motor miswired at terminal box	Match motor lead wiring to nameplate connection diagram.
G.)	Uneven, weak or loose mounting support.	Shim, strengthen or tighten where required.
H.)	Motor bearings defective	Test motor by itself. If bearings are bad, you will hear noise or feel roughness. Roller bearings are normally noisy when operated without load. If sleeve bearing, add oil per nameplate instructions. For motors with regreasing provisions, add grease per relubricating instructions (see section 4.2.3). If noise persists contact warranty service.
I.)	Motor out of balance	Disconnect from load. Set motor on rubber pads on solid floor. Secure a ½ height key in shaft keyway and energize from balanced power supply @ rated voltage. Record vibration levels and compare with appropriate standards. If excessive vibration persists contact motor manufacturer.

### Bearings repeatedly fail.

A.)	Load to motor may be excessive or unbalanced	(1) If belt drive check system per section 3.3.4. (2) Other than belting, check loading on motor shaft. An unbalanced load will also cause the bearings to fail. (3) Check runouts of mating components, such as a C-face and pump flange.
B.)	Bearings contaminated.	Motor enclosure not suitable for environment. Replace with correct enclosure construction
C.)	Incorrect grease or bearings for ambient extremes.	See section 4.2.1
D.)	VFD bearing damage	Ground brush, common mode filter, or insulated bearings must be added. Contact motor manufacturer.

### Motor, at start up, makes a loud rubbing, grinding, or squealing noise.

A.)	Contact between rotating and stationary components	Belt squeal during across the line starting is normal: (1) Verify that supply voltage is within limits (see section 3.4.1.3). (2) Ensure that motor lead wiring matches nameplate connection diagram: (3) Isolate motor from load. (4) To locate point of contact turn motor shaft by hand. (5) If point of contact is not located contact motor service shop.
-----	--	--

### Start capacitors repeatedly fail.

A.)	The motor acceleration time is too long	Motor may be too small for load. Record acceleration time. Start capacitors may fail if acceleration time exceeds 3 seconds.
B.)	Motor is being started too frequently	Excessive starting will damage motor capacitors. Contact motor manufacturer if motor is started more than 20 times/hour or if acceleration time exceeds 3 seconds.
C.)	Motor voltage low	Verify that voltage at the motor terminals is within limits (see section 3.4.1.3).
D.)	Defective start switch inside motor	Motor internal switch failure overheats start capacitor. Contact service shop or motor manufacturer.

### Run capacitor fails.

A.)	High ambient temperature	Verify that the ambient does not exceed motor's nameplate value
-----	--------------------------	---

	<b>B.)</b> Input voltage exceeds limit	Verify that voltage to the motor terminals is within limits (see section 3.4.1.3).
	<b>C.)</b> Power surge to motor (caused by lightning strike or other high transient voltage).	If a common problem, install surge protector.