

# FS 25, FS 60 IN-LINE FILTERS



FS 25



FS 60

## ADVANTAGES

- Filtration is performed by a high-quality uniform mesh.
- Different mesh sizes offer optimised protection while allowing sufficient flow rates.
- Not only the pump, also the following components are protected from particulates, crystals and fibres.
- Chemical resistance guarantees a wide range of applications.

## POSSIBLE AREAS OF USE

- Equally suitable for use with either liquids or gases
- Laboratory applications (Acids, bases, solvents, alcohols and oils)

## PERFORMANCE DATA

Type	FS 25 T	FS 25 X	FS 60 T	FS 60 X
Material (housing / mesh)	PVDF	PEEK	PVDF	PEEK
Mesh opening	70 µm	35 µm	70 µm	35 µm
Max. flow rate (liquids)	250 ml/min	250 ml/min	600 ml/min	600 ml/min
Max. pressure (mH <sub>2</sub> O)	20	20	60	60
Connectors	for tubes ID 3.2 / 4 mm	for tubes ID 3.2 / 4 mm	UNF 1/4" - 28	UNF 1/4" - 28

## PART-NO.

Type	FS 25 T	FS 25 X	FS 60 T	FS 60 X
1 pce.	165211	346941	346932	323625
Pack with 10 pcs.	-	346942	346933	323626

# FS 25

## IN-LINE FILTER FS 25

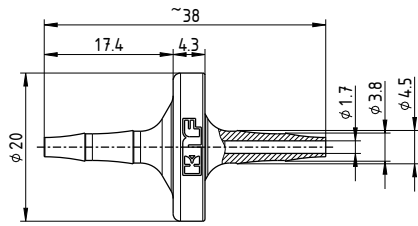

- \* Schlauch / Hose ID = Ø3.2mm
- \*\* Schlauch / Hose ID = Ø4mm

## FLOW CURVE FS 25

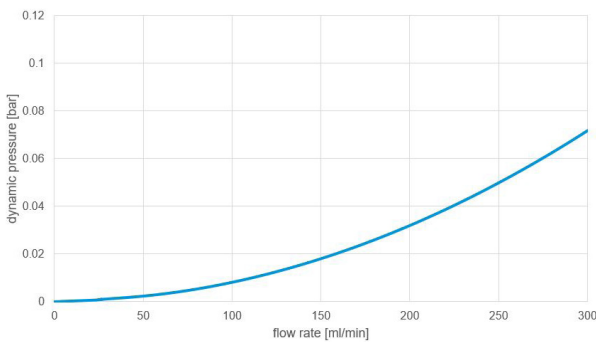

# FS 60

## IN-LINE FILTER FS 60

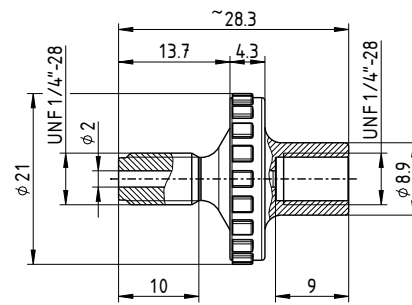

## FLOW CURVE FS 60

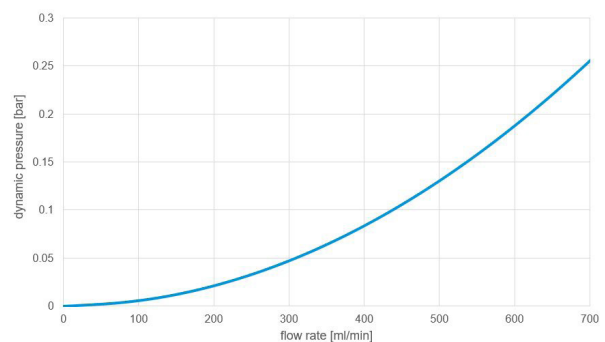

## APPLICATION INFORMATION

### Instructions for priming

When filling the system liquid, flow direction should be from bottom upwards to help air bubbles escape. Air bubbles in the system may influence the dosing accuracy.

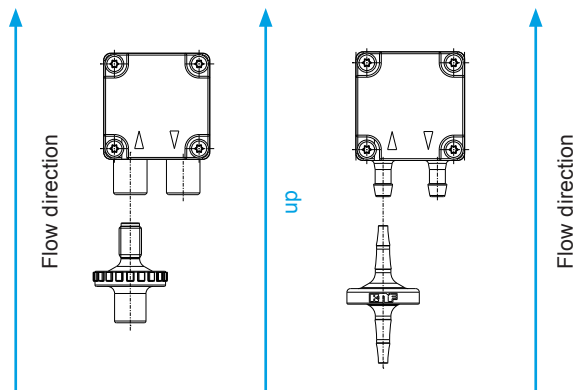

### Checking pump flowrate / differential pressure

The pump should be checked on an occasional basis for liquid containing a low proportion of particulate crystals or fibres. We recommend that you regularly monitor the differential pressure if your liquid contains a high proportion of particulate, crystals or fibres.

### Filter replacement

We recommend filter replacement on a yearly basis as a minimum, and more regularly for applications with heavy concentrations of particulates, crystals or fibres.

### Chemical resistance

Please refer to the «Chemical Resistance Chart» on our website.

The performance values for the series models shown on this data sheet were determined under test conditions. The actual performance values may differ and depend in particular on the usage conditions and therefore on the specific application, on the parameters of the components involved in the user's system and on any technical modifications carried out which deviate from the standard configuration or the as delivered condition.

If individual designs have been created for specific customers on the basis of series models, other technical performance data may apply.

Before operation begins, the relevant operating instructions and/or assembly or installation instructions should be read and the safety information contained in these instructions should be noted. KNF reserves the right to make changes to the product and the associated documentation without prior notice to the customer.



[www.knf.com](http://www.knf.com)