

FP 25

SMOOTH FLOW DIAPHRAGM LIQUID PUMP

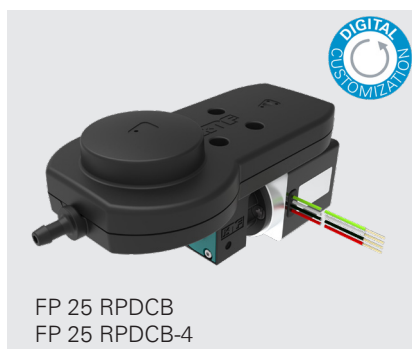

ADVANTAGES

Integrated Damper

- provides smooth flow with low pulsation
- reduces flow resistance in tubes
- prevents bubble formation
- no need for additional dampening elements

Innovative 4-point valves

- for reliable self-priming even at low motor speeds

Digitally customizable BLDC Motor

- for precise flow control and pinpoint adjustments to your electronics

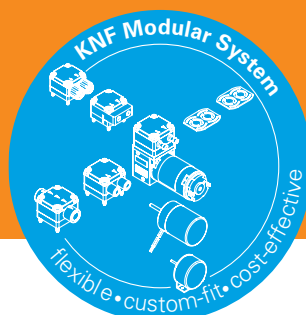

Please visit our website
www.knf.com
to get more information.

POSSIBLE AREAS OF USE

- Inkjet Printing
- Medical Equipment
- 3D Printing
- Fuel Cells
- Handling of solvents
- And many more

PERFORMANCE DATA			
Series model	FP 25 DC	FP 25 DCB*1	FP 25 DCB-4*1
Material options	RP	RT	
Pump head	PPS	PPS	
Diaphragm	EPDM	PTFE	
Valves	EPDM	FFKM	
Valve o-rings	EPDM	FKM	
Dampening diaphragm	EPDM	PTFE	
Nominal flow rate at atm. (ml/min)	250		
Suction height (mH ₂ O)	≥ 3		
Nominal pressure head (mH ₂ O)	10		
Permissible ambient temperature (°C)	+5 to +40		
Permissible liquid temperature (°C)	+5 to +80		
IP protection factor pump	00	50	50
ELECTRICAL DATA			
Operating voltage (V)	12 / 24	12 / 24	10 – 26.4
Power consumption (W)	2.9	4.3 / 4.8	4.1
I load max. (A)	0.24 / 0.12	0.36 / 0.2	0.42 – 0.15
IP protection factor motor	00	54	54
Weight (g)	240	265	265

*1 DCB = Stands for brushless DC motor

FP 25 DC

PERFORMANCE DATA

Series model	Nominal flow rate at atmos (l/min)	Suction height (mH ₂ O)	Nominal pressure head (mH ₂ O)
FP 25 DC	0.25	≥ 3	10

FP 25 DC

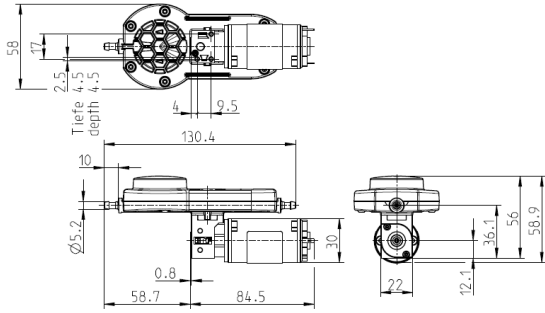

Dimensions in mm

FP 25 DCB

PERFORMANCE DATA

Series model	Nominal flow rate at atmos (l/min)	Suction height (mH ₂ O)	Nominal pressure head (mH ₂ O)
FP 25 DCB-B	0.25	≥ 3	10

FP 25 DCB

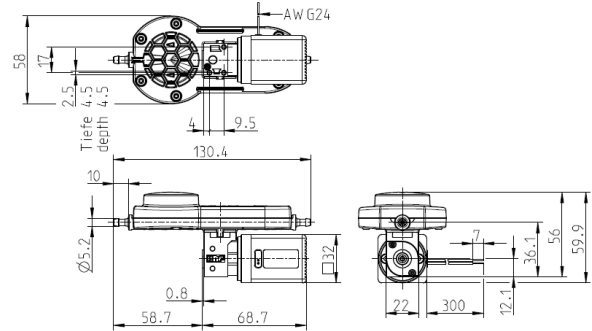

Dimensions in mm

FP 25 DC

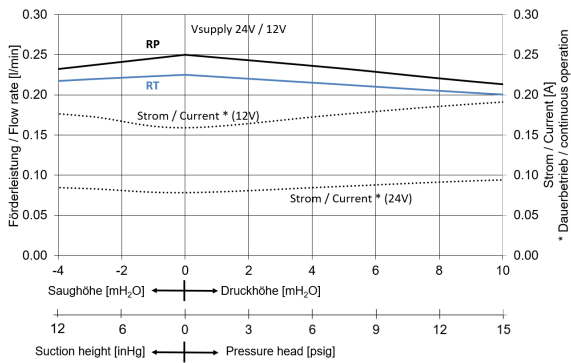

FP 25 DCB

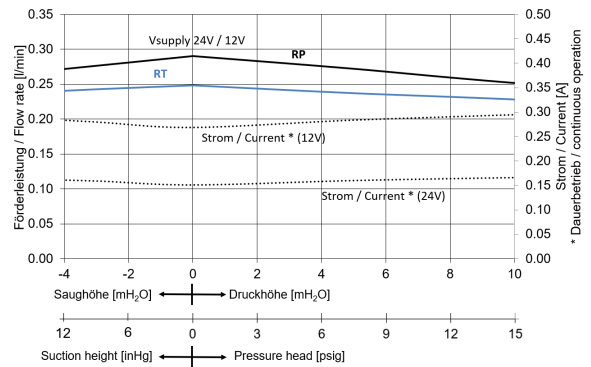

ELECTRIC SPECIFICATIONS

Wires	AWG 24
Wires assignment	red = +VS black = - VS/GND

FP 25 DCB-4

PERFORMANCE DATA

Series model	Nominal flow rate at atmos (l/min)	Suction height (mH ₂ O)	Nominal pressure head (mH ₂ O)
FP 25 DCB-4	0.25	≥ 3	10

FP 25 DCB-4

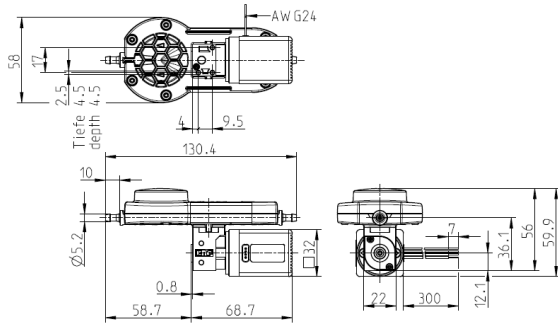

Dimensions in mm

FP 25 DCB-4

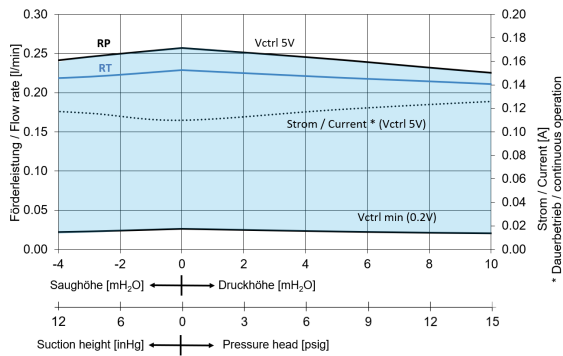

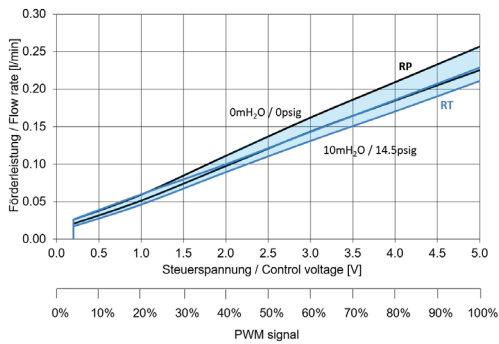

FP 25 DCB-4



ELECTRIC SPECIFICATIONS

Wires	AWG 24
Wires assignment	red = +VS black = -VS/GND white = Vctrl-input green = FG-output
Input signal	0-5 V

OPTIONS		
Description	Illustration	Details
Motors with special voltages or frequencies		Various voltage options, higher and lower service life.
Electrical connectors		Specific customers requirements such as special connections (Molex, AMP, etc.)



NSF National Sanitary Foundation

This certification will confirm that all of the pumps with the code .51 are certified for the use with foods/consumables.



DIGITAL CUSTOMIZATION

Thanks to digital technology, this pump can be quickly adapted to the customer's system. This is done by parametrizing the firmware of the motor at KNF.

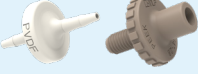
ACCESSORIES			
Description	Illustration	Part No.	Details
Diaphragm pressure control valve		on request	The pressure control valve can be used for a more accurate control of flow against a fluctuating back pressure, metering into a vacuum and from a pressurised system.
Filter		on request	KNF filters protect both pumps and other upstream instrumentation and hydraulic circuits against particulate, crystals and fibres which can improve optimum operation.

The performance values for the series models shown on this data sheet were determined under test conditions. The actual performance values may differ and depend in particular on the usage conditions and therefore on the specific application, on the parameters of the components involved in the user's system and on any technical modifications carried out which deviate from the standard configuration or the as delivered condition.

If individual designs have been created for specific customers on the basis of series models, other technical performance data may apply. Before operation begins, the relevant operating instructions and/or assembly or installation instructions should be read and the safety information contained in these instructions should be noted. KNF reserves the right to make changes to the product and the associated documentation without prior notice to the customer.



www.knf.com

KNF reserves the right to make technical changes without notice.
KNF 04/2026 www.knf.com