

# FD 1.200 DOSING PUMP



FD 1.200

## ADVANTAGES

- Precise dosing
- Robust against varying system conditions
- Bi-directional flow
- Always forward and backward flow tight
- Flexible communication interfaces
- Easy system integration
- Self-priming and run dry safe

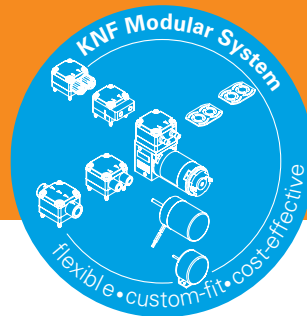

Please visit our website  
[www.knf.com](http://www.knf.com)  
to get more information.

## POSSIBLE AREAS OF USE

- Medical diagnostics
- Analytical Instruments
- Cleaning + Disinfection
- Laboratory Instruments
- Food

## PERFORMANCE DATA

Series model	FD 1.200	
Material variants	RP	RT
Pump head	PPS	PPS
Diaphragm	EPDM	PTFE
Valves	EPDM	FFKM
O-Rings	EPDM	FKM
Housing	PP	PP
Shot volume range (µl)	50 ... 200	
Max. shot frequency (shots per second)	3.33	
Max. flow rate: dosing mode (ml/min)	40	
Max. flow rate: priming mode (ml/min)	65	
Set point accuracy	+/- 2% RD	
Repeatability (CV)	≤ 0.5%	
Calibration	Calibration in factory @ 0 bar g / 25 °C with water	
Suction height, dry (mH2O / inHg)	≥ 4.5 / 13 @ 200 µl shot volume	
Max. outlet pressure head (mH2O / psig)	60 / 85	
Max. inlet pressure head (mH2O / psig)	20 / 28.5	
Permissible media temperature (°C / °F)	5 ... 80 / 41 ... 176	
Max. media temp. for hot sterilization (°C / °F)	95 / 203, for max. 40 minutes	
Permissible ambient temperature (°C / °F)	5 ... 50 / 41 ... 122	
IP protection factor	IP20 (IP54 on request)	
Weight (g)	700	
ELECTRICAL DATA		
Operating voltage (VDC)	24 +/- 10%	
Power (W)	36	
I load max (A)	1.5	

## INFLUENCE ON ACCURACY

Material Variants	RP	RT
Suction height		0 / - 2% per mH2O
Outlet pressure @ 200 µl		0 / - 0.2% per mH2O
Outlet pressure @ 50 µl (minimal shot volume)		0 / - 0.6% per mH2O
Viscosity (0.3 – 150 mPas)	0 / - 3%	0 / - 5%
Media temperature (5...80 °C)		+/- 2%
Ambient and media temperature (5...50 °C)		+/- 3%
Drift over time @ 200 µl (54 mio. cycles)		+/- 4%
Drift over time @ 50 µl (54 mio. cycles)*		+/- 8%

\* Primarily only for small target volumes of 50 µl

## FD 1.200

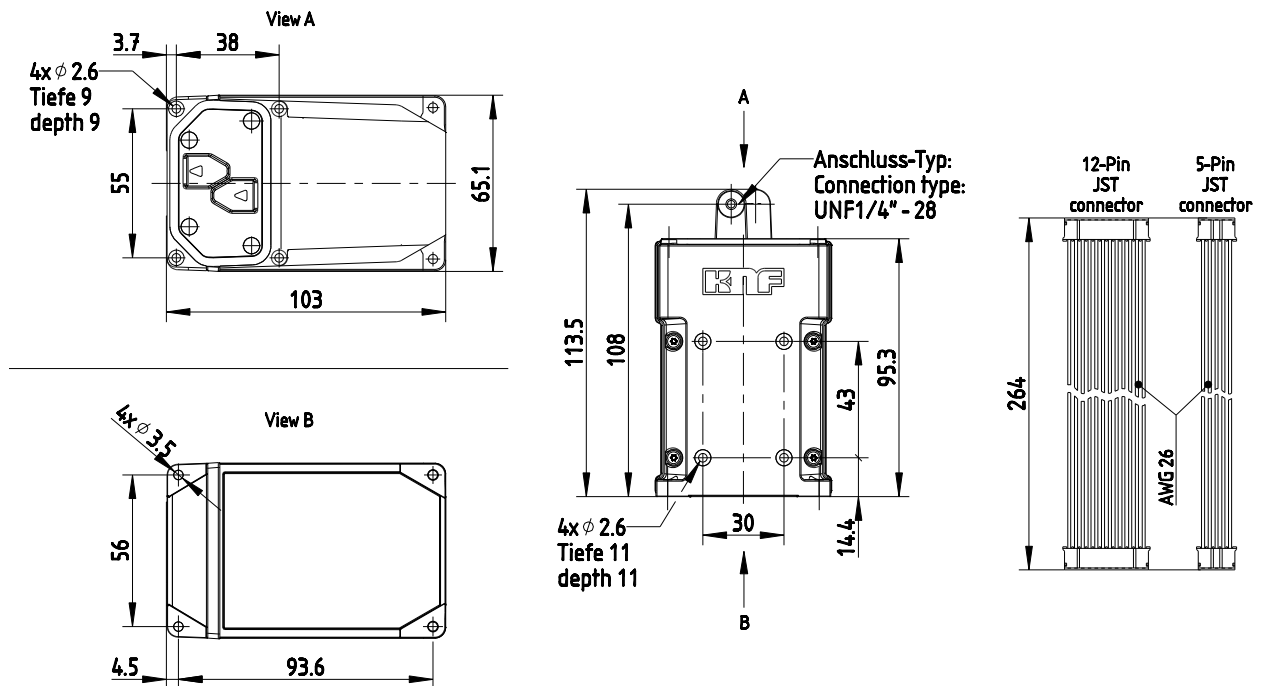

## FD 1.200

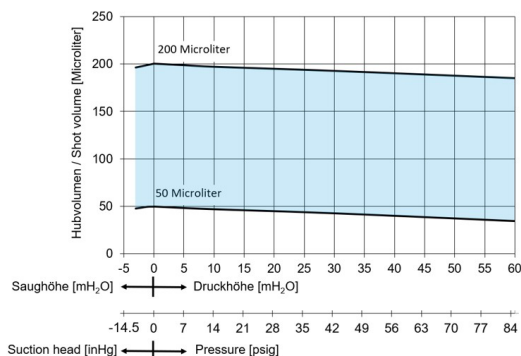

## FD 1.200

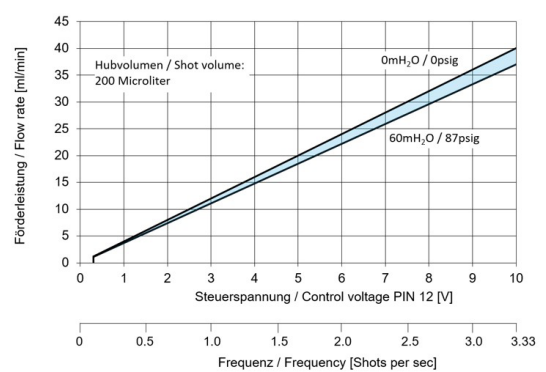



## ELECTRICAL CONNECTION

Serial Interface	UART TTL (3.3 V)			
Interface project options	UART on RS232 (on request), CAN Bus (on request)			
Socket 1 (JST, 5 pins) Manufacturer no. B5B-PH-SM4-TB	<b>Number</b>	<b>Designation</b>	<b>Function</b>	
	PIN 1	24V	Power supply	
	PIN 2	GND	GND for power supply	
	PIN 3	Serial GND	GND for serial communication	
	PIN 4	Serial COM 2	Tx (transmit)	
	PIN 5	Serial COM 1	Rx (receive)	
Socket 2 (JST, 12 pins) Manufacturer no. B12B-PH-SM4-TB	<b>Number</b>	<b>Designation</b>	<b>Type</b>	<b>Function</b>
	PIN 1	24V		Power supply
	PIN 2	GND		GND for power supply
	PIN 3	Run	Digital input	<ul style="list-style-type: none"> <li>HIGH pulse (&gt;5 ms, 5 V) starts a dosing cycle</li> <li>Permanent HIGH for continuous dosing (Ends dosing cycle as soon as LOW)</li> </ul>
	PIN 4	Reverse	Digital input	At HIGH (5 V), the pump runs in reverse. (Applies to both Run and Prime modes)
	PIN 5	Error	Digital output	HIGH (5 V) in case of fault
	PIN 6	Overpressure warning	Digital output	HIGH (5 V) when there is overpressure at the pump outlet (Default: >7 bar)
	PIN 7	Cycle complete	Digital output	HIGH pulse (10 ms, 5 V) after each dosing cycle
	PIN 8	Prime	Analog input	Prime mode (filling mode) 0.5 V = 5 ml/min (23 rpm) 6.5 V = 65 ml/min (300 rpm)
	PIN 9	GND Diff	GND Pin 10 – 12	GND (differential) for input signals PIN 10-12
	PIN 10	Suction ratio	Analog input*	Analog input 0-10 V 0.3 V = 3% (min) 9.7 V = 97% (max) Default (<0.2V): 50% **
	PIN 11	Shot volume	Analog input*	Analog input 0-10 V 1.6 V = 40 µl (min) 8.4 V = 210 µl (max) Default (< 0.2 V): 200 µl **
PIN 12	Frequency	Analog input*	Analog input 0-10V 0.3 V = 0.1 shots per sec (min) 10 V = 3.33 shots per sec (max) Default (<0.2 V): 2 shots per sec **	

\* Pin 10-12: Customizable inputs/outputs (analog input: 0-10V or PWM), default: 0-10V. For accurate dosing, it is important that the differential voltage at the input is sufficiently accurate. \*\* or value of the serial interface

## ACCESSORIES

Description	Illustration	Part No.	Details
Starter-Kit cable USB – UART TTL		358830	USB Connecting cable to parametrize the FD 1.200 System with the KNF Connect Software, open wire ends for power and control input/signal output
Filter FS 60 T PVDF FS 60 X PEEK		PVDF: 346932 PEEK: 323625	KNF filters protect both pumps and other upstream instrumentation and hydraulic circuits against particulate, crystals and fibres which can improve optimum operation. Mesh opening: PVDF: 70 µm PEEK: 35 µm

The performance values for the series models shown on this data sheet were determined under test conditions. The actual performance values may differ and depend in particular on the usage conditions and therefore on the specific application, on the parameters of the components involved in the user's system and on any technical modifications carried out which deviate from the standard configuration or the as delivered condition.

If individual designs have been created for specific customers on the basis of series models, other technical performance data may apply. Before operation begins, the relevant operating instructions and/or assembly or installation instructions should be read and the safety information contained in these instructions should be noted. KNF reserves the right to make changes to the product and the associated documentation without prior notice to the customer.



[www.knf.com](http://www.knf.com)

KNF reserves the right to make technical changes without notice.  
KNF 05/2026 [www.knf.com](http://www.knf.com)