

Swing Piston Compressors and Vacuum Pumps

NPK 25 AC
NPK 25 DC

Operating and Installation Instructions

Read and observe these Operating and Installation Instructions!

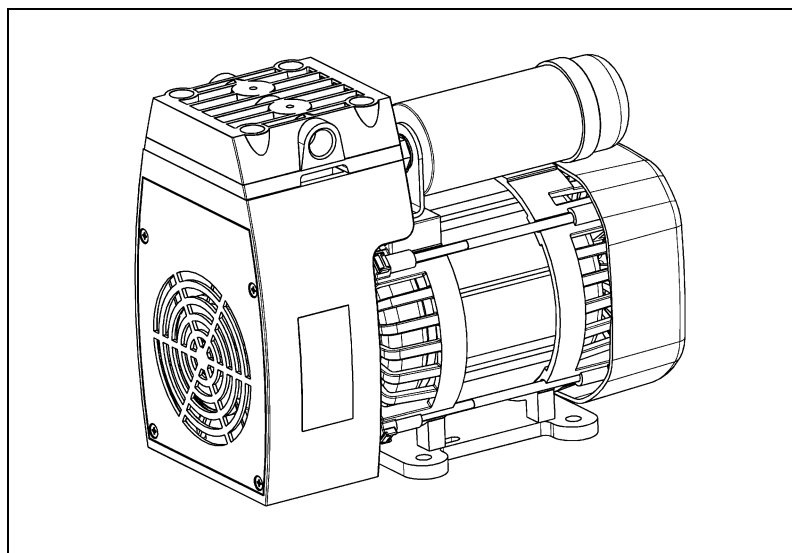

KNF Neuberger GmbH
Alter Weg 3
D-79112 Freiburg
Germany
Tel. +49-(0)7664-5909-0
Fax +49-(0)7664-5909-99

E-Mail: info@knf.de
www.knf.de

Contents	Page
1. About this document.....	2
2. Use	3
3. Safety	4
4. Technical data	6
5. Design and function.....	7
6. Installation and connection.....	8
7. Operation.....	12
8. Servicing.....	13
9. Troubleshooting.....	16
10. Spare parts and accessories.....	18
11. Returns	19

1. About this document

1.1. Using the Operating and Installation Instructions

The Operating and Installation Instructions are part of the pump.

➔ Pass on the Operating and Installation Instructions to the next owner.

Project pumps

Customer-specific project pumps (pump models which begin with "PJ" or "PM") may differ from the Operating and Installation Instructions.

➔ For project pumps, also observe the agreed upon specifications.

1.2. Symbols and markings

Warning



WARNING

A danger warning is located here.

Possible consequences of a failure to observe the warning are specified here. The signal word, e.g.

Warning, indicates the danger level.

➔ Measures for avoiding the danger and its consequences are specified here.

Danger levels

Signal word	Meaning	Consequences if not observed
DANGER	warns of immediate danger	Death or serious injuries and/or serious damage are the consequence.
WARNING	warns of possible danger	Death or serious injuries and/or serious damage are possible.
CAUTION	warns of a possibly dangerous situation	Minor injuries or damage are possible.

Tab. 1

Other information and symbols

➔ An activity to be carried out (a step) is specified here.

1. The first step of an activity to be carried out is specified here. Additional, consecutively numbered steps follow.

i This symbol refers to important information.

2. Use

2.1. Proper use

The pumps are designed for pumping air.

Owner's responsibility

Operating parameters and conditions

Only install and operate the pumps under the operating parameters and conditions described in Chapter 4, Technical data.

Requirements for transferred medium

Before using a medium, check whether the medium can be transferred danger-free in the specific application case.

When using a medium other than air: Before using a medium, check the compatibility of the materials of the pump head, swing piston and piston seal with the medium.

2.2. Improper use

The pumps may not be operated in an explosive atmosphere.

The pumps may not be used to pump combustible or potentially explosive media.

The pumps are not suitable for pumping vapors or liquids.

3. Safety

i Note the safety precautions in sections 6. *Installation and connection*, and 7. *Operation*.

The pumps are built according to the generally recognized rules of technology and in accordance with the occupational safety and accident prevention regulations. Nevertheless, dangers can result during its use which lead to injuries to the user or others, or to damage to the pump or other property.

Only use the pumps in proper technical condition and in accordance with its intended use in a safety and danger-conscious manner while observing the Operating and Installation Instructions.

Personnel Make sure that only trained and instructed personnel or specially trained personnel work on the pump. This especially applies to assembly, connection and servicing work.

Make sure that the personnel has read and understood the Operating and Installation Instructions, and in particular the "Safety" chapter.

Working in a safety-conscious manner Observe the accident prevention and safety regulations when performing any work on the pump and during operation.

Handling dangerous media When transferring dangerous media, observe the safety regulations when handling these media.

Environmental protection Store all replacement parts in a protected manner and dispose of them properly in accordance with the applicable environmental protection regulations. Observe the respective national and international regulations. This especially applies to parts contaminated with toxic substances.

EC Directives / Standards For the purposes of the Machinery Directive 2006/42/EC, pumps are "partly completed machinery," and are therefore to be regarded as not ready for use. Partly completed machinery may not be commissioned until such time as it has been determined that the machine in which the partly completed machinery is to be assembled is in conformity with the provisions of the Machinery Directive 2006/42/EC. The following essential requirements of Annex I of Directive 2006/42/EC (general principles) are applied and observed:

- General Principles No. 1
- No. 1.1.2. / 1.1.3. / 1.3.1. / 1.3.3. / 1.3.4. / 1.4.1. / 1.5.1.* / 1.5.2.* / 1.5.8. / 1.5.9. / 1.7.4. / 1.7.4.1. / 1.7.4.3.
(* only for pump type NPK 25 AC)

As these partly completed machinery are OEM-models the power supplies and the equipment for disconnecting and switching-off the partly completed machinery respectively have to be considered when mounting as well as over-current and overload protective gear.

In addition a protection against mechanical parts in motion and hot parts, if existing, has to be provided when mounting.



The pumps conform to the Directive 2011/65/EU.

The following harmonized standards have been used:

NPK 25 AC	NPK 25 DC
DIN EN 55014-1/2	DIN EN 55014-1/2
DIN EN 61000-3-2/3	DIN EN 60034-1
DIN EN 60335-1	DIN EN 50581
DIN EN 50581	

Tab. 2

Customer service and repairs

Only have repairs to the pump carried out by the KNF Customer Service responsible.

4. Technical data

Pump materials

Assembly	Material
Head plate; cylinder	Aluminium
Valve plate	Stainless steel
Piston seal	PTFE compound
O-ring	FPM
Retainer plate	Aluminium

Tab. 3

Pneumatic values

NPK 25 AC

Parameter	Value
Max. permissible operating pressure [bar g]	5
Ultimate vacuum [mbar abs.]	180
Delivery rate at atm. pressure [l/min]*	30

Tab. 4 *Liters in standard state (1,013 mbar)

NPK 25 DC

Parameter	Value
Max. permissible operating pressure [bar g]	4
Ultimate vacuum [mbar abs.]	180
Delivery rate at atm. pressure [l/min]*	25

Tab. 5 *Liters in standard state (1,013 mbar)

Electrical data

Parameter	Value
Electrical data	See type plate
Protection class	IP 20

Tab. 6

The AC motors used are fitted as standard with a thermal-switch to protect against overloading.

Other parameters

Parameter	Values
Permissible ambient temperature	+ 5 °C to + 40 °C
Permissible media temperature	+ 5 °C to + 40 °C
Gas-tightness	The gas-tightness of the pump is dependent on the medium used.*

* If you have questions about this, please contact your KNF advisor.

Tab. 7

5. Design and function

Design

- 1 Pneumactical outlet
- 2 Pneumactical inlet
- 3 Front fan cover
- 4 Pump housing
- 5 Base plate
- 6 Motor

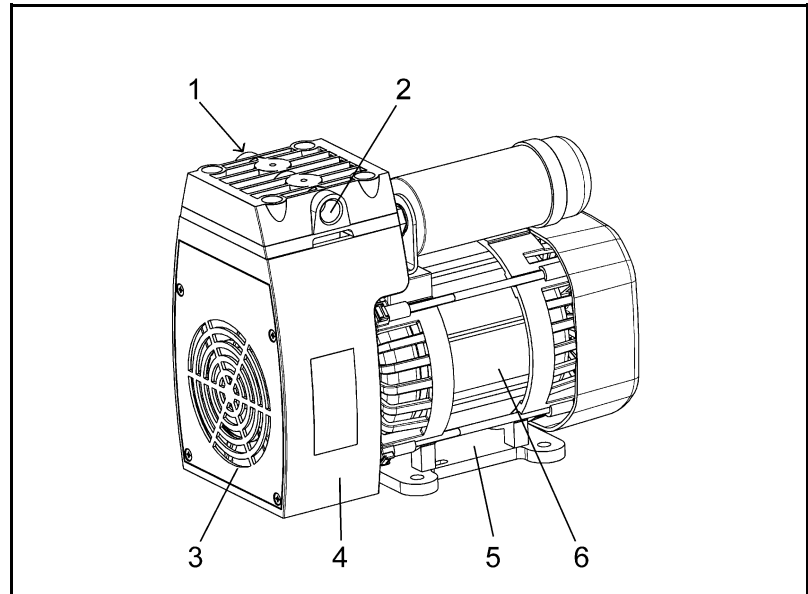

Fig. 1: Swing piston compressor and vacuum pump NPK 25 AC

Function

- 1 Inlet valve
- 2 Outlet valve
- 3 Transfer chamber
- 4 Retainer plate
- 5 Piston seal
- 6 Eccentric
- 7 Connecting rod
- 8 Compressor housing

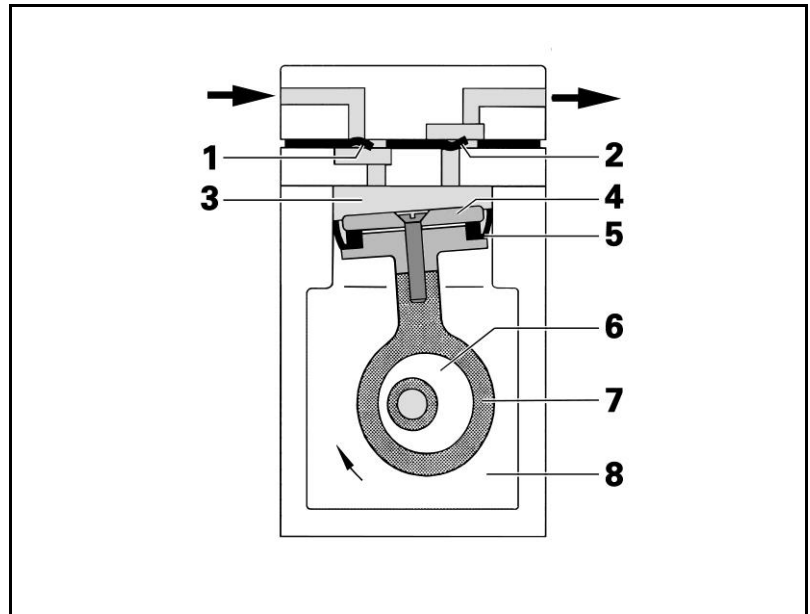

Fig. 2: Function of swing piston pump

The pumps transfer, compress and evacuate air.

The swing piston, consisting of retainer plate (4) and piston seal (5), is moved up and down by the eccentric (6) and the connecting rod (7). In the downward stroke the swing piston aspirates the medium to be transferred via the inlet valve (1). In the upward stroke, the swing piston presses the medium out of the pump head via the outlet valve (2). The swing piston is sealed off from the compressor housing by a piston seal (5) and operates oil-free.

6. Installation and connection

Only install and operate the pump under the operating parameters and conditions described in Chapter 4, Technical data.

Observe the safety precautions (see Chapter 3).

6.1. Installation

- Before installation, store the pump at the installation location to bring it up to room temperature.
 - For the mounting dimensions see fig. 3 (NPK 25 AC) or fig. 4 (NPK 25 DC)
- Mounting dimensions

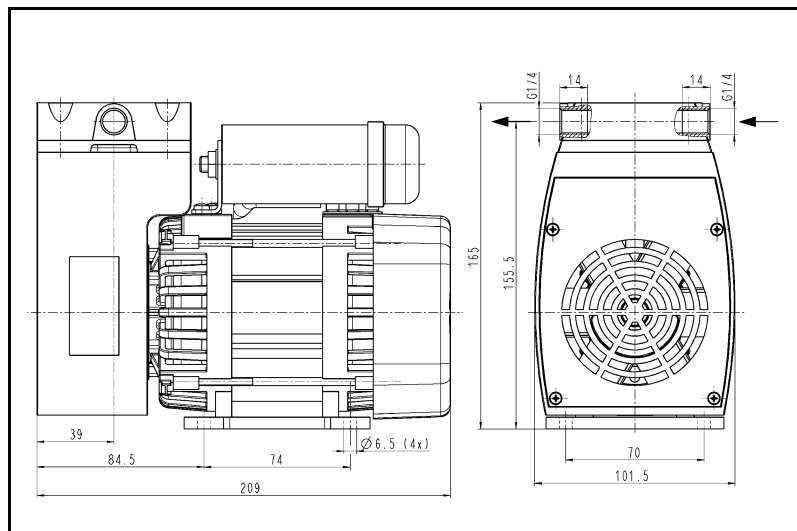

Fig. 3: Mounting dimensions NPK 25 AC
(All dimensions tolerances conform to DIN ISO 2768-1, Tolerance Class V)

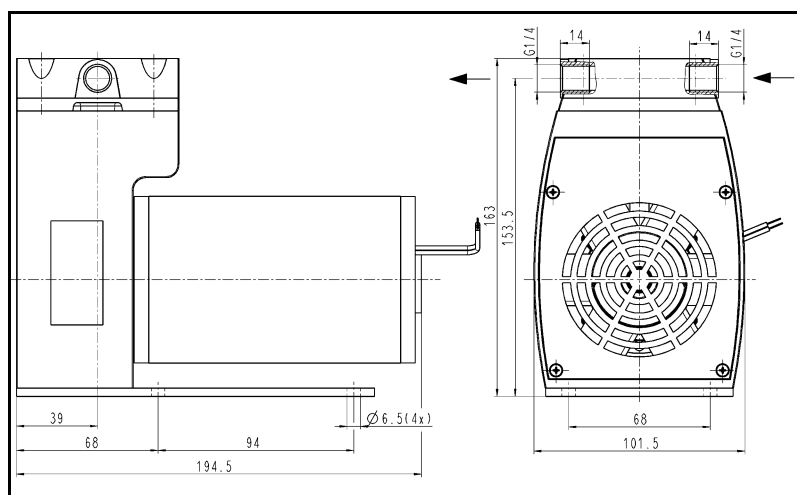

Fig. 4: Mounting dimensions NPK 25 DC
(All dimensions tolerances conform to DIN ISO 2768-1, Tolerance Class V)

Protection against touching

For pumps with AC motors:

**WARNING**

Hazard of injuries during operation

- Take protective measures against touching parts connected to electrical power (electrical connection).

Cooling air supply

- Install the pump so that the motor fan can intake sufficient cooling air.

Installation location

- Make sure that the installation location is dry and the pump is protected against rain, splash, hose and drip water.
- Install the pump at the highest point in the system to prevent condensate from collecting in the pump head.
- Protect the pump from dust.
- Protect the pump from vibrations and jolts.

6.2. Electrical connection

For pumps with AC motor:

**DANGER**

Extreme danger from electrical shock

- Only have the pump connected by an authorized specialist.
- Only have the pump connected when the power supply is disconnected.

For pumps with DC motor:

2. Only have the pump connected by an authorized specialist.
3. Only have the pump connected when the power supply is disconnected.

- In the electrical installation, arrangements (complying with EN 60335-1) must be made for disconnecting the pump motor from the electrical supply.

- For pumps with AC motors KNF recommends that a fuse is installed in the motor supply circuit (overcurrent release).



- For operating current see type plate or data sheet.

Connecting pump

1. Compare the supply data with the data on the motor-plate.



The voltage must not vary by more than + 10% and - 10% from that shown on the type-plate.

2. NPK 25 AC

Connect the mains cables to the connections L1 and N of the pump motor.

NPK 25 DC

Connect the positive and negative pole.



With DC motors, note the proper polarity:

red motor cable: +

black motor cable: -

3. Connect the earth (ground) wire to the motor (not necessary on dc motors up to 24 V).

EMC-compatible Installation (for NPK 25 DC)

The Tests:

- Magnetic field with energy-technical frequency
- Electromagnetic HF field, amplitude-modulated
- Electromagnetic HF field, pulse-modulated
- Discharging of static electricity
- High frequency, asymmetric
- Fast transients

were not carried out, cause the products do not contain electronic modules, which can be affected by these tests.

The Surge-test can only be passed with additional means, or is not mandatory, if: From EN61000-6-1 technical norm for EMC protection, part 1,10 test demands for EMC protection, table 3, EMC protection, D.C.- power in- and outputs. Remark 3: (quotation) Not to be used with input connections which are foreseen for a connection with a battery or a rechargeable battery which has to be removed or disconnected from the device for the recharge.

Devices with a D.C. power input which are foreseen to be operated with an A.C. / D.C. converter have to be tested at an A.C. power input of an A.C. / D.C. converter fixed by the manufacturer. In case the converter was not fixed they have to be tested at an A.C. power input of a typical (usual) A.C. / D.C. converter.

The test is applicable for D C power inputs which are foreseen for a permanent connection to cables which are longer than 10 m.

6.3. Pneumatic connection

- | | |
|----------------------|--|
| Connected components | → Only connect components to the pump which are designed for the pneumatic data of the pump (see Chapter 4, Technical data). |
| Pump exhaust | → If the pump is used as a vacuum pump, safely discharge the pump exhaust. |

Connecting pump

- i** A marking on the pump head shows the direction of flow.
- 4. Remove the protective plugs from the hose connection threads.
- 5. The accessory silencer/filter (where applicable) is screwed into the port thread.
- i** If the pump is used as a vacuum pump, mount the silencer at the pressure side if necessary. If the pump is used a compressor, mount the filter at the suction side if necessary.
- 6. Connect the suction line and pressure line (threadsize G ¼").
- 7. Lay the suction and pressure line at a downward angle to prevent condensate from running into the pump.

7. Operation

Only operate the pumps under the operating parameters and conditions described in Chapter 4, Technical data.

Make sure the pumps are used properly (see section 2.1).

Make sure the pumps are not used improperly (see section 2.2).

Observe the safety precautions (see Chapter 3).



WARNING

Hazard of the pump head bursting due to excessive pressure increase

- Do not exceed max. permissible operating pressure (see Chapter 4, Technical data).
- Only throttle or regulate the air quantity (the gas quantity) in the suction line to prevent the maximum permissible operating pressure from being exceeded.
- If the air quantity (the gas quantity) in the pressure line is throttled or regulated, make sure that the maximum permissible operating pressure is not exceeded.
- Monitor pressure during operation.
- If the pressure exceeds the maximum permissible operating pressure of the pump, immediately switch off pump and eliminate fault (see Chapter 9. Troubleshooting).

i Excessive pressure (with all of the related hazards) can be prevented by placing a bypass line with a pressure-relief valve between the pressure and suction sides of the pump or by a pressure-relief valve. For further information, contact our technical adviser (see front page for telephone number).

Pump standstill → With the pump at a standstill, open pressure and suction lines to normal atmospheric pressure.

Thermal switch For pumps with thermal switch: When the operation of the pump is interrupted by the thermal switch, the pump will restart automatically after cooling down.
 → Take all necessary care to prevent this leading to a dangerous situation.

Silencer/filter Change the silencer/filter (accessory) if it is dirty.

Switching pump on **i** The pump may not start up against pressure or vacuum during switch-on. This also applies in operation following a brief power failure.
 → Make sure that normal atmospheric pressure is present in the lines during switch-on.

8. Servicing

8.1. Servicing schedule

Component	Servicing interval
Pump	- Regular inspection for external damage or leaks
Piston seal and valve plate	- Replace at the latest, when pump output decreases

Tab. 8

8.2. Cleaning

- Only use solvents for cleaning if the head materials cannot be attacked (check the resistance of the material).
- If compressed air is available, blow out the components.

8.3. Replacing piston seal and valve plate

- | | |
|--------------------------|---|
| Conditions | <ul style="list-style-type: none"> ▪ Motor disconnected from mains and de-energized ▪ Pump free of dangerous substances |
| Information on procedure | <ul style="list-style-type: none"> → Always replace the piston seal and valve plate together to maintain the pump performance. |

Spare parts

Spare part*	Position**	Quantity
Piston seal	(9)	1
Valve plate	(4)	1
Countersunk screw	(7)	1
O-ring D 32 x 2.0	(3), (5)	4
O-ring D 8.0 x 1.0	(8)	1
O-ring D 50 x 2.0	(12)	1

* According to spare parts list, chapter 10

** According to Fig. 5.

Tab. 9

Tools and material

Quantity	Tools/Material
1	Phillips screwdriver No. 1 (only for pump NPK 25 DC)
1	Phillips screwdriver No. 2
1	Screwdriver blade width 5.5 mm
1	Allen key 4 mm
1	Felt-tip pen

Tab. 10

Preparatory step

1. Remove the front fan cover (Fig. 1/3, see page 6) of the pump after loosening the four fixing screws.

Front fan is visible.

Removing pump head

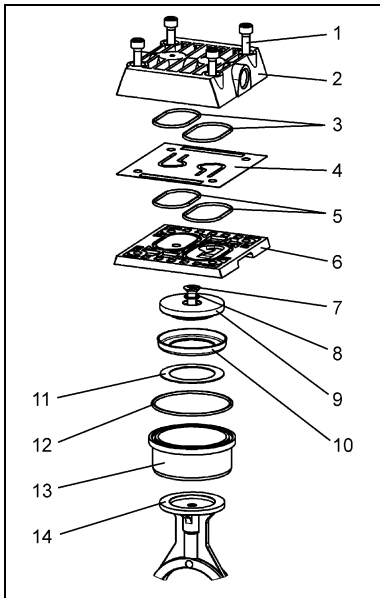

Fig. 5: NPK 25 AC / NPK 25 DC:
Parts of pump head

1. Mark the position of head plate (2), intermediate plate (6) and pump housing relatively to each other by a drawing line with a felt-tip pen to ensure proper assembly.
2. Unscrew the four screws (1) and remove the head plate (2).
3. Remove the valve plate (4) from the intermediate plate (6).
4. Remove the intermediate plate (6).
5. Remove O-rings (5) from intermediate plate (6).
6. Remove O-rings (3) from head plate (2).
7. Check the intermediate plate (6) and head plate (2) for soiling and damage. Clean the parts if necessary.
8. Contact KNF in case of roughness, scratches and corrosion. Order and replace damaged parts.
9. Move the retainer plate (9) to the upper point by turning the fan.
10. Pull cylinder (13) upwards.
11. Remove O-ring (12) from cylinder (13).
12. Hold on fan while loosening the countersunk screw (7) of retainer plate (9).
13. Remove countersunk screw (7), O-Ring (8), retainer plate (9) with piston seal (10).
14. Remove piston seal (10) from retainer plate (9).
15. Remove spacer(s) (11) from connecting rod (14).
16. Dispose of the old piston seal (10), valve plate (4), countersunk screw (7) and O-rings properly.

Mounting pump head

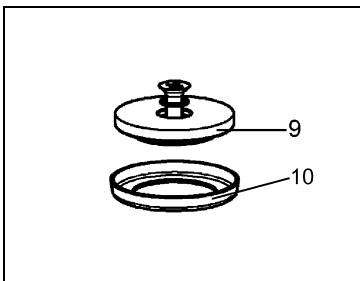

Fig. 6: Orientation of piston seal (10) in relation to retainer plate (9)

1. Hold the connecting rod (14) from the front through the fan opening, and replace the cylinder (13) on the pump housing.
2. Lay new O-ring (12) on cylinder (13).
3. Re-assemble the "piston-assembly":
 - a. Lay the new piston seal (10) on the retainer plate (9).
i For orientation of piston seal (10) see fig. 6.
 - b. Fit new O-ring (8) onto new countersunk screw (7).
 - c. Push the new countersunk screw (7) with new O-ring (8) through the retainer plate (9).
4. Fit the same number of washer(s) (11) as previously used on connecting rod (14).

5. Slide "piston assembly" (consisting of retainer plate **(9)**, piston seal **(10)**, and countersunk screw **(7)** with O-ring **(8)**) into the cylinder **(13)** from the top and place on connecting rod **(14)**.
i The piston seal must not be distorted during assembly. It must make contact with the cylinder all round its circumference
6. Fasten the "piston assembly" by tightening the countersunk screw **(7)** (maximum tightening torque: 6.5 Nm).
7. Lay the two new O-rings **(5)** on intermediate plate **(6)**.
8. Place the intermediate plate **(6)** on the pump housing in accordance with the felt-tip pen marking.
9. Place valve plate **(4)** on intermediate plate **(6)**.
i To align the valve plate, refer to fig. 5 and a groove in the intermediate plate and valve plate: The two grooves must lie on top of each other.
10. Insert the two new O-rings **(3)** into the underside of head plate **(2)**.
11. Place head plate **(2)** on intermediate plate **(6)**.
i Head plate and intermediate plate have a notch each which must lay one upon the other.
12. Tighten the screws **(1)** at first lightly, then firmly by hand, in a diagonal pattern (max. tightening torque 6.5 Nm).

Final step

1. Refit front fan cover.

9. Troubleshooting

NPK 25 AC:



Extreme danger from electrical shock!

→ Disconnect the pump power supply before working on the pump.

DANGER

→ Make sure the pump is deenergized and secure.

NPK 25 DC:

→ Disconnect the pump power supply before working on the pump.

→ Make sure the pump is deenergized and secure.

All pumps:

Check the pump (see Tab. 11 and 12).

Pump does not transfer	
Cause	Fault remedy
Thermal switch has operated following to over-heating.	<ul style="list-style-type: none"> → Disconnect pump from mains. → Allow pump to cool. → Trace cause of over-heating and eliminate it.
Connections or lines blocked.	<ul style="list-style-type: none"> → Check connections and lines. → Remove blockage.
External valve is closed or filter is clogged.	<ul style="list-style-type: none"> → Check external valves and filters.
Condensate has collected in pump head.	<ul style="list-style-type: none"> → Install pump at highest point in system.
Piston seal or valve plate is worn.	<ul style="list-style-type: none"> → Change piston seal and valve plate (see section 8.3).

Tab. 11

The pump does not achieve the output (flow, pressure or vacuum) specified in the Technical data or the data sheet	
Cause	Fault remedy
Condensate has collected in pump head.	<ul style="list-style-type: none"> → Install pump at highest point in system.
There is gauge pressure on pressure side and at the same time vacuum or a pressure above atmospheric pressure on suction side.	<ul style="list-style-type: none"> → Change the pressure conditions.
Pneumatic lines or connection parts have an insufficient cross section.	<ul style="list-style-type: none"> → Disconnect pump from system to determine output values. → Eliminate throttling (e.g. valve) if necessary. → Use lines or connection parts with larger cross section if necessary.
Leaks occur on connections, lines or pump head.	<ul style="list-style-type: none"> → Eliminate leaks.
Connections or lines completely or partially jammed.	<ul style="list-style-type: none"> → Check connections and lines. → Remove the jamming parts and particles.

The pump does not achieve the output (flow, pressure or vacuum) specified in the Technical data or the data sheet	
Cause	Fault remedy
Head parts are soiled.	→ Clean head components.
Piston seal or valve plate is worn.	→ Change piston seal and valve plate (see section 8.3).

Tab. 12

Fault cannot be rectified

If you are unable to determine any of the specified causes, send the pump to KNF Customer Service (see last page for the address).

1. Flush the pump to free the pump head of dangerous gases. For this purpose, flush the pump under atmospheric conditions some minutes with air (if necessary for safety reasons: with an inert gas).
2. Remove the pump.
3. Clean the pump (see Section 8.2)
4. Send the pump, together with completed Health and Safety Clearance and Decontamination Form, to KNF stating the nature of the transferred medium.

10. Spare parts and accessories

Spare parts

Spare part	Position*	Order No.
Piston seal	(10)	112635
Valve plate	(4)	113984
Countersunk screw	(7)	110712
O-ring D 32 x 2.0	(3), (5)	116407
O-ring D 8.0 x 1.0	(8)	116408
O-ring D 50 x 2.0	(12)	006709

Tab. 13

*according to Fig. 5

Accessories

Accessory	Order No.
Silencer/filter	007007
Hose connector*	000362
Sealing for hose connector	001818

Tab. 14

* requires Sealing for hose connector Order No. 001818

11. Returns

Prerequisite for repairing a pump by KNF is a completed Decontamination Form.

This is made available on the KNF website as a download. To find the form, select your country on the overview page (www.knf.com). You can find the Decontamination Form in the download area.

If you have questions, please contact your sales partner (contact data: see www.knf.com).

KNF worldwide

Find your local KNF partner on www.knf.com