

Operating and Installation Instructions

Swing Piston Compressors

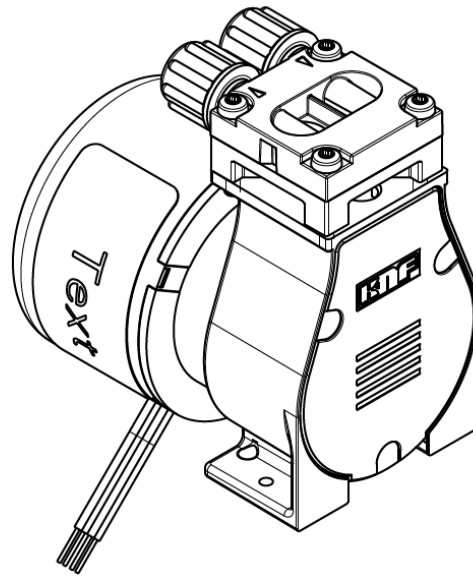

Type range:

NPK 03 KV DC-B		
NPK 03 KV DC-B4		

You have selected a high-quality KNF product; the following tips will help you operate it safely, and reliably over a long period of time. Carefully study the Operating and Installation Instructions before using the pumps and observe at all times the relevant instructions to avoid dangerous situations. The manual was produced for the serial pumps stated above. With customer-specified projects (pump types starting with "PJM" or "PMM") there could be differences in detail. For customer-specified projects please therefore take into account any agreed technical specifications, as well as these instructions.



**Product centre for
micro pumps**

KNF Micro AG
Zelglimatte 1b
CH-6260 Reiden
Switzerland
Tel. +41(0) 62 787 88 88
www.knf.com

Contents

	Page
1. About this document.....	2
2. Use	3
3. Safety	4
4. Technical data	6
5. Assembly and function	8
6. Operation.....	10
7. Servicing.....	12
8. Troubleshooting.....	13
9. Returns	14

1. About this document

1.1. Use of the Operating and Installation Instructions

The Operating and Installation Instructions are part of the pump.

- ➔ Forward the Operating and Installation Instructions to any subsequent owners of the pump

Project pumps

Customer-specific project pumps (pump models which begin with "PJM" or "PMM") may differ from the Operating and Installation Instructions.

- ➔ In the case of project pumps, take note of any additionally agreed specifications.

1.2. Symbols and markings

Warning



WARNING

This symbol indicates a potential danger.

It also indicates the possible consequences of failure to observe the warning. The signal word (e.g. "Warning") indicates the level of danger

- ➔ Here you will see actions for avoiding the danger and potential consequences.

Danger levels

Signal word	Meaning	Consequences if not observed
DANGER	warns of immediate danger	Consequences are death or serious injury and/or serious property damage.
WARNING	warns of potential danger	Death or serious injury and/or serious damage to property are possible
CAUTION	warns of a potentially dangerous situation	Minor injury or damage to property are possible.

Tab. 1

Other information and symbols

- ➔ This indicates a required activity (step).
- 1. This indicates the first step of a required activity. Additional consecutively numbered steps follow

i This symbol indicates important information

2. Use

2.1. Intended use

KNF pumps are to transfer, evacuate and compress gases.

Owner's responsibility

Operating parameters and conditions

Only install and operate the pumps under the operating parameters and conditions described in Chapter 4, Technical data. Only completely installed pumps may be taken into service.

Requirements for transferred medium

Before using a medium, check whether the medium can be transferred danger-free in the specific application case.

Before using a medium, check the compatibility of the materials of the pump head, pump housing, piston seal, piston screw and valves with the medium.

The temperature of the medium must lie within the permissible temperature range (see Chapter 4).

The transferred gas should not contain particles as these can prevent the pump from working correctly. If this cannot be guaranteed, a filter < 50 µm with sufficiently large filter area must be used upstream of the pump.

See the type- plate or data sheet for full electrical and pneumatic data.

2.2. Improper use



DANGER

The pumps must not be operated in an explosive atmosphere.

The pumps are not suitable for transferring dusts and liquids.



i Please contact your local KNF partner for special designs that are not included in the technical specification.

3. Safety

i Observe the safety precautions in Chapters 5. Installation and connection and 6. Operation.

The pumps are built according to the generally recognized rules of technology and in accordance with the pertinent occupational safety and accident prevention regulations. Nevertheless, dangers may occur during their use which may lead to injuries to the user or others, or to damage to the pump or other property.

Only use the pumps when they are in a good technical and proper working order, in accordance with their intended use, observing the safety advice within the Operating and Installation Instructions, at all times.

Personnel	<p>Make sure that only trained and instructed personnel or specially trained personnel work on the pumps. This especially applies to assembly, connection and servicing work.</p> <p>Make sure that all personnel have read and understood the Operating and Installation Instructions, and in particular the "Safety" chapter.</p>
Working in a safety-conscious manner	Always ensure adherence to all pertinent accident prevention and safety regulations when working on and operating the pump.
Handling dangerous media	When transferring dangerous media, observe the safety regulations for handling such media.
Notes	Always ensure adherence to all information stickers on the pumps, such as flow direction arrows and type plates, and keep stickers in legible condition.
Environmental protection	All replacement parts should be properly stored and disposed of in accordance with the applicable environmental protection regulations. Observe the respective national and international regulations. This especially applies to parts contaminated with toxic substances.
Disposal	<p>Dispose of all packaging in an environmentally-appropriate manner. The packaging materials are recyclable. </p> <p>Dispose of end-of-life equipment in an environmentally friendly manner. Use appropriate waste collection systems for the disposal of end-of-life equipment. Used pumps contain valuable recyclable materials. </p>
EU directives/standards	<p>For the purposes of the Machinery Directive 2006/42/EC, pumps are "partly completed machinery", and are therefore to be regarded as not ready for use. Partly completed machinery may not be commissioned until such time as it has been determined that the machine in which the partly completed machinery is to be assembled conforms to the provisions of the Machinery Directive 2006/42/EC. The essential requirements of Annex I of Directive 2006/42/EC (general principles) are applied and observed.</p> <ul style="list-style-type: none"> - General Principles No. 1 <p>No. 1.1.2. / 1.1.3. / 1.3.1. / 1.3.3. / 1.3.4. / 1.4.1. 1.5.1 / 1.5.2 / 1.5.8. / 1.5.9. / 1.7.4. / 1.7.4.1. / 1.7.4.3.</p>

As these partly completed machinery are OEM-models the power supplies and the equipment for disconnecting and switching-off the partly completed machinery respectively have to be considered when mounting as well as over-current and overload protective gear.

In addition a protection against mechanical parts in motion, hot parts, if existing, has to be provided when mounting.

The pumps comply with the fundamental requirements of Directive 2011/65/EU (RoHS2).

Customer service and repairs

All repairs to the pump(s) must be carried out by the relevant KNF customer service team.

Exception service interval: see 7.3.

4. Technical data

General parameters

Parameter	Value
Allowed ambient temperature (°C)	+5°C to + 40°C
Allowed medium temperature (°C)	+5°C to + 40°C
Allowed storage temperature (°C)	- 20°C to + 70°C

Tab. 3

Pump Materials of gas-contacting parts

Type designation NPK 03 KV ..

Components	Material ¹⁾
Head plate, intermediate plate	PPS
Valve plate	FPM
O-ring	FPM
Sealing lid	PTFE
Clamping disc	Aluminium
Clamping disc screw	A4 (stainless steel)

Tab. 4

DC-B stands for NPK 03 KV DC-B

B: Brushless motor with internal electronic – 2 wires

Motor specification		
Supply voltage[V] ⁵⁾	12	24
Max power consumption [W]	19.2	19.2
Connection[-]	Wires AWG26	
Protection class [-]	IP 20	
Weight ¹⁾ [g]	440	
Delivery rate [l/min] ^{2), 3)}	3	
Max. operating pressure [bar g] ^{2), 3)}	5.5	
Max. vacuum [mbar abs] ^{2), 3)}	250	

Tab.5

DC-B4 stands for NPK 03 KVDC-B4 (brushless)

B4: Brushless motor with internal electronic – 4 wires

Motor Variants		
Supply voltage[V] ⁵⁾	12	24
Max. power consumption [mW]	14	14
Connection [-]	Wires AWG24	
Protection class [-]	IP 20	
Weight ¹⁾ [g]	380	
Delivery rate [l/min] ^{2), 3)}	2.7	
Max. operating pressure [bar g] ^{2), 3)}	5.5	
Max. vacuum [mbar abs] ^{2), 3)}	250	

Tab.6

¹⁾ The weight may differ slightly from the stated value, depending on the version.

²⁾ Depending on the application level (MASL), ambient temperature, material design of the pump head and the connection hoses used, the flow rates may vary from the values shown.

³⁾ Measured with air at 20°C / at atmospheric pressure

⁵⁾ Nominal use

Motor electrical specifications DC-B4 12V / 24V

Electrical connections			
Function	Lead color	Signal name	Size
+ Supply voltage	Red	+ Vs	AWG 24
- Supply voltage	Blue	- Vs / GND	AWG 24
Speed control – input signal	White	Vctrl	AWG 24
Frequency output – output signal	Green	FG	AWG 24
DC control input Vctrl			
Control voltage range DC		0...5	[VDC]
Speed range		950 .. 2850	[1/min]
Resistant to surge voltages up to		30	[VDC]
Threshold voltage		1.0	[VDC]
Speed/voltage constants		950	[rpm/V]
FG frequency output			
FG pulses per mech. revolution		6	[]
Output level "high" (Iout <0.1mA)		4.2 ... 5.4	[V]
Output level "low" (Iout <0.1mA)		< 0.5	[V]

Tab.7

5. Assembly and function

Only install the pump under the operating parameters and conditions described in Chapter 4, Technical data.

Observe the safety precautions (see Chapter 3).

5.1. Installation

Installation location

- Before installation, store the pump at the installation location to bring it up to ambient
- Make sure that the installation location is dry and the pump is protected against water in the form of rain, spray, splashes and drips.
- Protect the pump against dust.
- Protect the pump against vibration and impact.

Contact and foreign body protection



WARNING

Risk of physical injury and damage to the pump due to automatic start

- If the pump overheats and the thermal switch / electronics stops pump operation, the pumps will restart automatically as soon as the motor has had time to cool down.

Take steps to ensure that this cannot produce a hazardous situation

5.2. Electrical connection

- Only have the pump connected by an authorized specialist
- Only have the pump connected when the power supply is disconnected.
- When connecting the device to a power source, the relevant norms, directives, regulations and technical standards must be observed

Connecting the pump

1. Make sure that the power supply data match the data on the motor's type plate. The current consumption can be found on the type plate.
2. Connect the motor cables. For electrical data see Chapter 4.



Note the proper polarity.

For DC motors:

red motor cable: +

black motor cable: -

In the case of brushless DC motors:

incorrect polarity may damage to the electronics.

5.3. Pneumatic connection

- Connected components → Only connect components to the pump that are designed to handle the pneumatic data of the pump (see Chapter 4, Technical data)
- Hoses → Only use hoses that are suitable for the maximum operating pressure of the pump (see Chapter 4)
- Only use hoses that are chemically resistant to the media being pumped

5.3.1. Connecting the pump



Arrows on the pump head indicate the flow direction.

1. Remove the protective caps from the hose connections.
2. Connect the suction and pressure lines.
3. If the pump is used to build up pressure, make sure that all transition joints between hose and pump are secure in order to ensure that the hoses cannot come off.
4. Check that the hoses and transition joints (hose connector/hose) are fitted correctly and securely.
5. Check that the system is leak-tight.

5.4. Fixation

The pump offers two mounting points, which allow an easy fixation of the pump with 2x DIN 912 M2.5 or 2x DIN 912 M4 screws.

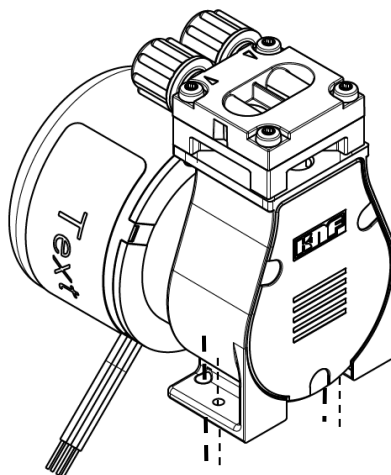

6. Operation

- Operate the pumps only under the operating parameters and conditions described in Chapter 4, Technical data
- Make sure that the pumps are being used properly (see Chapter 2.1).
- Avoid improper use of the pumps (see Chapter 2.2)
- Observe the safety precautions (see Chapter 3).
- The pump is a component intended to be incorporated into another machine. Before putting into service it must be established that the machinery or systems in which the pump is installed meets the relevant regulations



Risk of burning

The drive heats up.

- Avoid contact with the pump drive.

CAUTION

- Avoid contact with flammable materials

- i** Excessive pressure and the inherent dangers thereof can be prevented by placing a bypass line with a pressure relief valve between the pressure and suction side of the pump. Please contact your local KNF partner for further information (www.knf.com).

- Pump standstill
- If the pump stops running, restore the system to normal atmospheric pressure.

For pumps with thermal switch or electronic overload protection:



WARNING

Risk of physical injury and damage to the pump due to automatic start

If the pump overheats and pump operation is stopped by the thermal switch / electronics, the pumps will restart automatically as soon as the motor has had time to cool down

- Take steps to ensure that this cannot produce a hazardous situation

- Inspection
- Regularly inspect the pump for external damage or leaks.

Switching the pumps on

- In order to guarantee that the pump can start every time it is advisable to reduce the back pressure to an acceptable level. This is also the case if there is a short power cut.

i For more specific information contact the KNF specialist

Switching the pumps off

- Ensure that the system is subject to normal atmospheric pressure (release the hydraulic pressure).

Setting and regulating motor speed

- The motor speed of the pump, and thus the flow rate, is adjustable and can also be regulated to some extent.
- For more details, see Chapter 4, Technical data

Duty cycle / impulse operation

Duty cycle For pressures above 2bar g the switch-on duration has to be limited.

Above 2bar g, we recommend a max. switch-on duration of 5 min. The switch-on/off time depends on the heat in the pump head and its heat dissipation / cooling down while switched off.

During operation, a maximum temperature of 105°C should not be exceeded in the pump head. The temperature has to be measured on the pressure side of the pump head.

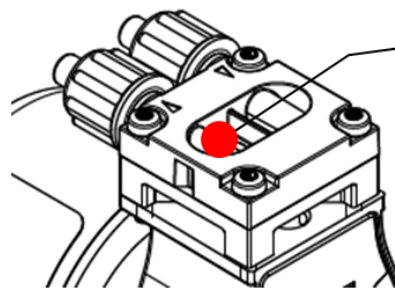

Measurement position for highest temperature, pressure side

For more specific information contact the KNF specialist

Contact information: www.knf.com

Impulse operation

Short start and stop cycles may adversely affect the service life of the brushed motors

i If the pump is operated with short cycles in your application, please contact a KNF pump specialist for further information (Telephone number: www.knf.com)

7. Servicing

7.1. Servicing schedule

Component	Servicing interval
Pump	- Regular inspection for external damage or leaks

Tab. 9

7.2. Cleaning

→ The pump, if necessary clean outside with a dry wipe. Do not use cleaning solvents as these may corrode plastic parts.

Prior requirements

- Isolate the pump from the power supply.
- Pump must be free of any hazardous substances
- Hoses must be disconnected from the pump

7.3. Service Intervall

The recommended service interval is 5000hr.

For Service: Spare part kit 314101 is available

Contained parts:

- Sealing lid 1pcs.
- O-Ring 2pcs.
- Valve plate 2pcs.
- Clamping disc screw 1pcs.

Operational manual see is enclosed at spare part kit.

i Please note, spacers below clamping disc and con rod have to be secured. Same spacers have to be reused.

Otherwise function is not guaranteed

8. Troubleshooting

Pump does not work	
Cause	Fault remedy
Pump not connected to power supply	→ Connect pump to power supply
Power supply is not switched on	→ Switch on power supply
Thermal switch or pump electronics have responded	→ Disconnect pump from mains power supply. → Allow pump to cool. → Identify and eliminate cause of overheating/overload
Connections or pipes are blocked.	→ Check pipes and connections. → Remove blockage.
External valve is closed or filter is blocked	→ Check external valves and filters.
Sealing lid, valves or gaskets are worn out	→ Service according 7.3 → Contact customer service

Tab. 10

Flow rate, pressure or vacuum too low	
The pump does not achieve the output specified in the Technical data or the data sheet	
Cause.	Fault remedy
Components in the system connected to the suction and pressure sides, such as hoses, valves or filters, are causing too much resistance	→ Modify installation, check the cross-sections of components
Hose connections are not leak tight	→ Secure transition joints between hose and hose connections → with clamps or clamping elements
Particles in the pump	→ Clean the pump head, install suction-side filter if required
Incorrect interchange of pressure and suction line connections	→ Remove pressure and suction lines and reconnect correctly
The pump parts are not resistant to the medium to be transferred	→ Replace the pump head with a compatible version
Sealing lid, valves or gaskets are worn out	→ Service according 7.3 → Contact customer service

Tab. 11

Fault cannot be rectified

If you are unable to identify any of the above causes, please send the pump to KNF customer service (see address on last page).

1. Isolate the pump from the power supply and remove the pump from the system.
2. Clean the pump (see Chapter 7.2)
3. Send the pump, with completed decontamination declaration (see Chapter 9), to KNF customer service stating the nature of the transferred medium.

9. Returns

Preparing for return

1. Flush the pump with air for a few minutes (if necessary for safety reasons: with inert gas) to free the pump head of dangerous or aggressive gases (see Chapter Flushing the pump).

i Please contact your KNF sales partner if the pump cannot be flushed due to damages

2. Remove the pump.
3. Clean the pump (see the Chapter Cleaning the pump).
4. Send the pump together with completed Health and Safety Clearance and Decontamination Form to KNF, stating the nature of the transferred medium.
5. Package the device securely to prevent further damage to the product. If necessary, request an original packaging at a charge.

Returns

KNF shall undertake to repair the pump only under the condition that the customer presents a certificate regarding the medium that is pumped and the cleaning of the pump. Please follow the instructions at knf.com/repairs.

Contact your KNF sales partner directly if you require additional support for your return service.

KNF worldwide

Find our local KNF partner on: www.knf.com



