

**ATEX**

**N87.9 EX  
TRANSLATION OF ORIGINAL OPERATION AND  
INSTALLATION INSTRUCTION  
ENGLISH**

# DIAPHRAGM PUMP

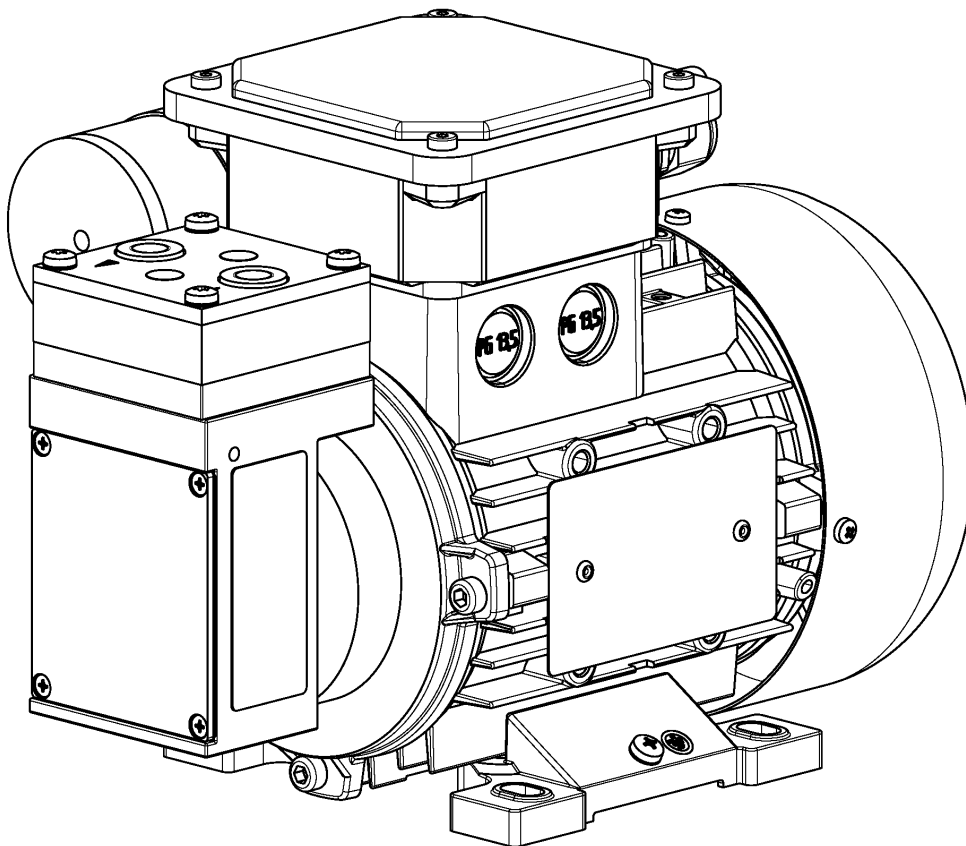

**Notice!**

Before operating the pump and accessories, read and observe the operating and installation instructions as well as the safety information!

KNF Neuberger GmbH  
Alter Weg 3  
79112 Freiburg  
Germany  
Tel. +49 (0)7664/5909-0  
Fax. +49 (0)7664/5909-99

[www.knf.com](http://www.knf.com)

## Index

1	About this document .....	3
1.1	Using the operating and installation instructions.....	3
1.2	Exclusion of liability.....	3
1.3	Symbols and markings.....	4
2	Use.....	6
2.1	Proper use .....	6
2.2	Improper use .....	6
2.3	Use in potentially explosive areas.....	7
2.4	Explanations of the explosion protection designation .....	7
3	Safety .....	12
4	Technical data.....	14
4.1	Technical data N87TT.9E EX .....	14
5	Product description .....	15
6	Transport.....	17
	General .....	17
7	Installation and connection.....	18
7.1	Installing the pump.....	18
7.2	Electrical connection .....	20
7.3	Pneumatic connection.....	20
8	Operation .....	22
8.1	General .....	22
8.2	Information on switching the pump on and off .....	24
9	Servicing .....	25
9.1	Servicing schedule.....	25
9.2	Cleaning.....	27
9.3	Replacing the structured diaphragm and valve plates/ seals (TT design) .....	27
9.4	Changing the structured diaphragm and valve plates/ seals (S_-/A_ design based on project) .....	30
10	Troubleshooting .....	34
11	Spare parts and accessories.....	37
11.1	Spare parts .....	37
11.2	Accessories.....	37
12	Returns.....	38
13	Appendix .....	39
13.1	Declaration of Conformity .....	39
13.2	Motor.....	43

# 1 About this document

## 1.1 Using the operating and installation instructions

The operating and installation instructions are part of the pump.

- In the event of uncertainties with regard to the content of the operating and installation instructions, please contact the manufacturer (contact data: see [www.knf.com](http://www.knf.com)). Please have the type and serial number of the pump ready.
- Read the operating and installation instructions before you commission the pump.
- Give the operating and installation instructions only completely and unchanged to the next owner.
- Keep the operating and installation instructions within reach at all times.

**Project pumps** For customer-specific project pumps (pump models that begin with "PJ" or "PM"), there may be deviations from these operating and installation instructions.

- For project pumps, also observe the agreed specifications.
- The deviations are listed in the accompanying specifications sheet (CPD).

**Optional content** The operating and installation instructions may contain project-specific options. These are marked as "optional". It is also possible that project-specific deviations may not be contained in the operating and installation instructions.

**Motor** The operating and installation instructions apply for the pump part.

- Also observe the operating instructions for the motor in the appendix.

## 1.2 Exclusion of liability

The manufacturer assumes no liability for damages and malfunctions resulting from failure to observe the operating and installation instructions.

The manufacturer assumes no liability for damages and malfunctions resulting from changes or modifications to the device and improper handling.

The manufacturer assumes no liability for damages and malfunctions resulting from impermissible spare parts and accessories.

### 1.3 Symbols and markings

#### Warning notice



A notice that warns you of danger is located here. Possible consequences of a failure to observe the warning notice are specified here. The signal word, e.g., Warning, indicates the danger level.

→ Measures for avoiding the danger and its consequences are specified here.

#### Danger levels

Signal word	Meaning	Consequences if not observed
DANGER	warns of immediate danger	Death or serious injury or serious damage will result.
WARNING	warns of possible danger	Death, serious injury or serious damage is possible.
CAUTION	warns of a possibly dangerous situation	Minor injury or damage is possible.
NOTICE	Warns of possible damage	Damage is possible.

Tab.1 Danger levels









#### Other notices and symbols

→ An activity to be carried out is specified here (a step).

1. The first step of an activity to be carried out is specified here. Other sequentially numbered steps follow.

**i** This symbol indicates important information.

## Explanation of pictograms

Pictogram	Meaning
	General warning symbol
	Warning of hot surface
	Warning of electrical voltage
	Warning of explosive atmosphere
	Warning of poisonous substances
	Warning of hand injuries through crushing
	Observe the operating instructions
	General mandatory sign
	WEEE Symbol for separate tracking of electrical and electronic devices. The use of this symbol means that this product must be disposed of with normal household waste.

Tab.2 Explanation of pictograms

## 2 Use

### 2.1 Proper use

The pumps are intended exclusively for transferring gases and vapors.

#### Responsibility of the owner

Operating parameters and conditions Only install and operate the pumps in accordance with the operating parameters and conditions described in Chapter 4 *Technical data* and Chapter 2.3 *Use in potentially explosive areas*.

**i** Pumps with ATEX designation do not always satisfy the regulations for potentially explosive atmospheres in countries outside of the EU.

Only pumps that are fully assembled and in the condition as delivered may be operated.

Make sure that the installation location is dry and that the pump is protected against rain, splash, gushing, and drip water as well as from other contaminants.

The pump is suitable for transferring potentially explosive atmospheres and for operation in potentially explosive atmospheres.

Check the tightness of the connections between the pipes of the application and the pump (or the connection of the pump) at regular intervals. Leaky connections carry the risk of releasing dangerous gases and vapors from the pump system.

Requirements on the transferred medium Before transferring a medium, check whether the medium can be transferred danger-free in the specific application.

Before using a medium, check the compatibility of the media-contacting components (see 4 *Technical data*) with the medium.

Risk of dangerous gas mixtures during pump operation if diaphragm breaks: Depending on the medium being transferred, breakage of the diaphragm can result in a dangerous mixture if the medium mixes with the air in the compressor housing or the surroundings.

Make certain that no risk of explosion arises even in extreme operating situations (temperature, pressure) and in the event of system breakdowns.

Only transfer gases that remain stable under the pressures and temperatures that arise in the pump.

### 2.2 Improper use

The pumps are not suitable for use below ground.

The pumps are not suitable for delivering:

- Dusts
- Fluids
- Aerosols
- Biological and microbiological substances
- Explosives
- Fibers
- Foodstuffs.

Pumps that can produce both vacuum as well as overpressure may not be used to simultaneously produce vacuum and overpressure.

This function can be made possible on a project basis following consultation with KNF Customer Service.



No overpressure may be applied to the suction side of the pump.

This function can be made possible on a project basis following consultation with KNF Customer Service.

## 2.3 Use in potentially explosive areas

In potentially explosive atmospheres (zones), only operate pumps and motors of the appropriate category and temperature class.

The pumps have the following EU explosion protection designation:

Designation	Description
	Symbol for explosion-proof pumps
II	Equipment group (see Chapter 2.4.1 <i>Device groups</i> )
2/2G	Device category (see Chapter 2.4.2 <i>Device categories for gas</i> )
Ex	Symbol indicates that the device complies with one or more types of protection
h	Symbol for type of protection (see Chapter 2.4.5 <i>Ignition protection type</i> )
IIB + H2	Explosion groups (see Chapter 2.4.3 <i>Explosion groups</i> )
T3	N87TT.9E Temperature class (see Chapter 2.4.4 <i>Temperature classes</i> )
T4	N87TT.9E 5L Temperature class (see Chapter 2.4.4 <i>Temperature classes</i> )
Gb	Equipment protection level (See Chapter 2.4.6 <i>Equipment protection level for gas</i> )
	Special operating conditions (See Chapter 2.4.7 <i>Special operating conditions</i> )

Tab.3

An ignition hazard evaluation according to the standards DIN EN ISO 80079-36 and DIN EN ISO 80079-37 was carried out for the devices. The protective goals were reached by applying the ignition protection type of constructional safety "c".

The explosion protection designation can also be found at the following location:

- Type plate of the pump

Motor The pump motor must have at least the same explosion protection as the pump.

## 2.4 Explanations of the explosion protection designation

### 2.4.1 Device groups

Device group I Device group I applies for devices that are used in underground plants of mines as well as their underground systems that could be endangered by methane and/or combustible dusts.

Device group II Device group II applies for devices that are used in other areas that could be endangered by an explosive atmosphere.

### 2.4.2 Device categories for gas

The device category describes the frequency and the duration of the occurrence of explosive atmospheres during operation.

Device category	Description
1G	Devices of this category are designed for use in areas in which an explosive atmosphere consisting of a mixture of air and gases, vapors or mists is present constantly or for long periods of time or often.
1D	Devices of this category are designed for use in areas in which an explosive atmosphere consisting of a dust/air mixture is present constantly or for long periods of time or often.
2G	Devices of this category are designed for use in areas in which it is to be expected that an explosive atmosphere consisting of gases, vapors or mists forms occasionally.
2/2G	Devices that extract from zone 1 and are designed for use in areas in which it is to be expected that an explosive atmosphere consisting of gases, vapors or mists forms occasionally.
2/-G	Devices that extract from zone 1 but are not designed for installation in a potentially explosive atmosphere (zone).
2D	Devices of this category are designed for use in areas in which it is to be expected that an explosive atmosphere consisting of a dust/air mixture forms occasionally.
3G	Devices of this category are designed for uses in areas in which it is to be expected that an explosive atmosphere resulting from gases, vapors or mists occurs, though in all likelihood occurs only seldom and for a very short length of time.
3/-G	Devices that extract from zone 2 but are not designed for installation in a potentially explosive atmosphere (zone).
3D	Devices of this category are designed for uses in areas in which it is to be expected that an explosive atmosphere resulting from stirred-up dust occurs, though in all likelihood occurs only seldom and for a very short length of time.

Tab.4



### 2.4.3 Explosion groups

Combustible gases and vapors are classified according to explosion groups (I, IIA, IIB and IIC) and temperature classes. The following table shows the classification of the most common combustible gases and vapors.

	T1	T2	T3	T4	T5	T6
I	Methane	–	–	–	–	–
IIA	Acetone Ethane Ethyl acetate Ammonia Ethyl chloride Benzene Acetic acid Carbon monoxide Methane Methanol Methyl chloride Naphthalene Phenol Propane Toluene	i-amyl acetate n-butane n-butyl alcohol Cyclohexanone 1,2-dichloroethane Acetic anhydride	Gasoline Diesel fuel Jet fuel Heating oils n-hexane	Acetaldehyde	–	–
IIB	Town gas	Ethylene Ethyl alcohol	Hydrogen sulfide	Ethyl ether	–	–
IIC	Hydrogen	Acetylene	–	–	–	Carbon disulfide

Tab.5

The classification of gases and vapors into groups with respect to explosion group and temperature class applies for the transferred medium as well as for the pump surroundings.

**Transferred medium** The device must only be used to transfer gases and vapors that belong to the respective explosion group and the corresponding temperature class (or lower), (see designation on the type plate) or which are not explosive and not combustible.

**Surroundings of the device** The devices may only be operated in an environment with an atmosphere that belongs to the respective explosion group and the corresponding temperature class (or below) (see designation on the type plate) or which is not explosive and not combustible.

#### 2.4.4 Temperature classes

- Maximum surface temperature The maximum surface temperature is the highest temperature reached by a surface of the device under the most unfavorable conditions.
- Ignition temperature The maximum surface temperature of the device must always be lower than the lowest ignition temperature of the gas/air or vapor/air mixture in which it is used.
- Temperature class The maximum surface temperature is derived from the construction of the device and is stated as the temperature class.

Temperature class	Max. surface temperature [°C]	Ignition temperature [°C]
T1	450	> 450
T2	300	> 300
T3	200	> 200
T4	135	> 135
T5	100	> 100
T6	85	> 85

Tab.6

The temperature class of the pump was determined using air. If gas mixtures consisting mainly of gases with a greater isentropic exponent than that of air (helium, argon, xenon, neon, krypton) are pumped, compressing these mixtures can give rise to higher gas temperatures, and consequently higher surface temperatures as well. This must be taken into account and if necessary tested before operating the pump. When gas mixtures of this kind are pumped, it is recommended to run the pump with water cooling connected.

#### 2.4.5 Ignition protection type

Designation	Description
h	Constructional safety "c"
h	Ignition source monitoring "b"
h	Liquid immersion "k"

Tab.7

An ignition hazard evaluation according to the standards DIN EN ISO 80079-36 and DIN EN ISO 80079-37 was carried out for the devices. The protective goals were reached by applying the ignition protection type of constructional safety "c".

### 2.4.6 Equipment protection level for gas

The equipment protection level describes the frequency and the duration of the occurrence of explosive atmospheres in an area.

Equipment protection level	Description*	Constructional safety
Ga	Devices with very high protection level for use in potentially explosive atmospheres. With these devices, there is no risk of ignition during normal operation or in the event of foreseeable or infrequent faults/malfunctions.	Very high
Gb	Devices with high protection level for use in potentially explosive atmospheres in which there is no risk of ignition during normal operation or in the event of foreseeable or infrequent faults/malfunctions.	High
Gc	Device with increased protection level for use in potentially explosive atmospheres. There is no risk of ignition during normal operation. The devices have a number of additional protection measures which ensure that, in the event of commonly foreseeable faults in the device, no danger of ignition exists.	Increased

Tab.8 \*According to ISO 80079-36

### 2.4.7 Special operating conditions

- The devices must not be installed outdoors. Commissioning may only be performed with suitable weather- and corrosion-protection paneling.
- The devices must be installed in a way that ensures they are not exposed to UV radiation.

### 3 Safety

**i** Observe the safety notices in Chapters 7 *Installation and connection* and 8 *Operation*.

The pumps are produced in accordance with the generally recognized rules of engineering, as well as the occupational health, safety and accident prevention regulations. Nevertheless, dangers can arise during their use that lead to injuries to the user or third parties or to damage to the pump or other property.

Only use the pumps in perfect technical condition, for their intended purpose, safely and aware of the dangers and in observation of the operating instructions.

The components that are to be connected to the pumps must be designed according to the pneumatic data of the pumps.

When connecting the pumps to the electrical mains, observe the corresponding safety rules.

**Personnel** Make sure that only specialized personnel work on the pumps. This applies in particular for connection and maintenance work.

Make sure that the personnel have read and understood the operating instructions, particularly the chapter on safety.

**Working in a safety conscious manner** Observe the regulations on accident prevention and safety during all work on the pumps and during operation.

Avoid contact with the heads and housing parts, as the pump heats up during operation.

When working on the pump, make certain that the pump is disconnected from mains and without power.

Ensure that no hazards arise from gas flowing when gas connections are open, from the effects of noise or from hot, corrosive, dangerous and environmentally hazardous gases.

**Classification of a pump environment** When classifying a pump environment in a potentially explosive area (zone), observe the "Guideline for Preventing Danger from Explosive Atmospheres, with a Collection of Examples – Explosion Protection Guidelines – (EX-RL)".

If the situation relates to special cases or if doubt exists about the definition of the potentially explosive atmospheres, inform the regulatory authorities and have them make the decision.

**Use in a potentially explosive environment** The following applies for use in a potentially explosive environment consisting of gases, vapors and mists:

The lowest ignition temperature of the potentially explosive atmospheres that comes into question must be higher than the "maximum surface temperature" of the pump.

According to DIN EN ISO 80079-36, the maximum surface temperature is the highest temperature that is achieved during operation under the most unfavorable conditions (but within the accepted tolerances) of a part or on a surface of the pump.

The maximum surface temperature is specified from the design of the pump and noted on the pump type plate as the temperature class.

**Explosion protection** The introduction of ignition sources such as sparks, open flames and hot surfaces may result in explosions in potentially explosive atmospheres.

Therefore, during transport, during installation and during all work on the device in the potentially explosive atmosphere:

- Only perform work when there is no possibility of a potentially explosive atmosphere.

- Handling of hazardous media

  - Only use tools and lifting gear that are approved for use in potentially explosive atmospheres.

Upon breakage of the diaphragm and/or leaks, the transferred medium mixes with the air in the surroundings and/or in the pump housing. Make sure that a dangerous situation cannot arise as a result.

When pumping hazardous media, follow the safety regulations that govern working with these media.
- Handling of combustible media

Make certain that the temperature of the medium is always sufficiently below the ignition temperature of the medium so as to prevent ignition or explosion. This also applies for abnormal operating situations.

At the same time, note that the temperature of the medium rises as the pump compresses the medium.

Therefore, make certain that the temperature of the medium also remains sufficiently below the ignition temperature of the medium even when it is compressed to the maximum permissible operating pressure of the pump. The maximum permissible operating pressure of the pump is stated in Chapter 4 *Technical data*.

Make certain that the permissible ambient temperature (4 *Technical data*) is not exceeded.

Where applicable, also take into account external energy sources (such as radiated heat sources) that might heat the medium further.

In case of doubt, contact KNF Customer Service.
- Environmental protection

Store all spare parts so that they are protected according to environmental protection regulations. Observe the national and international regulations. This applies in particular to parts that are contaminated with toxic substances.

 This product is marked in conformance with the EU directive on the disposal of Waste Electrical and Electronic Equipment (WEEE). Old devices must not be disposed of with household waste.

Proper disposal and recycling help to protect natural resources and the environment. The end user is responsible for disposing of old devices according to the national and international regulations. Alternatively, KNF products (old devices) may also be returned to KNF for a fee (see Chapter 12 *Returns*).
- EU/EC directives/standards

See EC/EU Declaration of Conformity

- Customer service and repairs

The pumps are maintenance-free. However, KNF recommends periodic inspections to check the pump for obvious changes in noise and vibration.

Only have repairs to the pumps performed by the responsible KNF Customer Service department.

Housings with electrically live components may only be opened by specialized personnel.

Use only genuine spare parts from KNF when performing servicing work.

Only have repairs to the motors performed by the responsible KNF Customer Service.

## 4 Technical data

### 4.1 Technical data N87TT.9E EX

#### Pump materials

Assembly	Material
Pump head	PVDF
Diaphragm	PTFE-coated
Valve plate/seal	FFPM

Tab.9

#### Pneumatic values

Parameter	Value N87TT.9E	Value N87TT.9E 5L
Max. permissible operating pressure [bar rel*]	1.5	1.0
Ultimate vacuum [mbar abs.]	140	170
Flow rate at atm. pressure [l/min]**	7.5	5.0

Tab.10 \*bar rel relative to 1013 hPa

\*\*Liters in the standard state based on ISO 8778 and ISO 21360-1/2 (1013 hPa, 20°C)

#### Pneumatic connections

Pump type	Value
N87TT.9E EX	Thread size G1/8*

Tab.11 \*Acc. to ISO 228

#### Other parameters

Parameter	Value N87TT.9E	Value N87TT.9E 5L
Permissible ambient temperature [°C]	+ 5 to + 50	+ 5 to + 40
Permissible media temperature [°C]	+ 5 to + 50	+ 5 to + 40
Dimensions	See Fig. 3, Chapter 7.1 <i>Installing the pump</i>	
Electrical data	See motor type plate	
Gas tightness* of the pump head	< 6 x 10 <sup>-3</sup> mbar l/s	
Relative air humidity	80% for temperatures to 31 °C, decreasing linearly to 50% at 40 °C (non-condensing).	

Tab.12 \*The gas tightness of the pump head is no longer ensured after the pump head is opened or after replacing diaphragm and valve plates/seals. A leak test can be used to determine whether the original gas tightness has been re-established.

#### Weight

Pump type	Value [kg]
N87TT.9E EX	6.65

Tab.13

## 5 Product description

Design

- 1 Pump outlet
- 2 Pump inlet
- 3 Pump head
- 4 Drive type plate
- 5 drive
- 6 Pump type plate

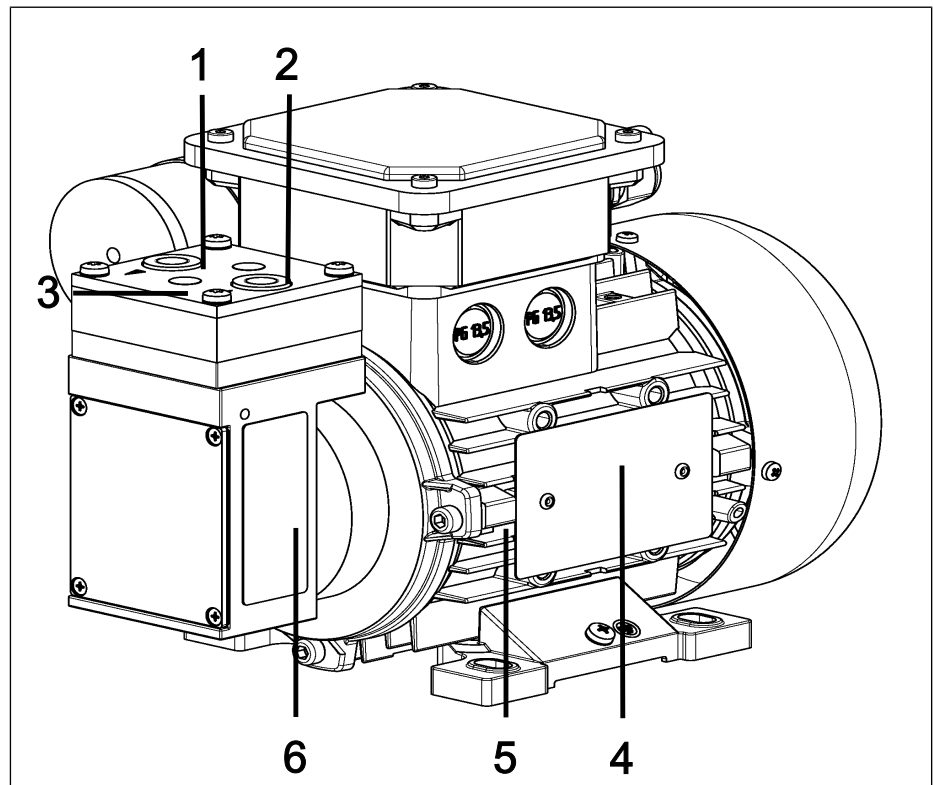
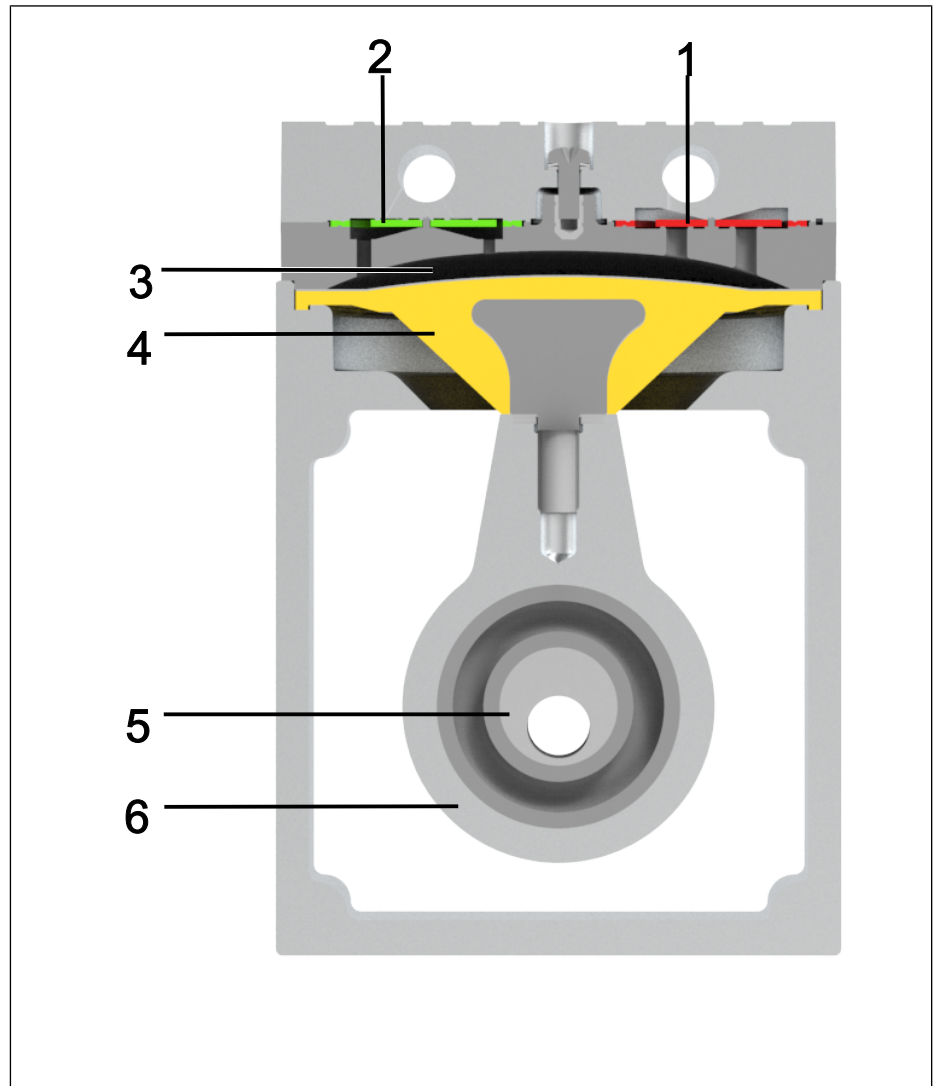

Fig.1 Design N87TT.9E EX

**Function of a diaphragm pump**

- 1 Outlet valve
- 2 Inlet valve
- 3 Transfer chamber
- 4 Diaphragm
- 5 Eccentric
- 6 Connecting rod



*Fig.2 Function of a diaphragm pump*

Diaphragm pumps transfer, compress (depending on the version) and evacuate gases and vapors.

The elastic diaphragm (4) is moved up and down by the eccentric (5) and the connecting rod (6). In the downwards stroke, it aspirates the gas to be transferred via the inlet valve (2). In the upwards stroke, the diaphragm presses the medium out of the pump head via the outlet valve (1). The transfer chamber (3) is separated from the pump drive by the diaphragm.



## 6 Transport

### General



Personal injury and/or property damage due to incorrect or improper transport of the pump

In the event of incorrect or improper transport, the pump can fall down, be damaged or injure persons.

- Use suitable auxiliary means if necessary (carrying strap, lifting gear, etc.).
- Where appropriate, wear suitable personal protective equipment (e.g., safety shoes, safety gloves).



Risk of injury from sharp edges on the packaging

There is a risk of injury from cutting on the sharp edges when grabbing corners or when opening the packaging.

- Where appropriate, wear suitable personal protective equipment (e.g., safety shoes, safety gloves).

- Transport the pump in the original packaging to the installation location.
- Keep the original packaging of the pump (e.g. for later storage).
- Inspect the pump for transport damage after receiving it.
- Document any transport damage.
- Remove any transport safeguards on the pump prior to commissioning.

### Parameter

Parameter	Value
Storage temperature [°C]	+ 5 to + 40
Transport temperature [°C]	- 10 to + 60
Permissible humidity (non-condensing) [%]	30 to 85

Tab.14 Transport parameters and storage parameters



Prior to commissioning, make sure that the pump has reached the ambient temperature (4 Technical data).

## 7 Installation and connection

The pumps are only to be installed in accordance with the operating parameters and conditions described in Chapter 4 *Technical data*.

→ Observe the safety notices (see Chapter Safety).



Risk of dangerous gas mixtures during pump operation

Depending on the medium being transferred, breakage of the media-contacting components can result in a dangerous mixture if the medium mixes with the air in the compressor housing or the surroundings.

→ Before using a medium, check the compatibility of the media-contacting components (see 4 *Technical data*) with the medium.

### 7.1 Installing the pump

→ Store the pump at the installation site prior to installation to bring it up to the ambient temperature.

Mounting dimensions → For mounting dimensions, see following figures:

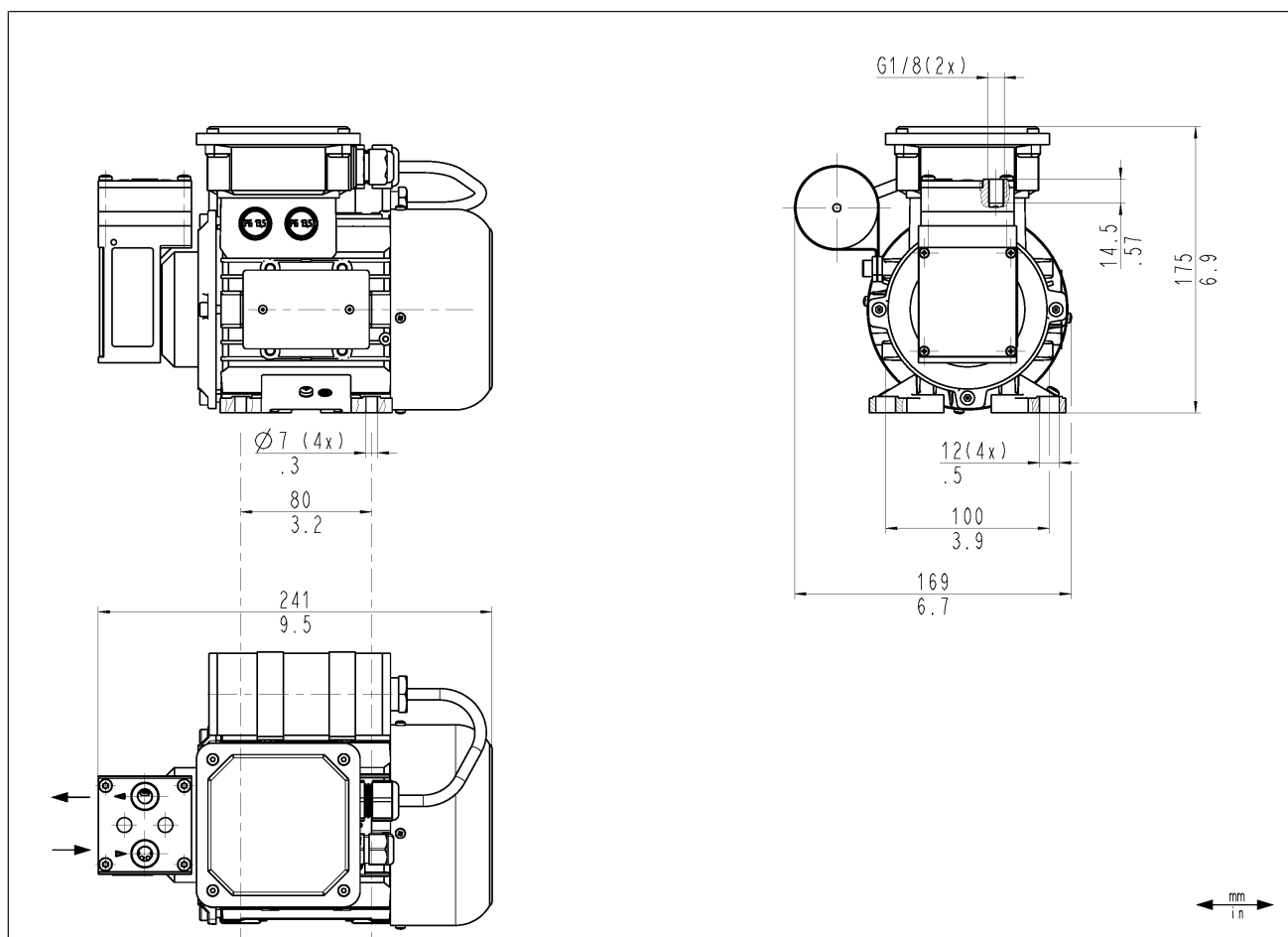





Fig.3 Fastening dimensions N87TT.9E EX

Cooling air supply	 <p><b>EX</b> <b>WARNING</b></p>	<p>Risk of explosion due to lack of cooling air supply</p> <ul style="list-style-type: none"> <li>→ Mount the pump so that the fan wheel of the pump can draw in sufficient cooling air.</li> <li>→ Ensure sufficient ventilation or heat dissipation in the vicinity of the pump.</li> </ul>
Immediate environment of the hot pump parts	 <p><b>WARNING</b></p>	<p>Danger of burning on hot surfaces Hot surfaces could occur if the pump overheats.</p> <ul style="list-style-type: none"> <li>→ When installing the pump, make sure that sufficient cooling air infeed and discharge is ensured.</li> </ul>
Installation location		<ul style="list-style-type: none"> <li>→ During installation, make sure that no combustible or thermally deformable objects are positioned in the immediate proximity of the hot pump parts (head, drive).</li> <li>→ Make sure that the installation location is dry and that the pump is protected from rain, spray water, splash water, dripping water and other contaminants.</li> <li>→ Make sure that the installation location is accessible for service.</li> <li>→ Make sure that access to moving parts is prevented.</li> <li><b>i</b> The IP protection class of the pump motor is specified on the type plate.</li> <li>→ Mount the pump at the highest point in the system to prevent condensate from collecting in the pump head.</li> <li>→ Protect the pump from dust.</li> <li>→ Protect the pump from vibration and impact.</li> </ul>
Installation position	 <p><b>WARNING</b></p>	<p>Personal injury and/or property damage from vibrations Pump vibrations, in combination with adjacent components, can result in crushing and/or damage to these components.</p> <ul style="list-style-type: none"> <li>→ Make sure that pump vibrations cannot lead to dangers in combination with adjacent components.</li> </ul>
		<ul style="list-style-type: none"> <li>→ The pump must be installed in the depicted installation position. Use metal screws to fasten the pump at the attachment points indicated in Chapter 7 <i>Installation and connection</i>.</li> </ul>

### 7.2 Electrical connection



Danger to life from electric shock

- Only have the pump connected by an authorized specialist.
- Only have the pump connected if the power supply is disconnected.



Risk of explosion from electrostatic charge

- Connect the pump so that the risk of ignition from electrostatic charge is avoided.
- Carefully ground the pump.

- When connecting to a power source, observe the applicable regulations, directives, and technical standards.
- When connecting to a power source, carefully read and observe the operating instructions for the motor.
- Install a device for separating the pump motor from the electrical mains in the electrical installation.
- Install an Emergency Off device such that it is not possible for there to be an automatic restart or for hazardous situations to persons and property to occur.

Potentially explosive atmospheres

- Only place the electrical equipment that is necessary for the operation of the pump .

- Take lightning protection measures.

Fastening the connection cables

- Fasten the connection cables so that
  - the cables do not come into contact with movable or hot parts.
  - the cables cannot be worn or damaged on sharp corners or edges
  - no tensile and pressure forces are exerted on the connection point of the cables (strain relief)

### 7.3 Pneumatic connection



Personal injury or property damage through ejected plugs

If not removed, the plugs on the pressure side of the pump can be ejected during operation by the resulting overpressure.

- Remove the plugs during installation.
- Wear appropriate personal protective equipment.

Connected components

- Only connect components to the pump that are designed for the pneumatic data and thermal requirements of the pump. (see Chapter 4 *Technical data*).

- Pressure relief device → Protect the compressors by means of a pressure relief device between the pressure-side connections of the compressor and the first shut-off valve.



Risk of explosion during pressure limitation resulting from the medium mixing with the environment

- Make certain that there is no risk of explosion posed by the medium mixing with the environment.

- Pump discharge → If the pump is used as a vacuum pump, safely (with respect to medium and noise) drain the hot pump discharge that may, under certain circumstances, occur at the pneumatic outlet of the pump.

- Decoupling → KNF recommends mechanically decoupling the pump from the pipe system, e.g., through the use of flexible hoses or pipes. In this way it is possible to prevent the transfer of possible pump vibrations and noises to the system.

### Connecting the pump



Risk of injury from mixing up suction side and pressure side

Mixing up the suction side and pressure side can result in breakage of connected components on the suction side and pressure side.

- Observe the marking of inlet and outlet on the pump head.

1. Remove the protective plugs from the gas connection threads.
2. Connect the suction line and the pressure line (for mounting dimensions, see Chapter 4 *Technical data*).
3. Lay the suction line and the pressure line at a downward angle to prevent condensate from running into the pump.

## 8 Operation

### 8.1 General

---



Risk of burns from hot pump parts and/or hot medium

Some pump parts may be hot during or after operation of the pump.

- Allow the pump to cool after operation.
  - Take protective measures to protect against touching hot parts.
- 



Damage to the pump due to overheating

If gases with a greater isentropic exponent than that of air (helium, argon, xenon, neon, krypton) are pumped, compressing these gases gives rise to higher gas temperatures. The higher temperatures may impair the functional capabilities of the parts of the pump that are in contact with the media and possibly also adjacent components (e.g., ball bearings). This in turn will shorten the service life of the pump.

- If necessary, contact KNF Customer Service.
- 



Risk of explosion due to excessively high surface temperature

The temperature class of the pump was determined using air. If gas mixtures consisting mainly of gases with a greater isentropic exponent than that of air (helium, argon, xenon, neon, krypton) are pumped, compressing these mixtures can give rise to higher gas temperatures, and consequently higher surface temperatures as well.

- Before pumping gas mixtures of this kind, check the surface temperature before running the pump.
  - When pumping gas mixtures of this kind, run the pump with water cooling connected.
- 



Injury to eyes

Coming too close to the inlet/outlet of the pump may result in injury to the eyes due to the present vacuum/operating pressure.

- Do not look into the pump inlet/outlet during operation.
-

- Only operate the pumps in accordance with the operating parameters and operating conditions described in Chapter 4 *Technical data* and in Chapter 2.3 *Use in potentially explosive areas*.
- Ensure the proper use of the pumps (See Chapter 2.1 *Proper use*).
- Eliminate the possibility of improper use of the pumps (see Chapter 2.2 *Improper use*).
- Observe safety notices (Chapter 3 *Safety*).



Risk of pump head bursting due to excessive pressure increase

- Do not exceed the maximum permissible operating pressure (see 4 *Technical data*).
- Monitor the pressure during operation.
- If the pressure exceeds the maximum permissible operating pressure of the pump: immediately switch off the pump and remedy the fault (see Chapter *Troubleshooting*).
- Only throttle or regulate the air or gas quantity on the suction line to prevent the maximum permissible operating pressure from being exceeded.
- If the air quantity or gas quantity on the pressure line is throttled or regulated, make sure that the maximum permissible operating pressure at the pump is not exceeded.
- Ensure that the pump outlet is not closed or restricted.



Risk of explosion from elevated ambient temperature

- Monitor the ambient temperature (compression heat, motor heat).
- Ensure sufficient cooling air supply.



Risk of dangerous gas mixtures during pump operation if diaphragm breaks

If the diaphragm should break, the medium will mix with the air in the compressor housing or in the surroundings.

- Stop pump immediately.
- Replace the diaphragm prior to further operation (see Chapter 9 *Servicing*).

- i** Because the diaphragm is a wear part, diaphragm breakage may occur at any time.
- Pump standstill → When the pump is at a standstill, establish normal atmospheric pressure in the lines.
- Vapors as medium → The service life of the diaphragm can be prolonged if condensation does not form in the pump. Therefore, only carry out work with saturated or near-saturated vapors while the pump is warm.
- i** Operation with open suction-side gas connection can result in contaminants and objects being drawn in.

## 8.2 Information on switching the pump on and off

### Switching on the pump

- i** The pump must not be started up against pressure or vacuum during switch-on. This also applies during operation after a brief power failure.
- Ensure that there is normal atmospheric pressure in the lines when switching on.

### Switching off the pump

- KNF recommends: When pumping corrosive media, flush the pump before switching off (see Chapter 9.2.1 *Flushing the pump*) to extend the service life of the diaphragm.
- Establish normal atmospheric pressure in the lines (relieve pump pneumatically).
- Recommissioning → Before recommissioning, observe the applicable standards, guidelines, regulations and technical standards at the electrical connection.
- Inspecting the pump → Inspect the pump periodically for external damage or leakage.



---

## 9 Servicing

---



### NOTICE

Servicing the pump

Damage to the pumps can result from failure to observe the applicable legal regulations and procedures for the location or intervention by untrained or uninstructed personnel.

- Servicing may only be performed according to the legal regulations (e.g. work safety, environmental protection) and provisions.
  - Servicing may only be performed by specialized personnel or trained and instructed personnel.
- 

### 9.1 Servicing schedule

---



### WARNING

Risk of explosion from wear

- Have the connecting rod bearing replaced by KNF according to servicing schedule.
  - Have the motor bearing replaced by KNF according to servicing schedule.
- 



### WARNING

Risk of explosion if genuine spare parts are not used

If genuine spare parts are not used, the pump loses its explosion protection properties. Furthermore, the function of the pump and its safety are lost.

The validity of the conformity is rendered void if genuine spare parts are not used.

- Use only genuine spare parts from KNF when performing maintenance work.
-

Component	Servicing interval
Pump	<ul style="list-style-type: none"> <li>→ Perform periodic inspections for external damage or leakage.</li> <li>→ Periodically check for noticeable changes to noises and vibrations.</li> </ul>
Diaphragm and valve plates/seals	→ At the latest, replace when the pump flow rate decreases
Connection rod bearing	→ Replace after 34,000 operating hours or after no more than 48 months
Motor bearing	→ Replace after 34,000 operating hours or after no more than 48 months
Gas connections	→ Inspect the pump periodically for external damage or leakage

Tab.15

The ball bearings installed in the pump and in the drive motor are lubricated for life. This means that the bearings are coated with a high-quality grease with a high degree of purity and an ideal fill level by the bearing manufacturer at the plant. These bearings cannot be relubricated. The prescribed bearing replacement periods can be found in Chapter 9.1 *Servicing schedule*.

The duration of use of the bearing grease depends on many highly individual factors. The prescribed bearing replacement periods were specified under the assumption of normal ambient conditions. Factors that can make early bearing replacement necessary include dust or dirt that may get into the bearing, aggressive gases or vapors that may change the lubricating properties of the bearing grease, etc. It is the operator's responsibility to assess these factors.

## 9.2 Cleaning

### 9.2.1 Flushing the pump



Risk of explosion by flushing the pump with air

- In potentially explosive areas or when using the pump with explosive media, only permit specialist to flush the pump with inert gas.



Risk of burns from hot pump parts and/or hot medium

Some pump parts may be hot during or after operation of the pump.

- Allow the pump to cool after operation.
- Take protective measures to protect against touching hot parts.

- Before switching off the pump under atmospheric conditions, flush for several minutes with inert gas.

**i** If there is no risk of explosion, flushing can also be performed with air.

- Discharge the media safely.

### 9.2.2 Cleaning the pump



Risk of explosion from electrostatic charging of the components

- Only clean the pump with a damp cloth.

- Only clean the pump with a damp cloth and non-flammable cleaning agents.

- Only use solvents during cleaning if head materials are not corroded (ensure resistance of the material).

- If compressed air is present, blow out the components.

## 9.3 Replacing the structured diaphragm and valve plates/seals (TT design)

- Requirements
- Disconnect the motor from the mains and ensure that it is voltage-free.
  - Clean the pump and remove any hazardous materials.

Spare parts	Spare part*	Item designation**	Number per pump head
	Structured diaphragm	(7) in Fig. 5	1
	Valve plates/seals	(12) in Fig. 5	2

Tab.16 \*According to spare parts list, Chapter 11.1 Spare parts

Tools and material

Quantity	Tool/material
1	TORX® screwdriver T10
1	TORX® screwdriver T20
1	Phillips screwdriver
	Thread locker (Loctite 222 or comparable product)
1	Felt-tip pen

Tab.17

Information on the procedure → Always replace diaphragm and valve plate/seals together to maintain the performance of the pump.



Risk of explosion from formation of potentially explosive atmosphere

Leaky connections can result in dangerous potentially explosive atmospheres.

- Make certain that all elastomer parts are undamaged, clean and correctly installed.
- Check the pneumatic connections of the pump for leaks.
- Work with care during service work.
- Replace defective parts immediately.



Health hazard due to dangerous substances in the pump

Depending on the medium being transferred, caustic burns or poisoning is possible.

- Wear protective equipment if necessary, e.g., protective gloves, goggles.
- Clean the pump with suitable measures.

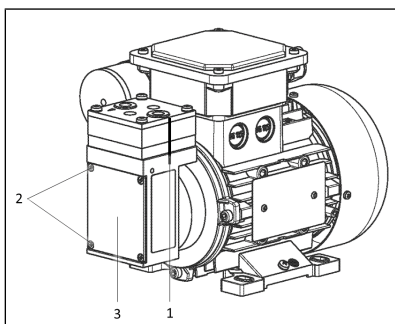

Fig.4 Marking with felt-tip pen

**Removing the pump head**

1. Mark the pressure plate, head plate, intermediate plate and housing with a felt-tip pen ( Fig. 4/1) to ensure proper mounting.
2. Remove the housing cover ( Fig. 4/3).



Risk of explosion from damage

If the housing cover is bent or if the paint is damaged, there is no risk of explosion.

- Perform the work steps carefully and without the use of force.

3. Loosen the four fastening screws ( Fig. 4/2) and remove the housing cover ( Fig. 4/3).

The counterweight is visible.

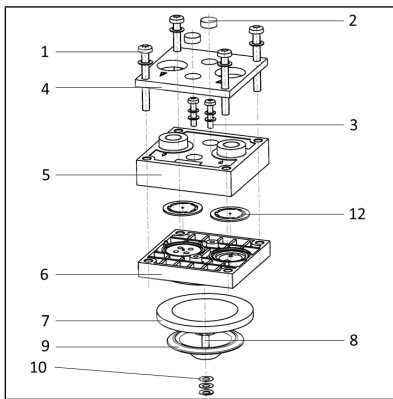

Fig.5 Replacing the structured diaphragm

4. Loosen the four screws ( Fig. 5/1) and remove the pressure plate ( Fig. 5/4).
5. Remove the screw covers ( Fig. 5/2); loosen the two screws ( Fig. 5/3) and remove the head plate ( Fig. 5/5) and the intermediate plate ( Fig. 5/6).

The structured diaphragm (7) is visible.

#### Replacing the structured diaphragm

1. Turn the pump to the side; this keeps the shims (10) from falling into the pump chamber when removing the structured diaphragm (7).
2. Move the structured diaphragm (7) by turning the counterweight to the upper reversal point.
3. Lift the structured diaphragm (7) onto opposing side edges; hold the structured diaphragm and unscrew it counterclockwise.
4. Remove the diaphragm support (9) and the shim(s) (10) from the threaded bolt (8) of the structured diaphragm and put them to one side.
5. Check all parts for contamination and clean them if necessary.
6. Push the diaphragm support (9) and shim(s) (10) onto the threaded bolt (8) of the new structured diaphragm (7) in this order.
7. Move the connecting rod (connection part between drive shaft and structured diaphragm) to the upper reversal point by turning the counterweight.
8. Screw the structured diaphragm with diaphragm support and shim(s) clockwise onto the connecting rod and tighten finger-tight.

#### Replacing the valve plates/seals

1. Remove the valve plates/seals (12) from the intermediate plate (6).
2. Check the valve seats, intermediate plate (6) and head plate (5) for soiling and damage. Clean the parts if necessary.
3. Contact KNF in the event of unevenness, scratches or corrosion. Order and replace damaged parts.
4. Insert the new valve plates/seals (12) in the valve seats of the intermediate plates (6).
5. Place the head plate (5) on the intermediate plate according to the felt-tip pen marking.
6. Check the centering of the head plate (5) by means of a slight lateral movement.
7. Connect head plate (5) and intermediate plate (6). To do this, screw in screws (3; Fig. 6: A + B) with disk spring (11) and shim rings (10) until the screw head is seated flat, i.e., until the first resistance is encountered. Apply a small amount of thread locker (Loctite 222 or comparable product) to the threads of the screws.

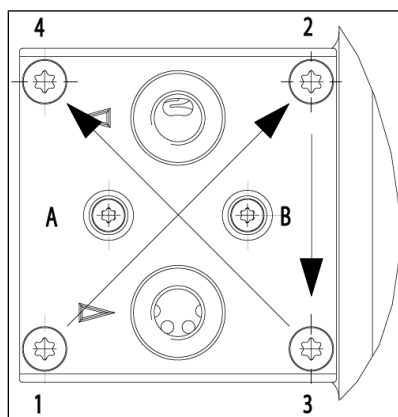

Fig.6 Tightening cap head screws

**Mounting the pump head**

1. Place the pump head on the housing according to the felt-tip pen marking.
2. Place the pressure plate (4) on the head plate according to the felt-tip pen marking.
3. Screw in the screws (1) with disk spring (11) and slightly tighten them crosswise in the order 1-2-3-4 (see Fig. 6) with 1 Nm.
4. Check for ease of movement of the pump by turning the counterweight.
5. Tighten the screws (1) with disk spring (11) crosswise in the order 1-2-3-4 (see Fig. 6). Tightening torque: 2.1 Nm.
6. Then tighten the screws (3; Fig. 6: A + B) another quarter turn (tightening torque: 30 Ncm) and mount the screw covers (2).

**Final steps**

1. Mount the housing cover.
2. Check the pump head and pneumatic connections for leaks.
3. Properly dispose of the replaced structured diaphragm and valve plates/seals.



**NOTICE**

To ensure the required gas tightness of the pump following servicing, a leak test is to be performed.



**WARNING**

Risk of explosion from leaks

- Before recommissioning the pump, check the pump heads and pneumatic connections for leaks. Leaks may lead to a risk of explosion.



**WARNING**

Risk of injury and poisoning from leaks

- Before recommissioning the pump, check the pump heads and pneumatic connections for leaks. Leaks may lead to poisoning, chemical burns or similar injuries.



Before recommissioning, observe the applicable standards, guidelines, regulations and technical standards at the electrical connection.

**9.4 Changing the structured diaphragm and valve plates/seals (S\_-/A\_ design based on project)**

- Requirements
- Disconnect the motor from the mains and ensure that it is voltage-free.
  - Clean the pump and remove any hazardous materials.

Spare parts	Spare part*	Item designation**	Number per pump head
	Structured diaphragm	(7) in Fig. 8	1
	Valve plates/seals	(12) in Fig. 8	2

Tab.18 \*According to spare parts list, Chapter 11.1 Spare parts

Tools and material	Quantity	Tool/material
	1	TORX® screwdriver T20
	1	Phillips screwdriver
		Thread locker (Loctite 222 or comparable product)
	1	Felt-tip pen

Tab.19

Information on the procedure → Always replace diaphragm and valve plate/seals together to maintain the performance of the pump.



Risk of explosion from formation of potentially explosive atmosphere

Leaky connections can result in dangerous potentially explosive atmospheres.

- Make certain that all elastomer parts are undamaged, clean and correctly installed.
- Check the pneumatic connections of the pump for leaks.
- Work with care during service work.
- Replace defective parts immediately.



Health hazard due to dangerous substances in the pump

Depending on the medium being transferred, caustic burns or poisoning is possible.

- Wear protective equipment if necessary, e.g., protective gloves, goggles.
- Clean the pump with suitable measures.

### Removing the pump head

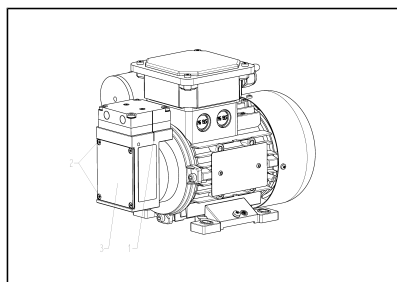

Fig.7 Marking with felt-tip pen

1. Mark the head plate, intermediate plate and housing with a felt-tip pen ( Fig. 7/1) to ensure proper mounting.
2. Remove the housing cover ( Fig. 7/3).



Risk of explosion from damage

If the housing cover is bent or if the paint is damaged, there is no risk of explosion.

- Perform the work steps carefully and without the use of force.

3. Loosen the four fastening screws ( Fig. 7/2) and remove the housing cover ( Fig. 7/3).

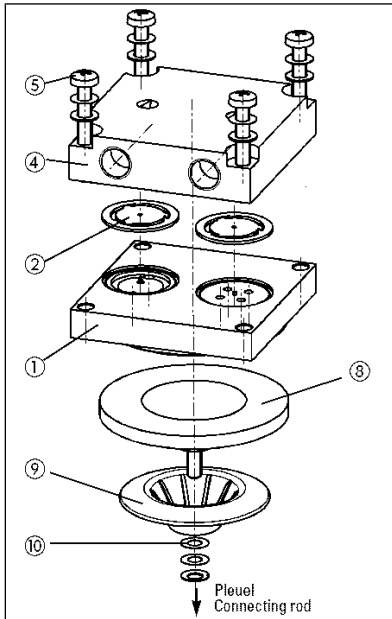

Fig.8 Replacing the structured diaphragm

The counterweight is visible.

4. Loosen the four screws ( Fig. 8/5).
5. Remove the head plate ( Fig. 8/4) and the intermediate plate ( Fig. 8/1).

The structured diaphragm (8) is visible.

#### Replacing the structured diaphragm

1. Turn the pump to the side; this keeps the shims (10) from falling into the pump chamber when removing the structured diaphragm (8).
2. Move the structured diaphragm (8) by turning the counterweight to the upper reversal point.
3. Lift the structured diaphragm (8) onto opposing side edges; hold the structured diaphragm and unscrew it counterclockwise.
4. Remove the diaphragm support (9) and the shim(s) (10) from the threaded bolt of the structured diaphragm (8) and put them to one side.
5. Check all parts for contamination and clean them if necessary.
6. Push the diaphragm support (9) and shim(s) (10) onto the threaded bolt of the new structured diaphragm (8) in this order.
7. Move the connecting rod (connection part between drive shaft and structured diaphragm) to the upper reversal point by turning the counterweight.
8. Screw the structured diaphragm with diaphragm support and shim(s) clockwise onto the connecting rod and tighten finger-tight.

#### Replacing the valve plates/seals

1. Separate the head plate (4) from the intermediate plate (1).
2. Remove the valve plates/seals (2) from the intermediate plate (1).
3. Check the valve seats, intermediate plate (1) and head plate (4) for soiling and damage. Clean the parts if necessary.
4. Contact KNF in the event of unevenness, scratches or corrosion. Order and replace damaged parts.

**i** The valve plates/seals are identical for the pressure and suction side. The same applies for the top and bottom of the valve plates/seals.

5. Insert the new valve plates/seals (2) in the valve seats of the intermediate plates (1).
6. Place the head plate (4) on the intermediate plate according to the felt-tip pen marking.
7. Check the centering of the head plate (4) by means of a slight lateral movement.



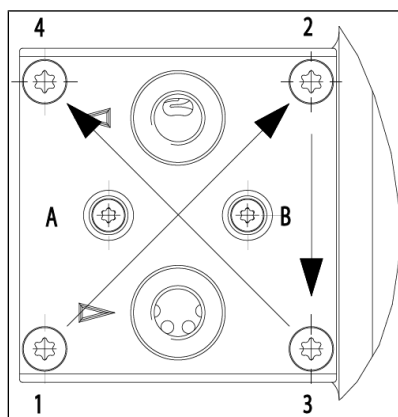

Fig.9 Tighten cap head screws  
(head plate shown as an example  
(screws (A) and (B) only in N87TTE  
design))

### Mounting the pump head

1. Place the pump head on the housing according to the felt-tip pen marking.
2. Screw in the screws (5) with disk spring and slightly tighten them crosswise in the order 1-2-3-4 (see Fig. 9) with 1 Nm.
3. Check for ease of movement of the pump by turning the counterweight.
4. Tighten the screws (5) with disk spring crosswise in the order 1-2-3-4 (see Fig. 9). Tightening torque: 2.1 Nm.

### Final steps

1. Mount the housing cover.
2. Check the pump head and pneumatic connections for leaks.
3. Properly dispose of the replaced structured diaphragm and valve plates/seals.



### NOTICE

To ensure the required gas tightness of the pump following servicing, a leak test is to be performed.



### WARNING

Risk of explosion from leaks

- Before recommissioning the pump, check the pump heads and pneumatic connections for leaks. Leaks may lead to a risk of explosion.



### WARNING

Risk of injury and poisoning from leaks

- Before recommissioning the pump, check the pump heads and pneumatic connections for leaks. Leaks may lead to poisoning, chemical burns or similar injuries.



Before recommissioning, observe the applicable standards, guidelines, regulations and technical standards at the electrical connection.

## 10 Troubleshooting



**DANGER**

Danger: electric shock can be life-threatening.

- All work on the pump may only be performed by an authorized specialist.
- Before working on the pump: Disconnect the pump from the power supply.
- Check and ensure that no voltage is present.

- Allow the pump to cool before troubleshooting.
- Check the pump (see following tables).
- Also observe the operating instructions for the motor when troubleshooting.

Pump not delivering	
Cause	Troubleshooting
Pump is not connected to the electrical mains.	→ Connect the pump to the electrical mains.
No voltage in the electrical mains.	→ Check the circuit breaker for the room and switch it on if necessary.
Pneumatic connections or lines are blocked.	→ Check the pneumatic connections and lines. → Remove the blockage.
External valve is closed or filter clogged.	→ Check external valves and filters.
Condensation has collected in the pump head.	→ Separate the source of the condensation from the pump. → Flush the pump with air at atmospheric pressure for a few minutes (if necessary for safety reasons: with an inert gas). → Install the pump at the highest location in the system.
Diaphragm or valve plate/seal is worn.	→ Change the diaphragm and the valve plate/seal (see Chapter 9 <i>Service</i> ).

Tab.20

<b>Flow rate, pressure or vacuum too low</b>	
<b>The pump does not reach the performance stated in the technical data or data sheet.</b>	
<b>Cause</b>	<b>Troubleshooting</b>
Condensation has collected in the pump head.	<ul style="list-style-type: none"> <li>→ Separate the source of the condensation from the pump.</li> <li>→ Flush the pump with air at atmospheric pressure for a few minutes (if necessary for safety reasons: with an inert gas).</li> <li>→ Install the pump at the highest location in the system.</li> </ul>
There is overpressure on the pressure side and at the same time vacuum or pressure above atmospheric pressure on the suction side.	<ul style="list-style-type: none"> <li>→ Change the pneumatic conditions.</li> </ul>
Pneumatic lines or connection parts have insufficient cross-section or are throttled	<ul style="list-style-type: none"> <li>→ Disconnect the pump from the system to determine the output values.</li> <li>→ Eliminate any constriction (e.g. valve).</li> <li>→ Use lines or connection parts with a larger cross-section if necessary.</li> </ul>
Leaks occur at pneumatic connections, lines or pump head.	<ul style="list-style-type: none"> <li>→ Eliminate the leaks.</li> </ul>
Pneumatic connections or lines are partially or completely blocked.	<ul style="list-style-type: none"> <li>→ Check the pneumatic connections and lines.</li> <li>→ Remove any parts or particles that are causing blockages.</li> </ul>
Head parts are soiled.	<ul style="list-style-type: none"> <li>→ Clean the head components.</li> </ul>
Diaphragm or valve plate/seal is worn.	<ul style="list-style-type: none"> <li>→ Change the diaphragm and the valve plate/seal (see Chapter 9 <i>Servicing</i>).</li> </ul>
Working diaphragm broken	<ul style="list-style-type: none"> <li>→ Stop the pump immediately.</li> </ul>
Pump exhibiting changed running noises and vibrations.	<ul style="list-style-type: none"> <li>→ Stop the pump immediately.</li> <li>→ Contact KNF Customer Service.</li> </ul>

Tab.21

<b>Pump exhibiting changed running noises and vibrations</b>	
<b>Cause</b>	<b>Troubleshooting</b>
Pump bearing worn or defective.	<ul style="list-style-type: none"> <li>→ Determine the cause.</li> <li>→ Contact KNF Customer Service.</li> </ul>
Motor worn or defective.	<ul style="list-style-type: none"> <li>→ See operating instructions for motor.</li> </ul>

Tab.22

**Fault cannot be rectified**

If you are unable to identify any of the specified causes, send the pump to KNF Customer Service (contact data: see [www.knf.com](http://www.knf.com)).

1. Flush the pump with air for a few minutes (if necessary for safety reasons: with an inert gas) at atmospheric pressure in order to remove hazardous or aggressive gases from the pump head (see Chapter 9.2.1 *Flushing the pump*).
2. Clean the pump (see Chapter 9.2.2 *Cleaning the pump*).
3. Send the pump together with completed Health and Safety Clearance and Decontamination Form to KNF, specifying the pumped medium.

## 11 Spare parts and accessories

**i** To order spare parts and accessories, please contact your KNF sales partner or KNF Customer Service (contact data: see [www.knf.com](http://www.knf.com)).

### 11.1 Spare parts

#### Spare part set

A spare part set consists of:

Spare part	Quantity
Valve plate/seal	2
Structured diaphragm	1

*Tab.23 Spare parts N87*

Spare part set	Order number
N87	322292

*Tab.24 Spare part set N87*

### 11.2 Accessories

Description	Order number
Hose connector for hose ID 6 (PVDF, G 1/8)	014052
Male connection OD 6 (PVDF, G 1/8)	014049

*Tab.25*

## 12 Returns

### Preparing for return

1. Flush the pump with air for a few minutes (if necessary for safety reasons: with inert gas) at atmospheric pressure to free the pump head of dangerous or aggressive gases (see Chapter 9.2.1 *Flushing the pump*).

**i** Please contact your KNF sales partner if the pump cannot be flushed due to damage.

2. Remove the pump.
3. Clean the pump (see Chapter 9.2.2 *Cleaning the pump*).
4. Send the pump together with the completed Health and Safety Clearance and Decontamination Form to KNF, stating the nature of the transferred medium.
5. Pack the device securely to prevent further damage to the product. If necessary, request original packaging for a fee.

### Returns

KNF shall undertake to repair the pump only under the condition that the customer presents a certificate regarding the medium that is pumped and the cleaning of the pump. In this case too, old devices can be returned. Please follow the instructions at [knf.com/repairs here](https://knf.com/repairs).

Contact your KNF sales partner directly if you require additional support for your return service.

## **13 Appendix**

→ *13.1 Declaration of Conformity*

→ *13.2 Motor*

### **13.1 Declaration of Conformity**

**For further information, see also**

- Konformitätserklärung N87EX.pdf

**EG / EU – Konformitätserklärung / EC / EU declaration of conformity**

Hiermit erklärt der Hersteller:

Herewith the manufacturer:

KNF Neuberger GmbH, Alter Weg 3, D-79112 Freiburg

dass folgende Membranpumpen,  
declares that the following diaphragm pumps:

(Seriennummer siehe Typenschild / Serial number see type label)

Pumpentyp(en) / Pump type(s):

N87TT.9E EX

N87TT.9E 5L EX

allen einschlägigen Bestimmungen folgender Richtlinien entspricht:

is in conformity with the following Directives:

Richtlinie 2006/42/EG Maschinen

Directive 2006/42/EC machinery

Richtlinie 2011/65/EU zur Beschränkung der Verwendung bestimmter gefährlicher Stoffe in Elektro- und Elektronikgeräten (Anhang II geändert durch die Delegierte Richtlinie (EU) 2015/863 der Kommission)

Directive 2011/65/EU on the restriction of the use of certain hazardous substances in electrical and electronic equipment (Annex II amended by Commission Delegated Directive (EU) 2015/863)

Richtlinie 2014/30/EU über elektromagnetische Verträglichkeit

Directive 2014/30/EU about the electromagnetic compatibility

Folgende harmonisierte Normen wurden zugrunde gelegt:

The following harmonized standards have been applied:

EN 1012-2: 1996 + A1:2009

EN IEC 63000: 2018

Bevollmächtigter für die Zusammenstellung der technischen Unterlagen:

Authorised person to compile the relevant technical documentation:

R. Köpfer, Product Qualification, KNF Neuberger GmbH, Alter Weg 3, D-79112 Freiburg

Die Membranpumpen, fallen ebenso in den Anwendungsbereich der folgenden Richtlinie:

The diaphragm pumps falling in the scope of the following Directive as well:

Richtlinie 2014/34/EU für Geräte und Schutzsysteme zur bestimmungsgemäßen Verwendung in explosionsgefährdeten Bereichen

Directive 2014/34/EC relating to equipment and protective systems intended for use in potentially explosive atmospheres.

Die zugehörigen Konformitätserklärungen für den:

The corresponding conformity declaration for:

nichtelektrischen Pumpenteil: siehe Seite 2/3 dieser Erklärung

non-electrical part of the pump: see page 2/3 of this declaration

elektrischer Teil - Motor: siehe Seite 3/3 beiliegendes Dokument des Motorenherstellers

electrical part – motor: see page 3/3 enclosed document of motor supplier

Freiburg, 08.05.2023

Ort, Datum (TT.MM.JJJJ)  
place, date (dd.mm.yyyy)

CO R&D

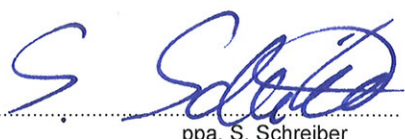

ppa. S. Schreiber



**EU – Konformitätserklärung / EU declaration of conformity**

Hiermit erklärt der Hersteller:

Herewith the manufacturer:

KNF Neuberger GmbH, Alter Weg 3, D-79112 Freiburg  
dass folgende Membranpumpen – nichtelektrischer Pumpenteil,  
declares that the following diaphragm pumps – non-electrical part:  
(Seriennummer siehe Typenschild / Serial number see type label)

Pumpentyp(en) / Pump type(s):

N87TT.9E EX

Kennzeichnung:  
Marking:



II 2/2G Ex h IIB+H2 T3 Gb

N87TT.9E 5L EX

Kennzeichnung:  
Marking:



II 2/2G Ex h IIB+H2 T4 Gb

allen einschlägigen Bestimmungen folgenden Richtlinie entspricht:

is in conformity with the following Directive:

Richtlinie 2014/34/EU für Geräte und Schutzsysteme zur bestimmungsgemäßen Verwendung  
in explosionsgefährdeten Bereichen

Directive 2014/34/EC relating to equipment and protective systems intended for use in potentially  
explosive atmospheres.

Entsprechend Artikel 13 (1) b) ii) der RL2014/34/EU ist die technische Dokumentation bei der  
notifizierten Stelle Physikalisch-Technische Bundesanstalt PTB, Nr. 0102 hinterlegt.

According to article 13 (1) b) ii) of the directive 2014/34/EU, the technical documentation is deposited at the  
Physikalisch-Technische Bundesanstalt PTB, notified body no. 0102.

Folgende harmonisierte Normen wurden zugrunde gelegt:

The following harmonized standards have been applied:

EN ISO 80079-36:	2016
EN ISO 80079-37:	2016
EN 1127-1:	2019





**ORANGE 1 ELECTRIC MOTORS S.P.A.**

Via Mantova 93 43122 Parma Italy

Te. +39 (0)521 272383

www.orange1.eu





**Dichiarazione UE di Conformità / UE Declaration of Conformity / Déclaration UE de Conformité  
UE Konformitätserklärung / Declaration UE de Conformidad**

*I motori elettrici asincroni / Electric asynchronous motors / Les moteurs électriques asynchrone  
Elektrische asynchron motoren typ / Los motores electricos asincronos del tipo*

**Serie O-M**

*Che riportano una delle marcature*

*Bearing one of the marks / Marques / Kennzeichnung / Que llevan una de los marcados*

EU Type Examination certificate (according to Annex III of the ATEX Directive 2014/34/EU)		EPT 17 ATEX 2588 X
CE	0477  II 2G Ex db IIC T5... T3 Gb	
CE	0477  II 2GD Ex db IIC T5... T3 Gb Ex tb IIIC T125°C Db	
CE	0477  II 2G Ex db eb IIC T5... T3 Gb	
CE	0477  II 2GD Ex db eb IIC T5... T3 Gb Ex tb IIIC T125°C Db	

*Sono dichiarati conformi sotto l'esclusiva responsabilità del costruttore/ They are declared compliant under the sole responsibility of the manufacturer / Ils sont déclarés conformes sous la seule responsabilité du fabricant / Sie werden unter der alleinigen Verantwortung des Herstellers als konform erklärt./Se declaran conformes bajo la exclusiva responsabilidad del fabricante.*

**ORANGE 1 ELECTRIC MOTORS S.P.A.**

*in accordo alle seguenti Direttive CE/in compliance with the EC Directives/ selon les Directives CE suivantes  
in Übereinstimmung mit den folgenden EG-Richtlinien/de acuerdo con las siguientes Directivas EC*

2014/34/UE	(ATEX)
2014/30/UE	(EMC)
2006/42/EC	(Machinery)
2015/863 / EU	(RoHS III)
(EU) 2019/1781	(Ecodesign Requirements )

*e in conformità alla seguenti Norme/ and comply with the following Standards / et en conformité avec les Normes  
und entsprechen den folgenden Standard / y conform a las siguientes Normas*

EN IEC 60079-0:2018, EN 60079-1:2014, EN 60079-31:2014, EN 60079-7:2015+A1:2018  
EN 60034-1,2,5,6,7,9,12,14, IEC60072-1,

**NOTA/ NOTE/ BEMERKUNG/ NOTAS**

*(Directive 2006/42/EC Direttiva Macchine, Machinery Directive, Directive Machine, Maschinen-Richtlinie, Directiva Maquinaria)*

*I motori in oggetto sono considerati componenti, in accordo con la direttiva macchine. Il motore non deve essere messo in servizio  
finché la macchina stessa su cui è montato non venga dichiarata conforme alla direttiva macchine.*

*Above motors considered as components, comply with the directive machine. The motor must not be incorporated in service until the machine  
itself has not been declared in conformity with the machinery directive.*

*Les moteurs ci-dessus considérés comme composants sont conformes à la directive machine. Le moteur ne peut être incorporé  
et mis en service avant que la machine dans laquelle il est incorporé ne soit déclarée conforme à la directive machine.*

*Für die korrekte installation der oben genannten Motore sowie der entsprechenden komponenten, die in ihrer Bauart mit den zu dieser  
Bescheinigung aufgeführten Vorschriften übereinstimmen, ist der Maschinenhersteller/Maschinenbetreiber verantwortlich. Die Motoren  
entsprechen den Vorschriften nur, solange die Anlage, in der sie eingebaut wurden, in Übereinstimmung mit den geltenden Maschinen-  
richtlinien und Vorschriften errichtet wurde.*

*Los motores en objeto, por tratarse de componentes, cumplen las normas de la directiva si la instalacion está correctamente controlada por el  
constructor de la máquina. El motor no debe entrar en servicio hasta que la máquina en que ha sido incorporado disponga de la declaración de  
la directive maquinaria*

*Product Quality Assurance Notification Number (according to Annex IV of the ATEX Directive 2014/34/EU): EPT 21 ATEX 4234 Q  
Notified by Euroins Product Testing Italy S.r.l. - Notified Body n.0477 - Via Courgné 21 - 10156 Torino Italy*

28/06/2021

Armando Donazzan  
Legale Rappresentante

## 13.2 Motor

### For further information, see also

- Betriebsanleitung Motor.pdf
- CE und Anschlussplan Motor.pdf
- IEC-EX.pdf





## 1. GENERAL SAFETY INFORMATION

⚠ These safety instructions refer to the installation, utilization and maintenance of motors O-M series to be used in potentially explosive areas with presence of combustible GAS and/or DUST. The information of these instructions are only for qualified personnel. Except for the opening of terminal cover, any other opening cancels the warranty conditions of the motors.

Here below you can see the different markings of the motors and the different zones where they can be used:

GAS	Markings	Zones
	II 2G Ex db IIC T3 Gb T.amb -40°C , +60°C	Zones 1, 2
	II 2G Ex db IIC T4 Gb T.amb -40°C , +60°C	
	II 2G Ex db IIC T5 Gb T.amb -40°C , +40°C	
	II 2G Ex db eb IIC T3 Gb T.amb -40°C , +60°C	
	II 2G Ex db eb IIC T4 Gb T.amb -40°C , +60°C	
DUST	II 2D Ex tb IIC T125°C T.amb -40°C , +60°C (maximum thickness of dust layer 5mm)	Zones 21, 22

The motors comply with the Essential Health and Safety Requirements for potentially explosive atmospheres provided by European Standards:

IEC/EN 60079-0, IEC/EN 60079-1, IEC/EN 60079-7, IEC/EN 60079-31

⚠ Electric rotating machines present dangers from live and rotating parts, and probably very hot surfaces. All work on them including transportation, connection, commissioning and maintenance must be by qualified and responsible specialists (IEC 364 must be observed). Inadequate work can lead to severe damage to persons and property.

⚠ It is imperative to observe the data printed on the nameplate before operating the motor. Low voltage motors are components to be installed into machines in accordance with Directive 2006/42/EC.

Commissioning is not allowed until the conformity of the end product with this directive has been established.

These asynchronous motors comply the EMC (2014/30/UE) Directive and no particular shielding is necessary when connected to a pure sinewave voltage supply.

⚠ Before working on the motor, ensure it has stopped and is disconnected from the power supply (including auxiliary equipment). If there is any form of automatic starting, automatic resetting, relays or remote starting, avoid any possibility of unexpected re-starting, paying attention to specific recommendations on equipment application.

## 2. TRANSPORT, STORAGE

⚠ On receipt verify that the motor has not been damaged during transport and in this case avoid any installation and communicate immediately to the transport service.

Eyebolts, when provided with the motor, must be tightened properly as they are suitable only for lifting the motor, no additional loads are allowed to be attached. If necessary use sufficiently dimensioned devices as a means of transport.

Do not use any projection of the motor body to hang the motor for transport purposes.

If two eyebolts are present on the motor use both for lifting.

Store low voltage motors in a dry, dust free and low vibration (v eff <0,2 mm/s) area to prevent bearing damage. Before commissioning, the insulation resistance must be measured. In case of values < 1,5 MΩ the winding must be dried. Contact our technical department directly for information on the drying procedure.

## 3. INSTALLATION

⚠ Installation must comply with the rules of the standard IEC/EN 60079-14 or with the national standards (edition into effect).

Before the installation in an explosive atmosphere, the installer must ensure that the motor is suitable for the classified area in consideration of the different inflammable substances present in the installation area (**please verify the marking on the motor plate before installation**).

The motor must be installed only by qualified people with knowledge about electrical apparatus for explosive gas atmospheres and electrical installations in hazardous areas and has to be done with the motor and driven machine at standstill, electrically dead and locked against restart.

The rating on the nameplate corresponds to voltage and frequency of the power supply and all other electrical and mechanical data, as well as the safety data regarding the motor (protection type, temperature class, ambient temperature etc.).

### WARNING: DO NOT OPEN IN PRESENCE OF EXPLOSIVE ATMOSPHERE

The coupling components must also be balanced with a half key on a smooth mandrel. Coupling belts and pulleys must be assembled by suitable tools to protect the bearings.

After assembly check that the coupling components are well fixed on the shaft end; they must be properly pushed against the shaft shoulder. Where the hub of the coupling gear is shorter than the shaft end, compensate the difference by use of a bush spacer.

Too large or too small pulleys can impair the shaft bearing life; similarly excessive belt tension can cause low bearing life or shaft breakage.

The motors must be installed in a proper position so that cooling air can go in and out easily. The ventilation must not be hindered and the outgoing air - also from adjacent units - must not be directly sucked in again. To keep a good cooling of the motor, there must be a minimum distance of 40mm between the fan cover and another element capable to reduce the air aspiration of the ventilation. Avoid heat sources near the motor that might affect the temperatures both of cooling air and of the motor.

In case of outdoor installation protect the motor from solar radiation and extremes of weather. In case of vertical mounting with shaft down use fan cover with rain roof. It is advisable to protect the motor with such as overcurrent devices and torque limiters where it is not protected by winding temperature transducers connected to appropriate switchgear.

In case of environments with wide thermal excursions and when can be preview the presence of moisture, Orange1 EM will equip the motor with heaters.

Instead of use anti-condensation heaters, is possible to supply the motor on pins U1-V1 with a voltage 4-10% of the rated motor phase-voltage; 20-30% of the rated current is enough to heat the motor.

⚠ Check the direction of rotation with the motor not coupled fastening the shaft key to avoid its violent ejection during rotation.

If the direction of rotation is not as desired, disconnect the motor and wait until the motor is completely stopped:

- in case of three phase motors interchange two phases at the terminals.
- in case of single phase motors refer to the diagram supplied with the motor

### Cable entries

⚠ Depending on the type of protection of the motor the cable entries shall comply with the standards written in the table and having the range of temperature of the motor itself:

Type of protection of the terminal box	Type of protection of the cable gland	Operative Temp.
Ex eb tb	Ex eb tb	-40°C , +100°C
Ex db tb	Ex db tb	-40°C , +100°C

The cable diameter for each size of cable gland are like below:

Cable gland thread	Motor size	Range of cable diameter (mm)
M16x1.5	56-63-71-80-90-100-112	6-12
M20X1.5	56-63-71-80-90-100-112	6-12 / 9-16
M25X1.5	132	12,5-20,5
M32X1.5	160-180	17-26

Cable glands and plugs if not supplied with the motor shall be like above.

The cable gland mounted on the terminal box shall be covered by a valid ATEX and IECEx certificate according to the type of protection of the terminal compartment (Ex db and/or Ex eb and/or Ex tb). It shall have a minimum protection degree IP66 according to EN/IEC 60529 and EN/IEC 60079-0; the operating temperature of the cable gland shall be included in the temperature range defined by the minimum ambient temperature reported on the Ex Label of the motor and the maximum ambient temperature + 25°C.

**The cable glands shall be completely screwed to the motor with a tightening torque of 5Nm**

- The field wiring shall be carried out using cables having an overall sheath operating temperature at least equal to the maximum ambient temperature of the motor +25°C and conductor insulation temperature at least equal to the maximum ambient temperature of the motor +35°C.

Capacitor housing cable glands and motor wires cable glands inside Ex enclosures are factory installed. It is not allowed to unscrew or modify the factory installation.

As the feet can be mounted on the frame it is possible to fix them in 3 different positions so to have the possibility to have the terminal box on the top or on the right and left sides of the motor.

At the same time the terminal box can be mounted on the motor so to have the cable entries where it is necessary. So the cable entries can be in the four different positions. This operation has to be done before connection, removing the box cover, unscrewing the 4 screws that fix the box to the motor. Screw completely in respect of the tightening torque of TIGHTENING TORQUE TABLE

### 4. CONNECTION TO THE POWER SUPPLY

⚠ Only qualified people are allowed to connect the motor to the power supply. The connection to the electric supply must be done by through the cable entry supplied with the motor or through another type of cable entry certified in accordance with the European Standards showed above in compliance with Directive 2014/34/EU and IECEx approved.

In case of motor complete with cable, the free end of the cable should be connected in a safe zone or inside an Ex enclosure with a type of protection suitable for the explosive atmosphere.

⚠ Always refer to the data printed on the nameplate for voltage and frequency to ensure the motor is appropriate for the mains supply.

If not specified it is possible to assume tolerances of ±5% on voltage and ±1% on frequency indicated on the nameplate (X on the certificate number

The connection diagrams are normally supplied together with the motor or are printed in the terminal box. If they are missing please refer to this manual or contact directly to our technical office.

Check and make sure that, in the case of star /delta start, the switching from star to delta can only be executed after the starting current of the star step has fallen; this is important because of the risk of not allowed operational loads.

The cable size choice must be suitable to the motor ratings and the plant type.

The motors shall be protected by a tripping device, which in case of breakdown could cut off the power supply before the surface temperature exceeds the ignition temperature of the explosive atmosphere.

⚠ The motors with increased safety terminal box ("eb") are built with a special terminal board with improved insulation and distances.

⚠ The Ex d motors have a normal terminal board.

### TIGHTENING TORQUE TABLE

Thread	M4	M5	M6	M8
Tightening Torque (Nm)	1,5	2	3	6

The power connection shall be made as in the picture. The nuts shall have to be tightened according to TIGHTENING TORQUE TABLE to avoid any loosening.

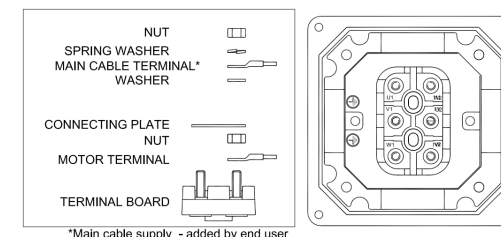

**IMPORTANT: Motors with Ex eb terminal box REPLACE THE GASKET (SEAL) IN THE RIGHT POSITION BEFORE CLOSING THE TERMINAL BOX AND SCREW COMPLETELY ALL THE SCREWS.**

### Earth connection

⚠ In addition to the earth screw terminal fitted inside the terminal box, another external one must be on the motor frame. If the line conductors have a section S the earth connections have to be:

Earth conductor	Line conductors
= S	S ≤ 16 mm <sup>2</sup>
16	16 mm <sup>2</sup> < S ≤ 35 mm <sup>2</sup>
≥ 0,5 S	S > 35 mm <sup>2</sup>

### Connection of auxiliary cables ("e" terminal box)

⚠ If the motor is provided with terminal board with auxiliary pins the connection of thermal protection and/or heaters can be made in such pins.

If the motor is provided with just a terminal board having just the 6 mains pins the connection of thermal protection and heaters have to be made by welding the wires of auxiliary devices with the wires of the cable and insulate using a heat-shrink sheath.

#### Protection

**Ex** The motor must be protected by a tripping device that in case of breakdown, cut off the supply of the motor so that the surface temperature of the parts in contact with the explosive atmosphere doesn't reach the ignition temperature.

#### Motors for inverter duty

**Ex** In case the motors are supplied by inverter, they shall be provided with protectors inside the windings (normally PTC thermistors), capable of assuring the respect of temperature class limits. Such devices shall be connected to a control device able to cut off power to the motor in case of reaching of the limit temperature. The permissible operating characteristics in this mode are stated on the nameplate or an additional label. Output filters must be installed based upon the length of the cable on the motor side of the VFD. Filter selection and the maximum cable length depend on the instructions and data provided by the VFD manufacturer. To prevent stray circulating currents, it is recommended to use appropriate measures on the power supply that allow to significantly reduce the triggering cause. For this purpose contact your local VFD supplier.

#### Heaters

**Ex** The heaters shall be supplied only when the motor is not under power. The cables have to be adequate for a power of 25W with supply that can be from 110V up to 240V (±10%).

#### Permissible load

Assuming a life-span of 20.000h for 2P motors and 40.000h for 4,6,8P motors:

Motor size	Bearing	*Max radial load in L/2	*Max axial load Thrust	*Max axial load Pull
63	6202	365	230	120
71	6202	450	280	160
80	6204	590	370	220
90	6205	645	400	230
100	6206	920	560	350
112	6306	1280	700	480
132	6308	1345	770	590
160	6309	2465	1401	714
180	6310	3000	1498	615

\* Values in [N]

#### Allowed duty services

**S1:** Continuous duty the motor works at a constant load until thermal equilibrium is reached.

**S2:** Intermittent duty: Once started, the motor works at a constant load for a limited period and thermal equilibrium is not reached. Motor will be started a second time then when its temperature has decreased to room temperature.

**S3:** Intermittent duty: A sequence of identical duty cycles, made up with a time of operation at constant load and a time at rest. When at rest, the motor is not fed. Starting current does not significantly influence temperature rise.

**S9:** Load and speed vary periodically within the permissible operating range. Frequent overloading may occur. Typical of motors supplied by inverter.

#### Motors with forced ventilation (IC416)

In case of motors with forced ventilation, the main motor can be supplied only when the auxiliary ventilation is already working.

## 5. MARKING

<b>CE</b> (*)	Marking of conformity to the European Directives	
<b>Ex</b> (*)	Specific marking of explosion protection	
II (*)	Motor for surface plants (different from mines)	
<b>2</b> (*)	Category 2: high level of protection	
<b>GAS</b>	<b>G</b> (*)	explosive atmosphere due to presence of combustible gas vapour or mist
	<b>Ex db</b>	Flameproof motor and terminal box
	<b>Ex dbeb</b>	Flameproof motor, increased safety terminal box
	<b>IIC</b>	Gas group, suitable for IIB and IIA
<b>DUST</b>	<b>T3, T4, T5</b>	Temperature class
	<b>D</b> (*)	explosive atmosphere due to presence of combustible dust
	<b>Ex tb IIC</b>	tb enclosures suitable for zone 21 (cat. 2D)
	<b>T125 °C</b>	Max surface temperature
	<b>T.amb</b>	Ambient temperature
<b>AB xx yyy</b>	AB : laboratory which issues the CE type certificate xx : year of issue of certificate yyy : number of CE type certificate	
<b>ZZZZ</b> (*)	Notified Body that gives the Product Quality Assurance Notification	
(*) Only for ATEX marking		

## 6. MAINTENANCE AND REPAIR

**Ex** **MAINTENANCE** shall be performed only by qualified people in accordance with the standard IEC/EN 60079-17 or national standards (last edition).

Qualified people must have knowledge about electrical apparatus for explosive atmospheres and electrical installations in hazardous areas.

- Every 3000 hours of service verify and restore, if necessary, the grease on the radial seals (for example V-rings).

Periodically (depending on the environment and duty) verify:

- motor cleanliness (oil, DUST, dirt and machining residuals absence) and free passage of cooling air  
- correct tightening of electrical connections, of fastening screws

- free motor running with low vibration ( $v_{eff} < 3,5 \text{ mm/s}$  for  $P_n < 15 \text{ kW}$   $v_{eff} < 4,5 \text{ mm/s}$  for  $P_n > 15 \text{ kW}$ ) and absence of anomalous noises; where there is high vibration and/or noise verify the motor fastenings, machine balancing and that the bearings are in good condition.

- The bearings must be inspected once per 3000h operation.

**Ex** **REPAIRS** shall be made in accordance with the rules as defined in EN 60079-19 standard.

These repairs can only be done under the control and authorization of Orange1 EM or by certified repair workshop.

When the repair is made by a certified repair workshop, they must respect all the original characteristic of the motor and use only original spare parts.

Furthermore they have to place an additional nameplate on the motor with written a symbol to identify the repair, company name and certification, repair operation number and date.

Nothing regarding the type of protection can be modified.

In case all these rules are not respected, the motor loses all its characteristic of certification.

**FLAMEPROOF JOINTS CANNOT BE REPAIRED**

## 7. MODULAR COMPONENTS

The motors are completely modular.

Feet and flanges can be mounted without affecting the ATEX certificate, as they are external and are not part of the type of protection.

In the table here below we show you the screws to be used to mount the different modular components.

Motor Size	Flange	Feet	Terminal box Cover
63-71	M5x16	M6x16	M5x14
80-90	M6x20	M6x20	M5x14
100	M8x20	M8x30 DADO M8	M5x14
112	M8x20	M8x35 NUT M8	M5x14
132	M10x20	M10x50 NUT M10	M6x16
160	n.3 M10x95 n.1 M10x70	M10x70 + NUT M10	M6X20
180	n.3 M10x95 n.1 M10x70	M10x70 + NUT M10	M6X20
Screws class 8.8			

## 8. MANUFACTURING DATE

The manufacturing date is shown on the motor nameplate indicating Month and year of manufacture: MM-YY





## Dichiarazione UE di Conformità / UE Declaration of Conformity / Déclaration UE de Conformité UE Konformitätserklärung / Declaration UE de Conformidad

*I motori elettrici asincroni / Electric asynchronous motors / Les moteurs électriques asynchrone  
Elektrische asynchron motoren typ / Los motores electricos asincronos del tipo*

### Serie O-M

*Che riportano una delle marcature*

*Bearing one of the marks / Marques / Kennzeichnung / Que llevan una de los marcados*

EU Type Examination certificate (according to Annex III of the ATEX Directive 2014/34/EU)			EPT 17 ATEX 2588 X
<b>CE</b>	<b>0477</b>		<b>II 2G</b> <b>Ex db IIC T5... T3 Gb</b>
<b>CE</b>	<b>0477</b>		<b>II 2GD</b> <b>Ex db IIC T5... T3 Gb</b> <b>Ex tb IIIC T125°C Db</b>
<b>CE</b>	<b>0477</b>		<b>II 2G</b> <b>Ex db eb IIC T5... T3 Gb</b>
<b>CE</b>	<b>0477</b>		<b>II 2GD</b> <b>Ex db eb IIC T5... T3 Gb</b> <b>Ex tb IIIC T125°C Db</b>

*Sono dichiarati conformi sotto l'esclusiva responsabilità del costruttore/ They are declared compliant under the sole responsibility of the manufacturer / Ils sont déclarés conformes sous la seule responsabilité du fabricant / Sie werden unter der alleinigen Verantwortung des Herstellers als konform erklärt./Se declaran conformes bajo la exclusiva responsabilidad del fabricante.*

### ORANGE 1 ELECTRIC MOTORS S.P.A.

*in accordo alle seguenti Direttive CE/in compliance with the EC Directives/selon les Directives CE suivantes  
in übereinstimmung mit den folgenden EG-Richtlinien/de acuerdo con las siguientes Directivas EC*

2014/34/UE	(ATEX)
2014/30/UE	(EMC)
2006/42/EC	(Machinery)
2015/863 / EU	(RoHS III)
(EU) 2019/1781	(Ecodesign Requirements)

*e in conformità alla seguenti Norme/ and comply with the following Standards / et enconfrmité avec les Normes  
und entsprechen den folgenden Standard / y conform a las siguientes Normas*

EN IEC 60079-0:2018, EN 60079-1:2014, EN 60079-31:2014, EN 60079-7:2015+A1:2018  
EN 60034-1,2,5,6,7,9,12,14, IEC60072-1,

#### NOTA/ NOTE/ BEMERKUNG/ NOTAS

*(Directive 2006/42/EC Direttiva Macchine, Machinery Directive, Directive Machine, Maschinen-Richtlinie, Directiva Maquinaria)*

*I motori in oggetto sono considerati componenti, in accordo con la direttiva macchine. Il motore non deve essere messo in servizio  
finché la macchina stessa su cui è montato non venga dichiarata conforme alla direttiva macchine.*

*Above motors considered as components, comply with the directive machine. The motor must not be incorporated in service until the machine  
itself has not been declared in conformity with the machinery directive.*

*Les moteurs ci-dessus considérés comme composants sont conformes à la directive machine. Le moteur ne peut être incorporé  
et mis en service avant que la machine dans laquelle il est incorporé ne soit déclarée conforme à la directive machine.*

*Für die korrekte installation der oben genannten Motore sowie der entsprechenden komponenten, die in ihrer Bauart mit den zu dieser  
Bescheinigung aufgeführten Vorschriften übereinstimmen, ist der Mashinenhersteller/Maschinenbetreiber verantwortlich. Die Motoren  
entsprechen den Vorschriften nur, solange die Anlage, in der sie eingebaut wurden, in übereinstimmung mit den geltenden Maschinen-  
richtlinien und Vorschriften errichtet wurde.*

*Los motores en objecto, por tratarse de componentes, cumplen las normas de la directiva si la instalacion està correctamente controlada por el  
constructor de la máquina. El motor no debe entrar en servicio hasta que la máquina en que ha sido incorporado disponga de la declaration de  
la directive maquinaria*

Product Quality Assurance Notification Number (according to Annex IV of the ATEX Directive 2014/34/EU): EPT 21 ATEX 4234 Q  
Notified by Eurofins Product Testing Italy S.r.l. – Notified Body n.0477 - Via Courgné 21 - 10156 Torino Italy



28/06/2021

Armando Donazzan  
Legale Rappresentante

## Schemi di collegamento / Wiring diagrams

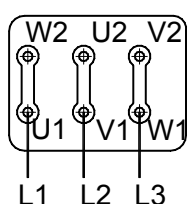
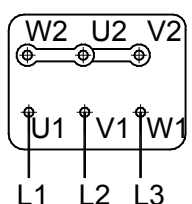
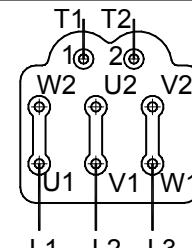
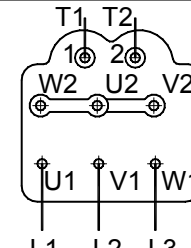
<b>Trifase 1 Velocità 2-4-6-8 poli (6 fili) – Three-phase 1 speed 2-4-6-8 poles (6 wires)</b>			
			
(Δ) Collegamento delta Tensione inferiore Delta connection lower voltage	(Y) Collegamento stella Tensione superiore Star connection higher voltage	(Δ) Collegamento delta Tensione inferiore Delta connection lower voltage	(Y) Collegamento stella Tensione superiore Star connection higher voltage

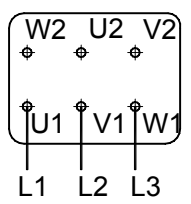
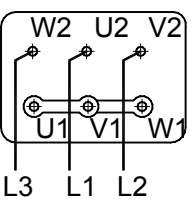
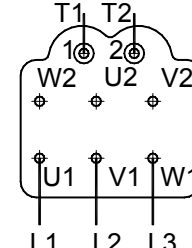
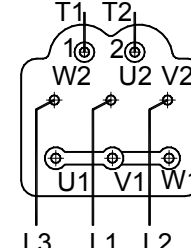
<b>Trifase doppia velocità 1 avvolgimento – Three-phase double speed 1 winding</b>			
			
Bassa velocità – Low speed	Alta velocità – high speed	Bassa velocità – Low speed	Alta velocità – high speed

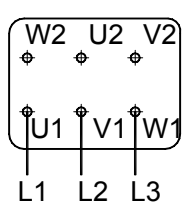
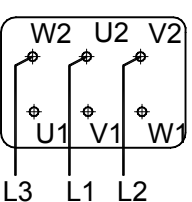
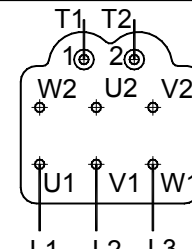
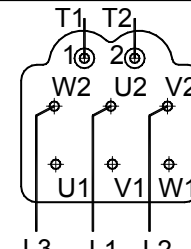
<b>Trifase doppia velocità 2 avvolgimenti separati – Three-phase double speed 2 separate windings</b>			
			
Bassa velocità – Low speed	Alta velocità – high speed	Bassa velocità – Low speed	Alta velocità – high speed

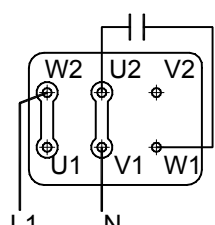
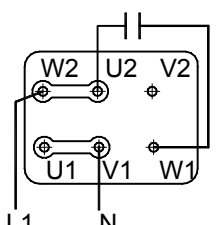
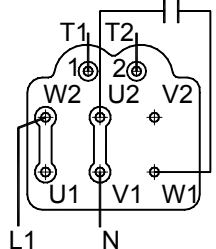
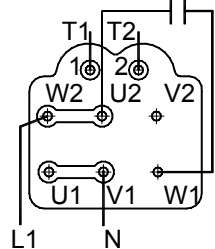
<b>Monofase 4 fili – Single-phase 4 wires</b>		<b>Monofase 4 fili con protezione termica Single-phase 4 wires with thermal protection</b>	
			
Rotazione oraria Clockwise rotation	Rotazione antioraria Counter clockwise rotation	Rotazione oraria Clockwise rotation	Rotazione antioraria Counter clockwise rotation

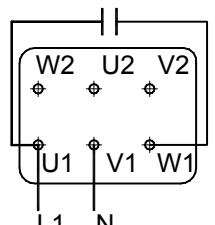
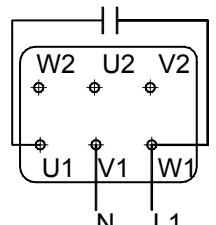
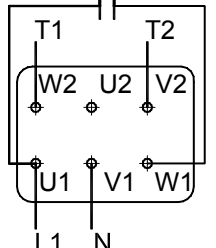
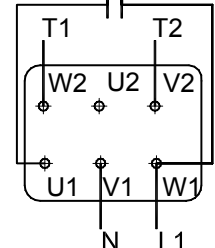
<b>Monofase 3 fili – Single-phase 3 wires</b>		<b>Monofase 3 fili con protezione termica Single-phase 3 wires with thermal protection</b>	
			
Rotazione oraria Clockwise rotation	Rotazione antioraria Counter clockwise rotation	Rotazione oraria Clockwise rotation	Rotazione antioraria Counter clockwise rotation



# IECEx Certificate of Conformity

## INTERNATIONAL ELECTROTECHNICAL COMMISSION IEC Certification System for Explosive Atmospheres

for rules and details of the IECEx Scheme visit [www.iecex.com](http://www.iecex.com)

Certificate No.:	<b>IECEx EUT 14.0001X</b>	Page 1 of 4	<u>Certificate history:</u>
Status:	<b>Current</b>	Issue No: 5	Issue 4 (2022-07-15)
Date of Issue:	2022-12-21		Issue 3 (2021-06-29)
Applicant:	<b>ORANGE1 ELECTRIC MOTORS S.p.A.</b> Via Mantova, 93 43122 Parma <b>Italy</b>		Issue 2 (2019-02-08)
Equipment:	<b>Series O-M three-phase and single-phase asynchronous squirrel cage rotor motors, supplied by mains or inverter</b>		
Optional accessory:	Terminal box and Capacitor box		
Type of Protection:	<b>Flameproof enclosures "d"; Equipment dust ignition protection by enclosure "t", Increased safety "e"</b>		
Marking:	Ex db IIC T5 ... T3 Gb <i>or</i> Ex db IIC T5 ... T3 Gb Ex tb IIIC T125°C Db <i>or</i> Ex db eb IIC T5 ... T3 Gb <i>or</i> Ex db eb IIC T5 ... T3 Gb Ex tb IIIC T125°C Db  -40°C ≤ Tamb ≤ +60°C  Relationships between ambient temperature range and temperature limits are reported in the attachment		

Approved for issue on behalf of the IECEx  
Certification Body:

**Dionisio Bucchieri**

Position:

**Head of IECEx CB**

Signature:  
(for printed version)

Date:  
(for printed version)

1. This certificate and schedule may only be reproduced in full.
2. This certificate is not transferable and remains the property of the issuing body.
3. The Status and authenticity of this certificate may be verified by visiting [www.iecex.com](http://www.iecex.com) or use of this QR Code.



Certificate issued by:

**Eurofins Product Testing Italy S.r.l.**  
Via Cuorgnè  
n.21 - 10156 Torino  
**Italy**

 **eurofins** | Product Testing





# IECEX Certificate of Conformity

Certificate No.: **IECEX EUT 14.0001X**

Page 2 of 4

Date of issue: 2022-12-21

Issue No: 5

Manufacturer: **ORANGE1 ELECTRIC MOTORS S.p.A.**  
Via Mantova, 93  
43122 Parma  
**Italy**

Manufacturing locations: **ORANGE1 ELECTRIC MOTORS S.p.A.**  
Via Mantova, 93  
43122 Parma  
**Italy**

This certificate is issued as verification that a sample(s), representative of production, was assessed and tested and found to comply with the IEC Standard list below and that the manufacturer's quality system, relating to the Ex products covered by this certificate, was assessed and found to comply with the IECEx Quality system requirements. This certificate is granted subject to the conditions as set out in IECEx Scheme Rules, IECEx 02 and Operational Documents as amended

#### STANDARDS :

The equipment and any acceptable variations to it specified in the schedule of this certificate and the identified documents, was found to comply with the following standards

[IEC 60079-0:2017](#) Explosive atmospheres - Part 0: Equipment - General requirements  
Edition:7.0

[IEC 60079-1:2014](#) Explosive atmospheres - Part 1: Equipment protection by flameproof enclosures "d"  
Edition:7.0

[IEC 60079-31:2013](#) Explosive atmospheres - Part 31: Equipment dust ignition protection by enclosure "t"  
Edition:2

[IEC 60079-7:2017](#) Explosive atmospheres - Part 7: Equipment protection by increased safety "e"  
Edition:5.1

This Certificate **does not** indicate compliance with safety and performance requirements other than those expressly included in the Standards listed above.

#### TEST & ASSESSMENT REPORTS:

A sample(s) of the equipment listed has successfully met the examination and test requirements as recorded in:

Test Report:

[IT/EUT/ExTR14.0001/05](#)

Quality Assessment Report:

[IT/EUT/QAR14.0001/10](#)



# IECEX Certificate of Conformity

Certificate No.: **IECEX EUT 14.0001X**

Page 3 of 4

Date of issue: 2022-12-21

Issue No: 5

## **EQUIPMENT:**

Equipment and systems covered by this Certificate are as follows:

The motors are made of aluminium and have separate parts: motor enclosure, terminal box for supply and capacitor enclosure (optional). The motors are suitable for group IIC and group IIIC.

The motor enclosure has types of protection "Ex d" and "Ex t";

The terminal box can have types of protection "Ex d" and "Ex t" or "Ex e" and "Ex t"; A version without terminal box and with a smaller box (flat box) for supply cable connection with splicing or head to head connectors is also available

The capacitor enclosure has types of protection "Ex d" and "Ex t";

See the detailed description in the annexed document to this certificate.

## **SPECIFIC CONDITIONS OF USE: YES as shown below:**

•Supply voltage must be within:

-  $\pm 5\%$  of the nominal value for temperature class T5;

-  $\pm 10\%$  of the nominal value for temperature class T3 or T4.

•Flameproof joints are not intended to be repaired.

•The anti-condensation heater can be activated only when the motor is not powered.



# IECEX Certificate of Conformity

Certificate No.: **IECEX EUT 14.0001X**

Page 4 of 4

Date of issue: 2022-12-21

Issue No: 5

**DETAILS OF CERTIFICATE CHANGES (for issues 1 and above)**

The high efficiency version (IE2) for single phase motors has been included in the scope of the certificate

**Annex:**

[Annex to CoC.pdf](#)



**KNF worldwide**

You can find our local KNF partners at: [www.knf.com](http://www.knf.com)