

OEM

N024

**TRANSLATION OF ORIGINAL
OPERATING AND INSTALLATION
INSTRUCTION
ENGLISH**

DIAPHRAGM PUMP

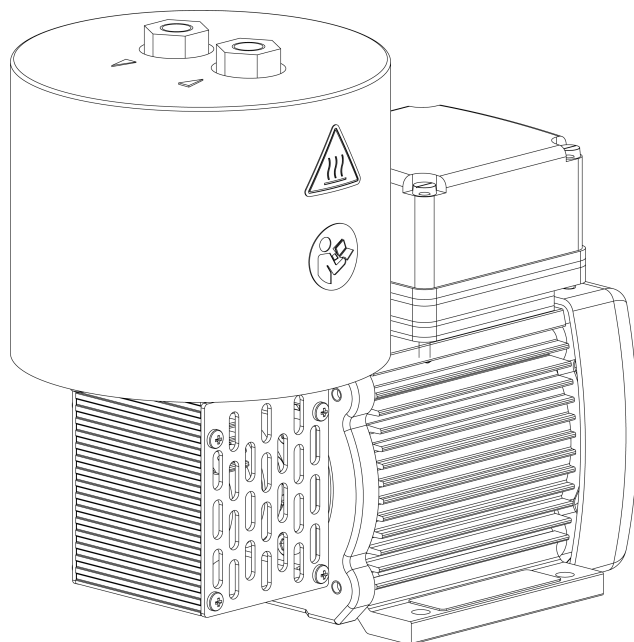

Notice!

Before operating the pump and accessories, read and observe the operating and installation instructions as well as the safety information!

Contents

1	About this document	3
1.1	Using the operating and installation instructions.....	3
1.2	Exclusion of liability.....	3
1.3	Symbols and markings.....	4
2	Safety	6
2.1	Personnel and target group	6
2.2	Responsibility of the operator	7
2.3	Working in a safety conscious manner	7
2.4	Operating conditions	8
2.5	Media	8
2.6	Use.....	9
2.7	Directives and standards	10
2.8	Customer service and repair.....	11
2.9	Disposal	11
3	Technical data.....	12
3.1	Technical data.....	12
4	Product description	15
5	Transport.....	18
	General	18
6	Installation and connection.....	20
6.1	Installing the pump.....	20
6.2	Electrical connection	23
6.3	Pneumatic connection.....	27
7	Operation	29
7.1	General	29
7.2	Information on switching the pump on and off	33
8	Servicing	34
8.1	Servicing schedule.....	35
8.2	Cleaning.....	35
8.3	Replacing diaphragm and valves.....	37
9	Spare parts.....	42
10	Troubleshooting	43
11	Returns.....	47

1 About this document

1.1 Using the operating and installation instructions

The operating and installation instructions are part of the pump.

- In the event of uncertainties with regard to the content of the operating and installation instructions, please contact the manufacturer (contact data: see www.knf.com). Please have the type and serial number of the pump ready.
- Read the operating and installation instructions before you commission the pump.
- Give the operating and installation instructions only completely and unchanged to the next owner.
- Keep the operating and installation instructions within reach at all times.

Project pumps For customer-specific project pumps (pump models that begin with "PJ" or "PM"), there may be deviations from these operating and installation instructions.

- For project pumps, also observe the agreed specifications.

Optional contents Project-specific options may be included in the operating and assembly instructions. These are marked with "Optional". It is also possible that project-specific deviations are not included in the operating and assembly instructions.

1.2 Exclusion of liability

The manufacturer assumes no liability for damages and malfunctions resulting from failure to observe the operating and installation instructions.

The manufacturer assumes no liability for damages and malfunctions resulting from changes or modifications to the device and improper handling.

The manufacturer assumes no liability for damages and malfunctions resulting from impermissible spare parts and accessories.

1.3 Symbols and markings

Warning notice



A notice that warns you of danger is located here.

Possible consequences of a failure to observe the warning notice are specified here. The signal word, e.g., Warning, indicates the danger level.

→ Measures for avoiding the danger and its consequences are specified here.

Danger levels

Signal word	Meaning	Consequences if not observed
DANGER	warns of immediate danger	Death or serious injury or serious damage will result.
WARNING	warns of possible danger	Death, serious injury or serious damage is possible.
CAUTION	warns of a possibly dangerous situation	Minor injury or damage is possible.
NOTICE	Warns of possible damage	Damage is possible.

Tab. 1: Danger levels







Other notices and symbols

→ An activity to be carried out is specified here (a step).

1. The first step of an activity to be carried out is specified here.
Other sequentially numbered steps follow.

i This symbol indicates important information.

Explanation of pictograms

Pictogram	Meaning
	General warning symbol
	Warning of hot surface
	Warning of electrical voltage
	Warning of poisonous substances
	Warning of hand injuries through crushing
	Observe the operating instructions
	General mandatory sign

Tab.2: Explanation of pictograms

2 Safety

i Observe the safety notices in Chapters 6 *Installation and connection* [▶ 20] and 7 *Operation* [▶ 29].

2.1 Personnel and target group

Personnel Make sure that only specially trained and instructed personnel work on the pumps. This applies, in particular, to mounting, connection and servicing work.

Make sure that the personnel have read and understood the operating instructions, particularly the chapter on safety.

Target group	Target group	Definition
	User	Employee
	Specialized personnel	Specialized personnel are personnel who - have relevant professional training in the field covered in the particular section of text; - have current knowledge of the field covered in the particular section of text.

Tab.3: Target group

Who-does-what matrix	Lifecycle phase	User	Specialized personnel
	Transport		X
	Mounting		X
	Connection		X
	Commissioning	X	X
	Operation	X	X
	Servicing		X
	Troubleshooting		X
	Disposal		X

Tab.4: Who-does-what matrix

2.2 Responsibility of the operator

The pumps are produced in accordance with the generally recognized rules of engineering, as well as the occupational health, safety and accident prevention regulations. Nevertheless, dangers can arise during their use that lead to injuries to the user or third parties or to damage to the pump or other property.

Only use the pumps in perfect technical condition, for their intended use, safely and with an awareness of the dangers and in observation of the operating and installation instructions.

The components that are to be connected to the pumps must be designed according to the pneumatic data of the pumps.

When connecting the pumps to the electrical power, observe the corresponding safety rules.

Make sure that no hazardous situation, physical harm or impairment of the pump can occur.

Operating parameters

Only operate and install the pump under the operating parameters and operating conditions described in Chapters 2.4 *Operating conditions* [▶ 8] and 3 *Technical data* [▶ 12].

2.3 Working in a safety conscious manner

Observe the regulations on accident prevention and safety during all work on the pumps and during operation.

Avoid contact with the pump heads and housing parts because the pump heats up during operation.

When working on the pump, make sure that the pump is disconnected from the power and free of voltage.

When connecting the pump to the power supply, observe the corresponding safety rules.

Ensure that no hazards arise from gas flowing when gas connections are open, from the effects of noise or from hot, corrosive, dangerous and environmentally hazardous gases.

Ensure that the pump installation is EMC compliant such that no hazardous situations can occur.

2.4 Operating conditions

Only use the pump in perfect technical condition, for its intended purpose, safely and with an awareness of the dangers and in observation of the operating instructions.

Only install and operate the pumps in accordance with the operating parameters and conditions described in Chapter 3 *Technical data* [▶ 12].

Only pumps that are fully assembled and in the condition as delivered may be operated.

Make sure that the installation location is dry and that the pump is protected from rain, splash water, gushing water, dripping water and other contamination.

Check the tightness of the connections between the pipes of the application and the pump (or the connection of the pump) at regular intervals. Leaky connections carry the risk of releasing dangerous gases and vapors from the pump system.

2.5 Media

Requirements of pumped media

Before transferring a medium, check whether the medium can be transferred without risk in the specific application.

Take note of any change in the state of matter (condensation, crystallization).

Before using a medium, check the compatibility of the media-contacting components (see 3 *Technical data* [▶ 12]) with the medium.

Risk of dangerous gas mixtures during pump operation if diaphragm breaks: Depending on the medium being transferred, breakage of the diaphragm can result in a dangerous mixture if the medium mixes with the air in the compressor housing or the surroundings.

Only transfer gases that remain stable under the pressures and temperatures that arise in the pump.

Handling of hazardous media

Upon breakage of the diaphragm and/or leaks, the transferred medium mixes with the air in the surroundings and/or in the pump housing.

Make sure that a dangerous situation cannot arise as a result.

When pumping hazardous media, observe the safety regulations for the handling of said media.

Handling of combustible media	<p>Note that the pump is not designed to be explosion-proof.</p> <p>Make certain that the temperature of the medium is always sufficiently below the ignition temperature of the medium so as to prevent ignition or explosion. This also applies for abnormal operating situations.</p> <p>Note that the temperature of the medium increases when the pump compresses the medium.</p> <p>Therefore, make certain that the temperature of the medium also remains sufficiently below the ignition temperature of the medium even when it is compressed to the maximum permissible operating pressure of the pump. The maximum permissible operating pressure of the pump is stated in Chapter 3 <i>Technical data</i> [▶ 12].</p> <p>Make certain that the permissible ambient temperature (see 3 <i>Technical data</i> [▶ 12]) is not exceeded.</p> <p>Where applicable, also take into account external energy sources (such as radiated heat sources) that could additionally heat the medium.</p> <p>In case of doubt, contact KNF Customer Service.</p>
-------------------------------	--

2.6 Use

2.6.1 Proper use

The pumps are intended exclusively for transferring gases and vapors.

The pumps are intended exclusively for operation in indoor areas and in non-explosive atmospheres.

2.6.2 Foreseeable misuse

The pumps must not be operated in explosive atmospheres.

The pumps are not suitable for transferring the following:

- Dusts
- Liquids
- Aerosols
- Biological and microbiological substances

- Fuels
- Explosives and flammable materials
- Fibers
- Oxidizing agents
- Foodstuffs.

As standard, the pumps must not be used for simultaneous generation of a vacuum and positive pressure.

This function can be made possible on a project basis following consultation with KNF Customer Service.

Do not apply positive pressure to the inlet of the pump.

This function can be made possible on a project basis following consultation with KNF Customer Service.

2.7 Directives and standards

EU/EC Directives **Declaration of incorporation – for partly completed machinery**

With respect to the Machinery Directive 2006/42/EC, the pumps are partly completed machinery and are, therefore, to be regarded as not ready for use. Partly completed machinery may not be commissioned until it has been determined that the machine into which the partly completed machinery is to be installed complies with the provisions of the Machinery Directive 2006/42/EC. The following fundamental requirements of Annex I of Directive 2006/42/EC (general principles) are applied and observed:

- General principles no. 1
- No. 1.1.2. / 1.1.3. / 1.3.1. / 1.3.3. / 1.3.4. / 1.4.1. / 1.5.1. / 1.5.2. / 1.5.8. / 1.5.9. / 1.7.4. / 1.7.4.1. / 1.7.4.3.

Standards The following standards apply:

- EN IEC 61326-1 – Class A
- EN IEC 61000-3-2
- EN 61000-3-3
- EN 60204-1
- EN IEC 63000

The protective goals of the following directive(s) are achieved:

- Directive 2011/65/EU on the restriction of the use of certain hazardous substances in electrical and electronic equipment (Annex II changed by delegated Directive (EU) 2015/863 of the Commission)
- Directive 2014/35/EU on the harmonization of the laws of the Member States relating to the provision of electrical equipment for use within certain voltage limits on the market

2.8 Customer service and repair

Customer service and repairs

The pump is maintenance-free. However, KNF recommends periodic inspection of the pump for obvious changes in noise or vibration.

Only have repairs to the pumps performed by qualified KNF personnel.

Housings with electrically live components may only be opened by specialist personnel.

Use only genuine spare parts from KNF when performing servicing work.

2.9 Disposal

Environmental protection

Store the pump and all accessories in accordance with the environmental provisions. Observe national and international regulations. This applies in particular to parts that are contaminated with toxic substances.

If you no longer need your packaging materials (e.g. for return shipment or other transport of the device), dispose of them in an environmentally friendly manner.

Old devices must not be disposed of with household waste. Proper disposal and recycling helps to protect natural resources and the environment. The end user is responsible for disposing of old devices according to national and international regulations. Alternatively, KNF products (old devices) may also be returned to KNF for a fee (see chapter 11 *Returns* [p. 47]).

3 Technical data

3.1 Technical data

Pump materials

Assembly	Material AT	Material ST
Wetted head components	Aluminum	Stainless steel
Diaphragm	PTFE	PTFE
Valves	PTFE	PTFE

Tab.5: Pump materials

Pneumatic values

Parameter	Value
Max. permissible operating pressure [bar rel*]	1.5
Ultimate vacuum [mbar abs.]	200
Flow rate at atm. pressure [l/min]**	18

Tab.6: Pneumatic values

*bar rel relative to 1013 hPa

**Liters in the standard state (based on ISO 8778 and ISO 21360-1/2) (1013 hPa, 20°C)

Pneumatic connections

Pump type	Value
N024	Thread size G1/8'

Tab.7: Pneumatic connections

Electrical data

Parameter	Value
Electrical data	See type plate
Electrical protection class of motor (DIN EN 60529 / IEC 60529)	IP44
Electrical protection class of pump heads (.11 version)	IP20

Tab.8: Electrical parameters

*according to spare parts list, see 9 Spare parts [▶ 42]

Thermal switch

i The motors are equipped standard with a thermal switch for monitoring against overheating.

Weight

Pump type	Value [kg]
N024AT.16E	6.1
N024ST.16E	7.3
N024ST.11E	7.3

Tab.9: Weight

Other parameters

Parameter	Value
Permissible ambient temperature [°C]	+ 5 to + 40
Permissible media temperature [°C]	+ 5 to + 240
Dimensions N024.11	See Fig. 4, chapter 6.1 <i>Installing the pump</i> [▶ 20]
Dimensions N024.16	See Fig. 5, chapter 6.1 <i>Installing the pump</i> [▶ 20]
Highest permissible relative air humidity of the environment	80% for temperatures up to 31°C, decreasing linearly to 50% at 40°C.
Maximum installation altitude [m above sea level]	2000

Tab.10: Other parameters

Equipment variants

- .16 versions have temperature-resistant pump heads for media temperatures up to 240°C.
- .11 versions have two heating cartridges that heat the pump head to 240°C (thermostatically controlled).

4 Product description

Design

- 1 Inlet
- 2 Outlet
- 3 Pump head insulation
- 4 Terminal box cover
- 5 Motor

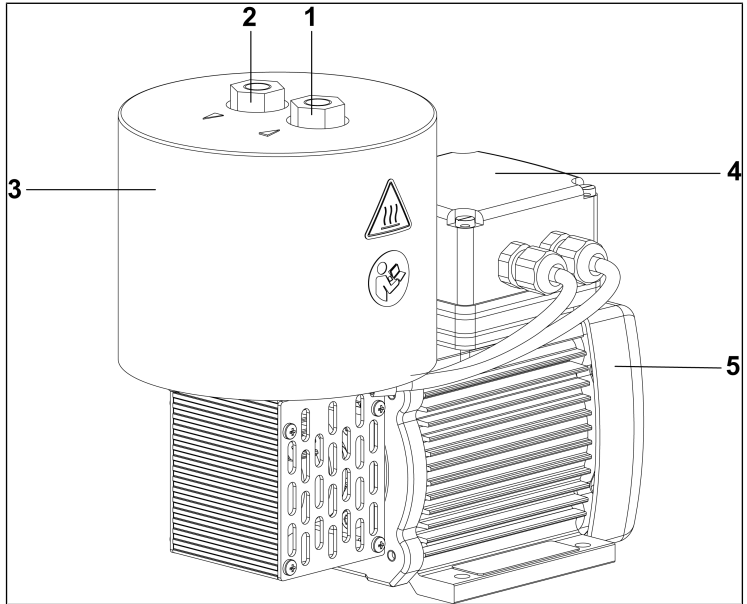

Fig.1: Design N024.11

- 1 Inlet
- 2 Outlet
- 3 Pump head insulation
- 4 Terminal box cover
- 5 Motor

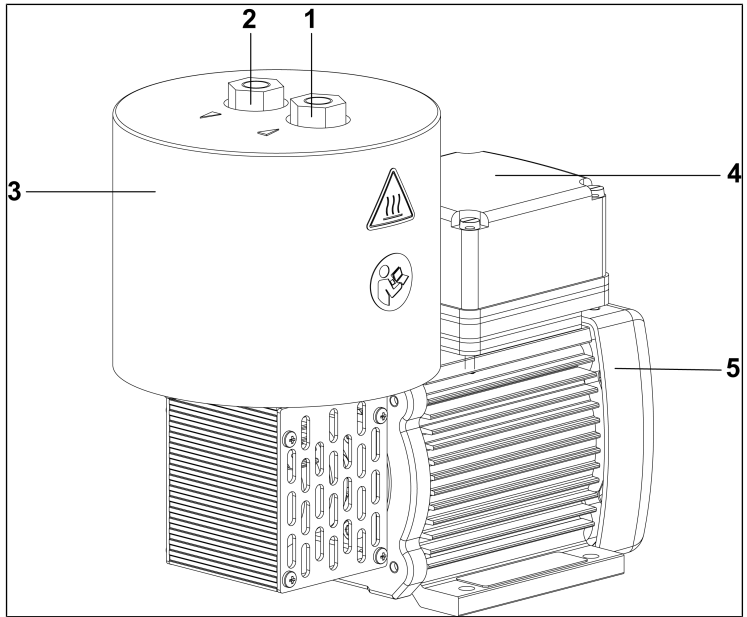

Fig.2: Design N024.16

Function of a diaphragm pump

- 1 Outlet valve
- 2 Inlet valve
- 3 Transfer chamber
- 4 Diaphragm
- 5 Eccentric
- 6 Connecting rod

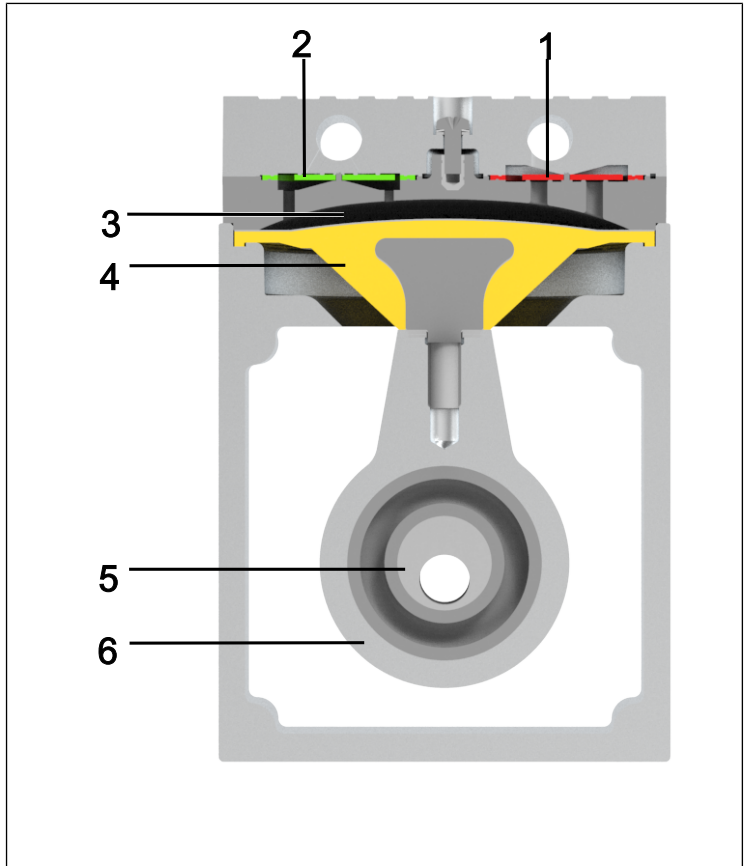

Fig. 3: Function of a diaphragm pump

Diaphragm pumps transfer, compress (depending on the version) and evacuate gases and vapors.

The elastic diaphragm (4) is moved up and down by the eccentric (5) and the connecting rod (6). In the downwards stroke, it aspirates the gas to be transferred via the inlet valve (2). In the upwards stroke, the diaphragm presses the medium out of the pump head via the outlet valve (1). The transfer chamber (3) is separated from the pump drive by the diaphragm.

5 Transport

General



CAUTION

Personal injury and/or property damage due to incorrect or improper transport of the pump

In the event of incorrect or improper transport, the pump can fall down, be damaged or injure persons.

- Use suitable auxiliary means if necessary (carrying strap, lifting gear, etc.).
 - Where appropriate, wear suitable personal protective equipment (e.g., safety shoes, safety gloves).
-



CAUTION

Risk of injury from sharp edges on the packaging

There is a risk of injury from cutting on the sharp edges when grabbing corners or when opening the packaging.

- Where appropriate, wear suitable personal protective equipment (e.g., safety shoes, safety gloves).
-

- Transport the pump in the original packaging to the installation location.
- Keep the original packaging of the pump (e.g. for later storage).
- Inspect the pump for transport damage after receiving it.
- Document any transport damage that has occurred.

→ Remove any transport safeguards on the pump prior to commissioning.

Parameter

Parameter	Value
Storage temperature [°C]	+ 5 to + 40
Transport temperature [°C]	- 10 to + 60
Permissible humidity (non-condensing) [%]	30 to 85

Tab. 11: Transport parameters and storage parameters



NOTICE

Prior to commissioning, make sure that the pump has reached the ambient temperature (3 *Technical data* [▶ 12]).

6 Installation and connection

Only install the pumps in accordance with the operating parameters and conditions described in Chapter 3 *Technical data* [▶ 12].

- Observe the safety instructions (see Chapter 2 *Safety* [▶ 6]).



DANGER

Risk of dangerous gas mixtures during pump operation

Depending on the medium being transferred, breakage of the media-contacting components can result in a dangerous mixture if the medium mixes with the air in the compressor housing or the surroundings.

- Before using a medium, check the compatibility of the media-contacting components (see 3 *Technical data* [▶ 12]) with the medium.

Heater

- i** As the insulation material of the heating elements is hygroscopic, it may be necessary, depending on the version and type of storage (e.g. high air humidity), to check the insulation resistance with a suitable measuring device (megohm-meter with 500V DC measuring voltage, $R_{min} = 5M\Omega$) before connecting the heating element. If necessary, dry out the heating element at elevated temperature (at about 120°C in the oven, time: several hours, until acceptable measured values are obtained).

6.1 Installing the pump

- Store the pump at the installation location to allow it to adapt to the ambient temperature before installation (condensation must not be allowed to form).

Mounting dimensions

- For mounting dimensions, see the following illustrations:

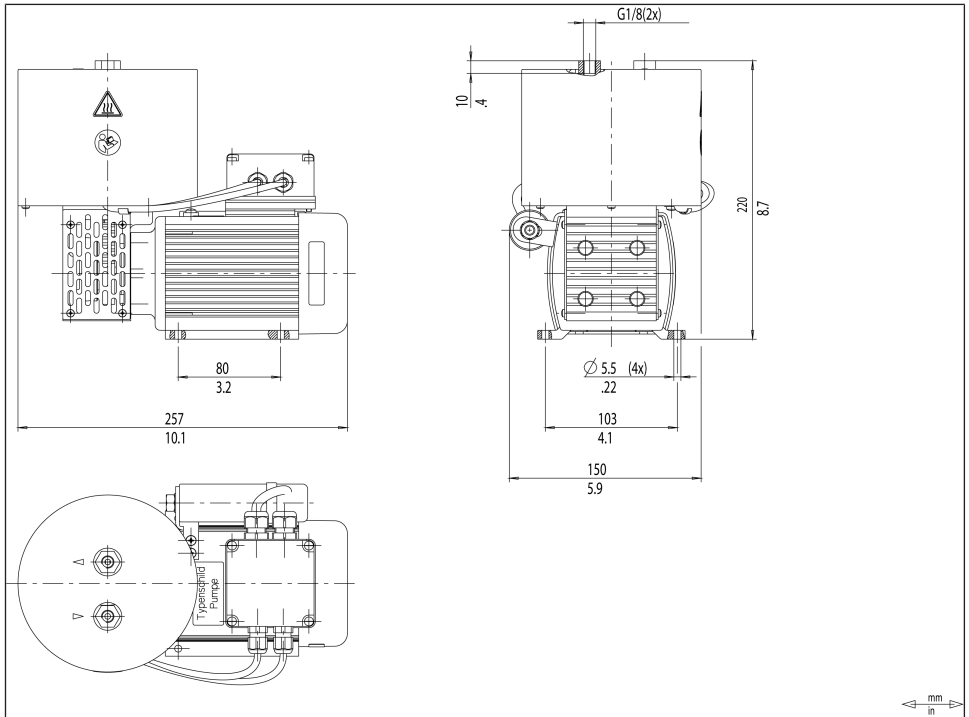

Fig. 4: Mounting dimensions N024.11

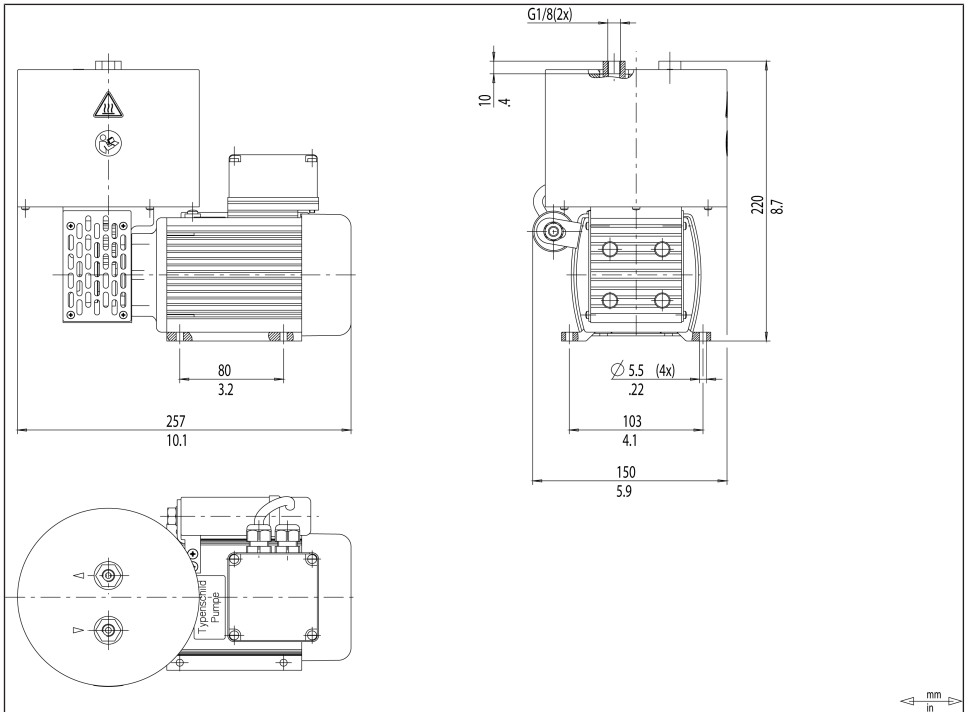

Fig. 5: Mounting dimensions N024.16

Cooling air supply



WARNING

Danger of burning on hot surfaces

Hot surfaces could occur if the pump overheats.

→ When installing the pump, make sure that sufficient cooling air in-feed and discharge is ensured.

Proximity to hot pump parts

→ During installation, make sure that no combustible or thermally deformable objects are positioned in proximity to hot pump parts (head, motor).

Installation location

→ Make sure that the installation location is dry and that the pump is protected from rain, spray water, splash water, dripping water and other contaminants.

- Make sure the installation location allows access for servicing.
 - i** The IP protection class of the pump motor is specified on the type plate.
 - Install the pump at the highest point in the system to prevent condensate from collecting in the pump head.
 - Protect the pump from dust.
 - Protect the pump from vibration and impact.
- Installation position
- The pump can be operated in any installation position. Use metal screws to fasten the pump at the indicated attachment points. Observe the specifications of the selected fasteners.

6.2 Electrical connection



DANGER

Danger to life from electric shock

- Only have the pump connected by an authorized specialist.
- Only have the pump connected if the power supply is disconnected.

-
- When connecting to a power source, observe the applicable standards, regulations, directives, and technical standards.
 - The pumps have been developed, manufactured and tested for S1 operation. Additional operating modes can be made possible on a project-specific basis following consultation with KNF Customer Service.
 - Install a device for separating the pump motor from the electrical grid in the electrical installation (e.g. in accordance with EN 60335-1).

- Protect the pump motors, e.g., in accordance with EN 60204-1 (overcurrent protection, overload protection).
- i** Refer to the type plate for the maximum current consumption of the pump.
- Install an Emergency Off device such that it is not possible for there to be an automatic restart or for hazardous situations to persons and property to occur.
- Install the pumps in such a way that it is not possible to touch electrically live parts (electrical connection).

Fastening the
connection ca-
bles

- Fasten the connection cables so that
 - the cables do not come into contact with movable or hot parts.
 - the cables cannot be worn or damaged on sharp corners or edges
 - no tensile and pressure forces are exerted on the connection point of the cables (strain relief)

Connecting the pump

1. Confirm that the power supply meets the parameters listed on the pump type plate. Refer to the pump type plate for the rated current draw.
 - i** The supply voltage may deviate by maximum +10% or – 10% from the values on the type plate.

Electrical connection of the .16 versions (pumps with temperature-resistant heads)

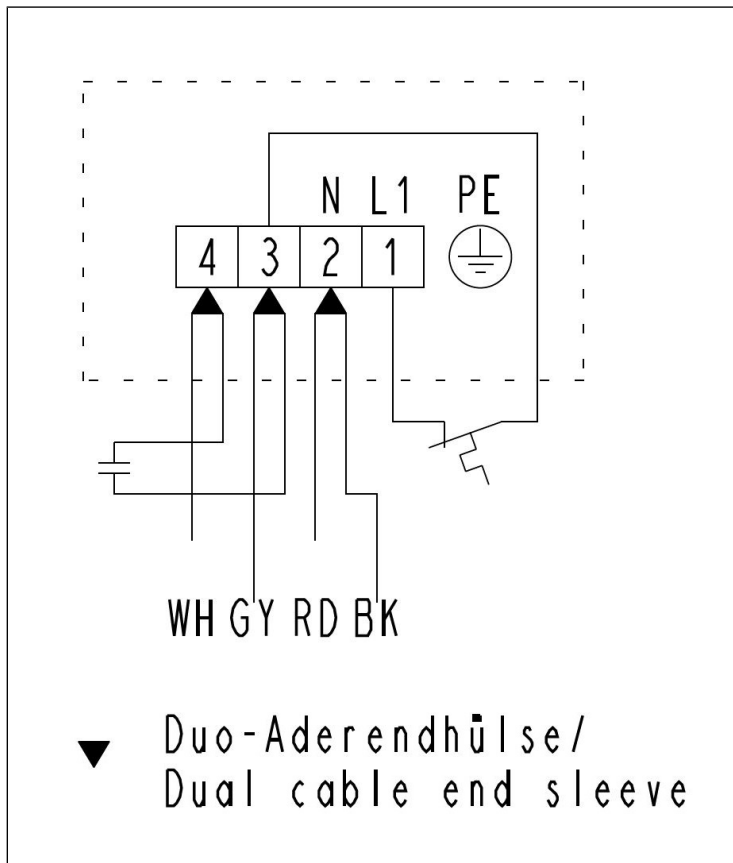

Fig.6: Electrical connection of .16 version

1. Loosen the four screws and remove the terminal box cover of the motor.
2. Pull the power cable into the housing through the free cable gland of the electrical connection.
3. Connect the protective earth conductor to the earthing terminal.
4. Connect the power cable to the L 1 and N connections of the terminal blocks (see Fig. 6).

5. Replace the terminal box cover of the motor and screw it tight.
Ensure that the cover seal is properly seated!

Electrical connection of .11 versions (pumps with heated heads, thermostatically controlled)

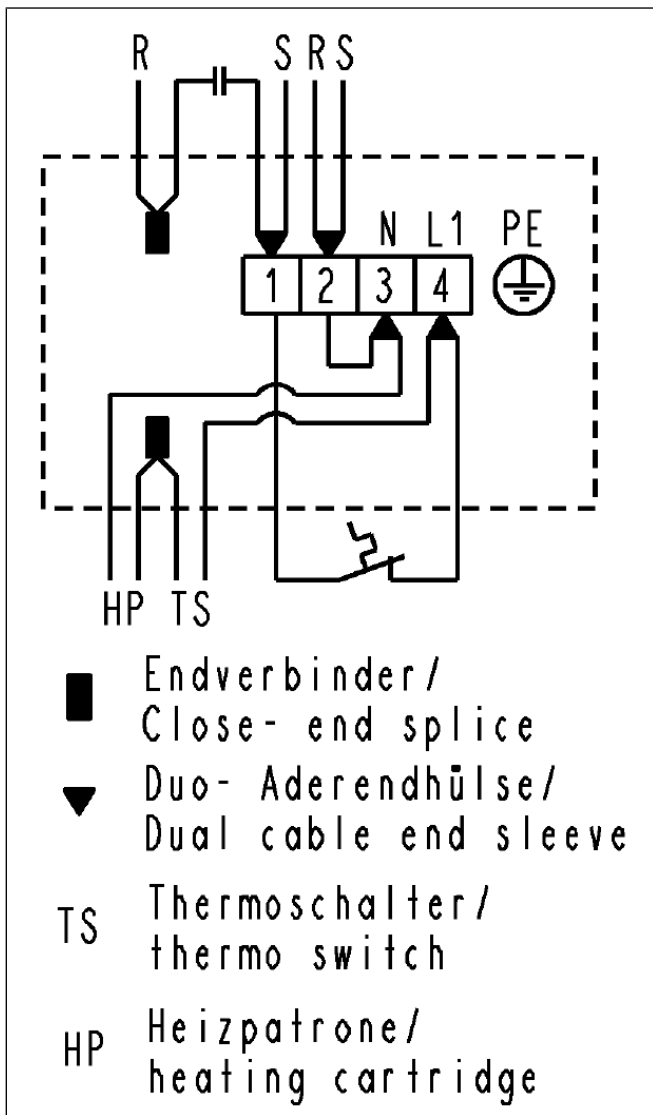

Fig.7: Electrical connection of .11 version

1. Refer to the motor and heater type plates for the electrical data.
2. Loosen the four screws and remove the terminal box cover of the motor.
3. Pull the power cable into the housing through the free cable gland of the electrical connection.
4. Connect the protective earth conductor to the earthing terminal.
5. Connect the power cable to the L 1 and N connections of the terminal blocks (see Fig. 7).
6. Replace the terminal box cover of the motor and screw it tight.
Ensure that the cover seal is properly seated!

6.3 Pneumatic connection



Personal injury or property damage through ejected plugs

If not removed, the plugs on the outlet of the pump can be ejected during operation by the resulting overpressure.

→ Remove the plugs during installation.

→ Wear appropriate personal protective equipment.

-
- | | |
|----------------------|--|
| Connected components | → Only connect components to the pump that are designed for the pneumatic data and thermal requirements of the pump. (see Chapter 3 <i>Technical data</i> [▶ 12]). |
| Pump discharge | → Discharge the possibly hot pump discharge at the pneumatic outlet of the pump safely (with regard to medium and noise). |
| Decoupling | → KNF recommends mechanically decoupling the pump from the pipe system, e.g., through the use of flexible hoses or pipes. In this way it is possible to prevent the transfer of possible pump vibrations and noises to the system. |

Connecting the pump

i A marking on the pump head indicates the flow direction.



CAUTION

Risk of injury due to mixing up inlet and outlet

Mixing up the inlet and outlet may cause breakage of components connected at the inlet and outlet.

→ Observe the marking of inlet and outlet on the pump head.

-
1. Remove the protective plugs from the hose connection threads.
 2. Connect the suction line and the pressure line (for mounting dimensions, see Chapter 3 *Technical data* [▶ 12]).
 3. Lay the suction line and pressure line with a descent so that no condensate can run into the pump.

i Pneumatic noises can be reduced or dissipated by using a silencer.

7 Operation

7.1 General



WARNING

Risk of burns from hot pump parts and/or hot medium

Some pump parts may be hot during or after operation of the pump.

- Allow the pump to cool after operation.
 - Take protective measures to protect against touching hot parts.
-



WARNING

Personal injury and damage to the pump through automatic start

If pump operation is interrupted by the thermal switch due to overheating, the pumps start automatically after they have cooled.

- Ensure that no dangerous situations can arise as a result.
-



WARNING

Injury to eyes

Coming too close to the inlet/outlet of the pump may result in injury to the eyes due to the present vacuum/operating pressure.

- Do not look into the pump inlet/outlet during operation.
-

- Only operate the pumps under the operating parameters and operating conditions as described in Chapter 3 *Technical data* [▶ 12].

- Ensure the proper use of the pumps (See Chapter 2.6.1 *Proper use* [▶ 9]).
 - Rule out the possibility of foreseeable misuse of the pumps (see chapter 2.6.2 *Foreseeable misuse* [▶ 9]).
 - Observe the safety instructions (Chapter 2 *Safety* [▶ 6]).
 - The pumps are built-in devices. Before they are commissioned, it must be ensured that the machines or systems into which the pumps are installed comply with the relevant provisions.
-



Risk of bursting of pump head due to excessive pressure increase

- Do not exceed the maximum permissible operating pressure (see 3 *Technical data* [▶ 12]).
 - Monitor the pressure during operation.
 - If the pressure exceeds the maximum permissible operating pressure of the pump: Switch the pump off immediately and remedy the malfunction (see Chapter 10 *Störung beheben* [▶ 43]).
 - Only throttle or regulate the air or gas quantity on the inlet line to prevent the maximum permissible operating pressure from being exceeded.
 - If the air quantity or gas quantity on the outlet line is throttled or regulated, make sure that the maximum permissible operating pressure at the pump is not exceeded.
 - Ensure that the pump outlet is not closed or restricted.
-

**NOTICE**

Excessive pressure, with all of the associated hazards, can be prevented by means of a bypass line with a pressure relief valve between the outlet and inlet of the pump. Further information is available from KNF Customer Service (contact data: see www.knf.com).

**WARNING**

Risk of dangerous gas mixtures during pump operation if diaphragm breaks
If the diaphragm should break, the medium will mix with the air in the compressor housing or in the surroundings.

- Stop pump immediately.
- Replace the diaphragm prior to further operation (see Chapter 8 *Servicing* [▶ 34]).

**WARNING**

Personal injury and damage to the pump through automatic start

If pump operation is interrupted by the thermal switch due to overheating, the pumps start automatically after they have cooled.

- Ensure that no dangerous situations can arise as a result.



Risk of burns from hot pump parts

When using hot media, the pneumatic supply and discharge lines of the pump heat up, as does the pump head.

→ Avoid touching hot parts.



NOTICE

Operation with open gas connection at the inlet can result in contaminants and objects being drawn in.

- Pump standstill → When the pump is at a standstill, establish normal atmospheric pressure in the lines.
- Vapors as medium The service life of the diaphragm can be extended, if no condensate forms in the pump. Therefore:
- Perform any work with saturated or near-saturated vapors only with a warm pump.
 - KNF recommends: When pumping corrosive media, flush the pump before switching off (see Chapter 8.2.1 *Flushing the pump* [▶ 35]) to extend the service life of the diaphragm.

7.2 Information on switching the pump on and off

Switching on the pump



NOTICE

The pump must not be started up against pressure or vacuum during switch-on. This also applies after a brief power interruption during operation. If a pump starts up against pressure or vacuum, the pump may block, causing the thermal switch to respond and the pump to switch off.

-
- Ensure that normal atmospheric pressure is present in the lines when switching on.

Switching off/decommissioning the pump

- Establish normal atmospheric pressure in the lines (relieve pump pneumatically).
- | | |
|---------------------|---|
| Recommissioning | → Before recommissioning, observe the applicable standards, guidelines, regulations and technical standards at the electrical connection. |
| Inspecting the pump | → Inspect the pump periodically for external damage or leakage. |

8 Servicing



NOTICE

Servicing the pump

Damage to the pumps can result from failure to observe the applicable legal regulations and procedures for the location or intervention by untrained or uninstructed personnel.

- Servicing may only be performed according to the legal regulations (e.g. work safety, environmental protection) and provisions.
 - Servicing may only be performed by specialized personnel or trained and instructed personnel.
-

8.1 Servicing schedule

Component	Servicing interval
Pump	<ul style="list-style-type: none"> → Perform periodic inspections for external damage or leakage. → Periodically check for noticeable changes to noises and vibrations.
Gas connections	<ul style="list-style-type: none"> → Perform periodic inspections for external damage or leakage.
Diaphragms and valves	<ul style="list-style-type: none"> → Replace if the pressure or flow rate of the pump changes for no apparent reason. → At the latest, replace when the performance decreases.

Tab. 12:

8.2 Cleaning

8.2.1 Flushing the pump

When transferring dangerous and environmentally hazardous media, KNF recommends flushing the pump with air at atmospheric pressure for a few minutes prior to switch-off (if necessary for safety reasons: with an inert gas) to extend the service life of the diaphragm.

→ Discharge the media safely.

8.2.2 Cleaning the pump

Requirements → Pump disconnected from mains and voltage-free

**CAUTION**

Risk of burns from hot pump parts

The pump head or motor may still be hot after operation of the pump.

- Allow the pump to cool after operation.

**WARNING**

Health hazard due to dangerous substances in the pump

Depending on the medium being transferred, caustic burns or poisoning is possible.

- Wear protective equipment if necessary, e.g., protective gloves, goggles.
- Clean the pump with suitable measures.

**NOTICE**

During cleaning work, ensure that no fluids enter the interior of the housing.

- Only clean the pump with a dry wiping cloth. When cleaning, use no solvents if possible as these can affect the plastic parts.
- Only use solvents during cleaning if head materials are not corroded (ensure resistance of the material).
- If compressed air is available, blow out the components.

8.3 Replacing diaphragm and valves

- Requirements
- Disconnect the motor from the power supply and ensure that the motor is voltage-free.
 - Make sure that there are no hazardous substances in the pump.
 - Remove the hoses from the inlet and outlet.



Risk of burns when using hot media
When using hot media, the pump's media-conveying components become hot. Touching these hot parts can cause burns.

- Only carry out work on the pump after the pump head has cooled down.

Spare parts

Spare part*	Item designation	Quantity
Diaphragm	(2)	1 per pump head
Valve	(11)	2 per pump head
O-ring	(10)	2 per pump head

Tab. 13: *acc. to 9 Spare parts [► 42]

Quantity	Tool/material
1	Size 1 Phillips screwdriver
1	Adjustable face spanner wrench for nuts with two holes or KNF wrench for retainer plate (see Accessories)
1	Felt-tip pen
1	Sharp knife
1	Phillips screwdriver (only .11 versions)
1	Open-end or socket wrench, 8 mm

Tab. 14:

- Information on the procedure
- Always replace diaphragm, valve plates and O-rings together to maintain the performance of the pump.

**WARNING**

Health hazard due to dangerous substances in the pump

Depending on the medium being transferred, caustic burns or poisoning is possible.

- Wear protective equipment if necessary, e.g., protective gloves, goggles.
- Clean the pump with suitable measures.

Perform diaphragm and valve replacement in the following order:

- a.) Initial steps
- b.) Removing the pump head
- c.) Changing the diaphragm
- d.) Changing valves and sealing rings
- e.) Mounting the pump head
- f.) Final steps

- 1 Support ring
- 2 Diaphragm
- 3 Intermediate plate
- 4 Head plate
- 5 Disk springs
- 6 Cap nut
- 7 Retainer plate
- 8 Conrod plate
- 9 Connection rod extension
- 10 O-ring
- 11 Valve

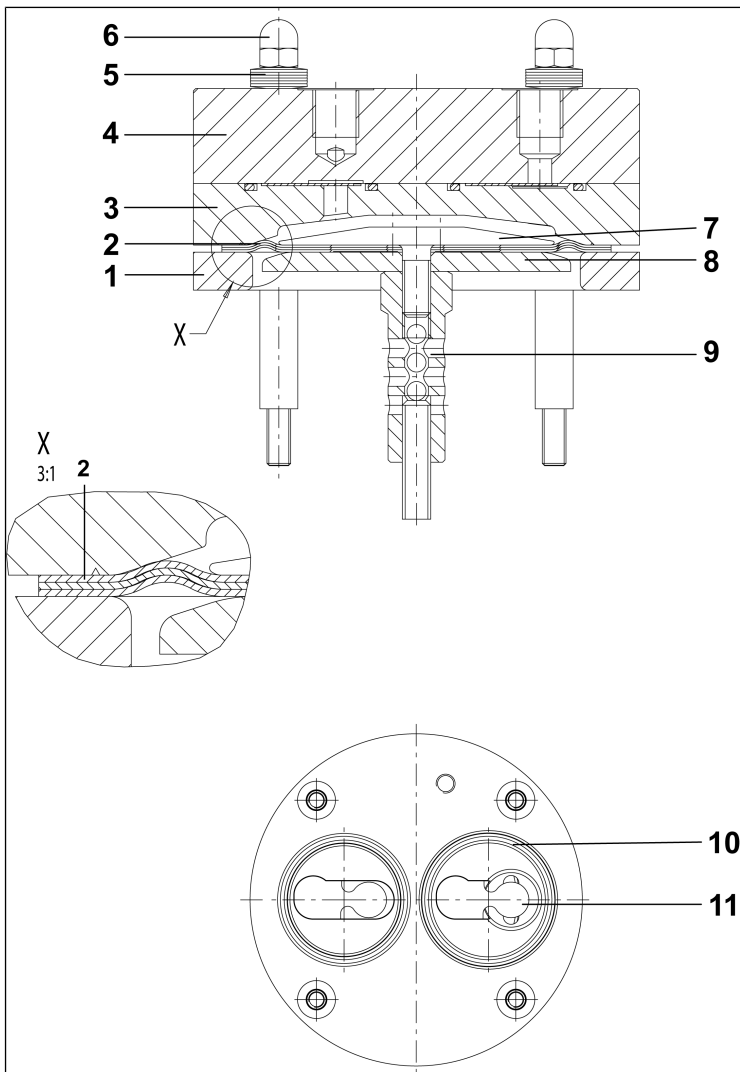

Fig.8: Pump head (symbolic)

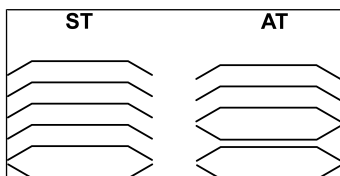

Fig.9: Location of disk springs

a.) Initial steps

1. Loosen the screws on the underside of the head insulation and remove it upwards.
2. Only .11 versions (pumps with thermostatically controlled head heating):
Loosen the strain relief on the underside of the head insulation.

b.) Removing the pump head

- i** For pumps with heating cartridge (.11 versions):
The heating cartridge remains mounted in the head plate.
1. Use a felt-tip pen to draw a continuous line on the support ring (1), intermediate plate (3), and head plate (4).
This helps to ensure that the parts are installed correctly during subsequent assembly.
 2. Loosen the cap nuts (6) and remove them together with the disk springs (5).
 - i** The disk springs are installed to maintain the tensile force of the wave diaphragm over the temperature range of the pump.
 3. Remove the head plate (4).
 4. Remove the intermediate plate (3).
 5. Remove the valve plates (11) and O-rings (10) from the intermediate plate (3).

c.) Diaphragm replacement

1. Cut through the diaphragm (2) all the way around (cutting out the retainer plate (7) – facilitates removal).
2. Loosen the retainer plate (7) counterclockwise with a wrench for retainer plate. Apply the open-end wrench to counterhold the connection rod extension (9).
 - i** Make sure that the spacer does not slip out under the conrod plate (8).
3. Remove the diaphragm (2).
4. Check the intermediate plate and head plate for cleanliness and clean if necessary. Replace these parts in the event of unevenness, scratches or corrosion.

5. Push the new diaphragm (2) onto the threaded bolts of the retainer plate (7).
6. Screw the retainer plate (7) with diaphragm (2) into the connection rod extension (9) and tighten it firmly with the wrench for retainer plate. (Tightening torque: 8 Nm).

d.) Changing valves and sealing rings

1. Check the valve seats, intermediate plate (3) and head plate (4) for cleanliness. replace these parts in the event of unevenness, scratches or corrosion.
2. Place the intermediate plate (3) on the support ring (1) according to the felt-tip pen marking.
3. Insert the new valves (11) into the valve seats of the intermediate plate.

i The valves are identical for the pressure and suction side; the position of the valves is specified by the shape of the valve seats.

4. Insert the new O-rings (10) in the intermediate plate (3).

e.) Mounting the pump head

1. Place the head plate (4) on the intermediate plate (3) according to the felt-tip pen marking.
2. Put on the disk springs (5) (for location, see Fig. 9).
3. Put on the cap nuts (6) and tighten them (tightening torque: 5 Nm).

f.) Final steps

1. Mount the head insulation.
2. Only .11 versions (pumps with thermostatically controlled head heating):
Slide the protective tube into the hole in the base plate.
Tighten the strain relief on the underside of the head insulation.
3. Check the pump head and pneumatic connections for leaks.
4. Re-connect the pump to the power supply.

9 Spare parts

Spare part set

A spare part set consists of:

Spare part	Item number*	Number per pump head
Diaphragm	(2)	1
Valve	(11)	2
O-ring	(10)	2
Disk spring	(5)	24

Tab. 15: Spare parts

*see 8.3 Replacing diaphragm and valves [▶ 37]

Spare part set	Order number
N024	032524

Tab. 16: Spare part set

10 Troubleshooting



Danger: electric shock can be life-threatening.

- All work on the pump may only be performed by an authorized specialist.
- Before working on the pump: Disconnect the pump from the power supply.
- Check and ensure that no voltage is present.

-
- Allow the pump to cool before troubleshooting.
 - Check the pump (see following tables).

Pump not delivering	
Cause	Troubleshooting
Pump is not connected to the electrical power supply.	→ Connect the pump to electrical power.
No voltage in the electrical power supply.	→ Check the circuit breaker for the room and switch it on if necessary.
Pneumatic connections or lines are blocked.	→ Check the connections and lines. → Remove the blockage.
External valve is closed or filter clogged.	→ Check external valves and filters.
Condensate has collected in the pump head.	→ Separate the source of the condensate from the pump. → Flush the pump with air at atmospheric pressure for a few minutes (if necessary for safety reasons: with an inert gas). → Install the pump at the highest location in the system.
Thermal switch of the motor has tripped.	→ Disconnect the pump from electrical mains. → Allow the pump to cool down. → Determine the cause of the overheating and eliminate the cause.
Diaphragm and valves are worn or defective.	→ Replace diaphragm and valves (see Chapter 8 Servicing [▶ 34]).

Tab. 17:

Flow rate, pressure or vacuum too low	
The pump does not reach the performance stated in the technical data or data sheet.	
Cause	Troubleshooting
Condensate has collected in the pump head.	<ul style="list-style-type: none"> → Separate the source of the condensate from the pump. → Flush the pump with air at atmospheric pressure for a few minutes (if necessary for safety reasons: with an inert gas). → Install the pump at the highest location in the system.
There is overpressure on the pressure side and at the same time vacuum or pressure above atmospheric pressure on the suction side.	<ul style="list-style-type: none"> → Change the pneumatic conditions.
Pneumatic lines or connection parts have insufficient cross-sections or are constricted.	<ul style="list-style-type: none"> → Disconnect the pump from the system to determine the output values. → Eliminate any constriction (e.g. valve). → Use lines or connection parts with a larger cross-section if necessary.
Leaks occur at pneumatic connections, lines or pump head.	<ul style="list-style-type: none"> → Eliminate the leaks.
Pneumatic connections or lines are partially or completely blocked.	<ul style="list-style-type: none"> → Check the pneumatic connections and lines. → Remove any parts or particles that are causing blockages.
Head parts are soiled.	<ul style="list-style-type: none"> → Clean the head components.
Working diaphragm broken	<ul style="list-style-type: none"> → Stop the pump immediately. → Change the diaphragm (see 8 Servicing [▶ 34]).
Diaphragm and valves are worn or defective.	<ul style="list-style-type: none"> → Replace diaphragm and valves (see Chapter 8 Servicing [▶ 34]).

Tab. 18:

Pump exhibiting changed running noises and vibrations	
Cause	Troubleshooting
Pump bearing worn or defective.	→ Determine the cause. → Contact KNF Customer Service.

Tab.19:

Pump head is not heated*	
Cause	Troubleshooting
Cable connection in the terminal box (.11 versions) has no contact.	→ Connect the cable (see Fig. 7).
No voltage in the power supply	→ Check the power supply.
Temperature switch defective	→ Change the temperature switch**

Tab.20: *Only .11 versions

**If you have any questions, contact KNF Customer Service.

Fault cannot be rectified

If you are unable to identify any of the specified causes, send the pump to KNF Customer Service (contact data: see www.knf.com).

1. Flush the pump with air for a few minutes (if necessary for safety reasons: with inert gas) at atmospheric pressure to free the pump head of dangerous or aggressive gases (see Chapter 8.2.1 *Flushing the pump* [▶ 35]).
2. Remove the pump.
3. Clean the pump (see Chapter 8.2.2 *Cleaning the pump* [▶ 35]).
4. Send the pump together with completed Health and Safety Clearance and Decontamination Form to KNF, specifying the pumped medium.

11 Returns

Preparing for return

1. Flush the pump with air for a few minutes (if necessary for safety reasons: with inert gas) at atmospheric pressure to free the pump head of dangerous or aggressive gases (see Chapter 8.2.1 *Flushing the pump* [▶ 35]).

i Please contact your KNF sales partner if the pump cannot be flushed due to damage.
2. Remove the pump.
3. Clean the pump (see Chapter 8.2.2 *Cleaning the pump* [▶ 35]).
4. Send the pump together with the completed Health and Safety Clearance and Decontamination Form to KNF, stating the nature of the transferred medium.
5. Pack the device securely to prevent further damage to the product. If necessary, request original packaging for a fee.

Returns

KNF shall undertake to repair the pump only under the condition that the customer presents a certificate regarding the medium that is pumped and the cleaning of the pump. In this case too, old devices can be returned. Please follow the instructions at [knf.com/repairs here](https://knf.com/repairs).

Contact your KNF sales partner directly if you require additional support for your return service.

KNF Neuberger GmbH
Alter Weg 3
79112 Freiburg
Germany
Tel. +49 (0)7664/5909-0

E-mail: info.de@knf.com
www.knf.com

KNF worldwide

You can find our local KNF partners at: www.knf.com

