

DIAPHRAGM LIQUID PUMP EXPLOSION-PROOF VERSION NF 1.300 EX

Pump: II 2G EX h IIB T5 Gb / Motor: II 2G Ex db IIC T4 Gb

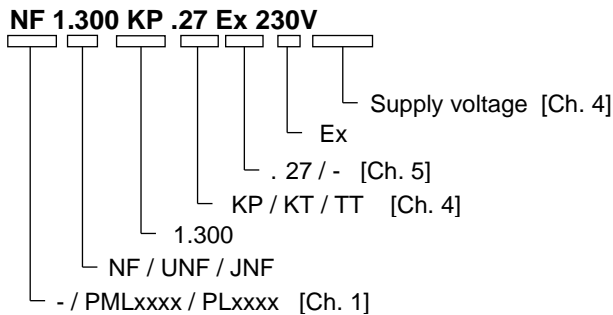

Operating and Installation Instructions

Read and observe these Operating and Installation Instructions!

For pumps with a drive motor: be sure to also read and observe the drive motor's Operating and Installation Instructions, which must be considered part of the pump's Operating and Installation Instructions.

Due to separate certification of the mechanical (pump) and electric (drive motor) parts, the device has two rating plates. Each rating plate describes only the part of the device to which it is applied.

An additional letter prefixing the NF model code is a country-specific designation, with no technical relevance.

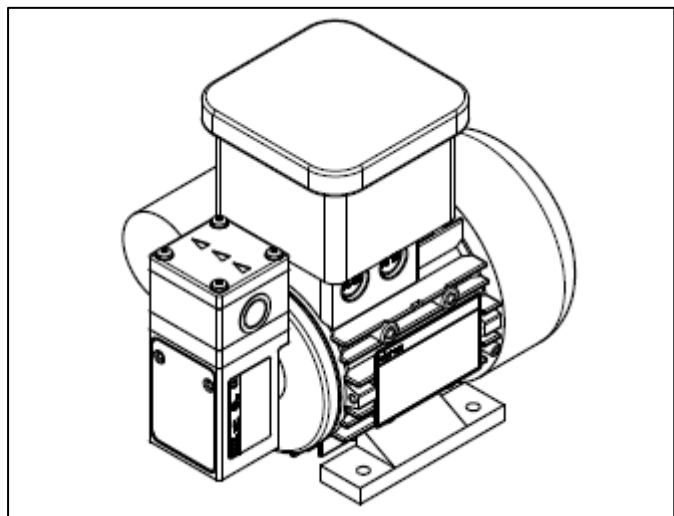

TPS 19 ATEX 039495 0007 X

KNF Flodos AG
Wassermatte 2
6210 Sursee, Switzerland
Tel +41 (0)41 925 00 25
Fax +41 (0)41 925 00 35
www.knf.com
info.flodos@knf.com

Contents

Page

1. About this document.....	2
2. Use	3
3. Safety	7
4. Technical data	10
5. Assembly and function	12
6. Installation and connection.....	13
7. Operation.....	18
8. Servicing.....	20
9. Troubleshooting.....	25
10. Return of the pump.....	28

1. About this document

1.1. Use of the Operating and Installation Instructions

The Operating and Installation Instructions are part of the pump.

→ Forward the Operating and Installation Instructions to any subsequent owners of the pump.

Project pumps Customer-specific project pumps (pump models which begin with "PL" or "PML") may differ from the Operating and Installation Instructions.

→ In the case of project pumps, take note of any additionally agreed specifications.

Drive motor The Operating and Installation Instructions apply to the pump without drive motor.

→ Observe also the drive motor's Operating and Installation Instructions.

1.2. Symbols and markings

Warning



WARNING

This symbol indicates a potential danger.

It also indicates the possible consequences of failure to observe the warning. The signal word (e.g. "Warning") indicates the level of danger.

→ Here you will see actions for avoiding the danger and potential consequences.

Danger levels

Signal word	Meaning	Consequences if not observed
DANGER	warns of immediate danger	Consequences include death or serious injuries and/or serious property damage.
WARNING	warns of potential danger	Death or serious injuries and/or serious damage to property are possible.
CAUTION	warns of a potentially dangerous situation	Minor injuries or damage to property are possible.

Tab. 1

Other information and symbols

→ This indicates an activity (step) that must be carried out.

1. This indicates the first step of an activity to be carried out. Any additional steps required are numbered consecutively.



This symbol indicates important information.

2. Use

2.1. Intended use

The pumps are intended for transferring and metering liquids.

Owner's responsibility

Operating parameters and conditions

Only install and operate the pumps under the operating parameters and conditions described in Chapter 4, Technical data, and Section 2.3, Using the pump in a potentially explosive atmosphere.

Only complete pumps may be taken into service.

Requirements for transferred medium

Before transferring or metering a medium, check whether the medium can be transferred danger-free in the specific application case.

Before using a medium, check the compatibility of the materials of the pump head, pump housing, diaphragm and valves with the medium.

The temperature of the medium must lie within the permissible temperature range (see Chapter 4).

The transferred medium should not contain particles as these can prevent the pump from working correctly. If this cannot be guaranteed, a filter < 100 µm with sufficiently large filter area must be used upstream of the pump.

2.2. Improper use

For special modifications outside the standard technical specifications, please contact your KNF technical adviser.

2.3. Using the pump in a potentially explosive atmosphere

Only pumps of the appropriate Equipment Category and temperature class must be operated in potentially explosive atmospheres (areas).

Such pumps have the following explosion prevention and protection markings:

Marking	Description
	Symbol for explosion-proof pumps
II	Equipment Group (see Section 2.4.1)
2 G	Equipment Category (see Section 2.4.2)
h	Type of Protection (see Section 2.4.6)
II A and II B	Explosion Groups (see Section 2.4.4)
T5	Temperature Class (see Section 2.4.3)
Gb	EPL (Equipment Protection Level)

Tab. 2

The explosion prevention and protection markings can also be found in the following location:

- Rating Plate

Drive motor

The drive motor of the pump must have at least the same explosion prevention and protection as the pump itself.

2.4. Explanation of explosion prevention and protection markings

2.4.1. Equipment groups

- Equipment Group I Equipment Group 1 applies to equipment for use in the underground operations of mines and any of their surface installations that may be at risk from methane and/or combustible dust.
- Equipment Group II Equipment Group II applies to equipment for use in other areas which may be at risk from explosive atmosphere.

2.4.2. Equipment Categories for gas

The Equipment Category describes the frequency and duration of occurrence of explosive atmospheres in an area.

Equipment Category	Description*	Constructional safety
1	Areas in which hazardous explosive atmospheres are likely to occur continuously, for long periods or frequently.	Very high
2	Areas in which hazardous explosive atmospheres are likely to occur occasionally.	High
3	Areas in which it is unlikely that hazardous explosive atmospheres will occur, or if they do occur, are only likely to do so infrequently and for a short time.	Normal

Tab. 3

*in accordance with EN 1127-1

2.4.3. Temperature classes

- Maximum surface temperature The maximum surface temperature is the highest temperature reached by one of the pump's surfaces under worst case conditions.
- Ignition temperature The maximum surface temperature of the pump must always be lower than the lowest ignition temperature of the gas or vapour/air mixture in which it is operated.
- Temperature class The maximum surface temperature depends on the design of the pump, and is shown as a temperature class.

Temperature class	Max. surface temperature [°C]	Ignition temperature [°C]
T1	≤ 450	> 450
T2	≤ 300	> 300
T3	≤ 200	> 200
T4	≤ 135	> 135
T5	≤ 100	> 100
T6	≤ 85	> 85

Tab. 4

2.4.4. Explosion Groups

Flammable gases and vapours are classified into explosion groups (I, IIA, IIB and IIC) and temperature classes. Tab. 5 shows the classifications of the most common flammable gases and vapours.

	T1	T2	T3	T4	T5	T6
I	Methane	–	–	–	–	–
IIA	Acetone Ethane Ethyl acetate Ammonia Ethyl chloride Benzene Acetic acid Carbon monoxide Methane Methanol Methyl chloride Naphthalene Phenol Propane Toluene	i-amyl acetate n-butane n-butyl alcohol Cyclohexanone 1,2 dichloroethane Acetic anhydride	Benzene Diesel fuel Aviation turbine fuel Heating oils n-hexane	Acetaldehyde	–	–
IIB	Town gas	Ethylene Ethyl alcohol	Hydrogen sulphide	Ethyl ether	–	–
IIC	Hydrogen	Acetylene	–	–	–	Carbon disulphide

Tab. 5

The classification of gases and vapours into groups according to explosion group and temperature class applies to both the medium to be transferred and the environment of the pump.

Transferred medium

The pumps must only be used to transfer gases and vapours that are either not explosive or belong to explosion groups II A or II B and temperature class T4 (or lower) (shaded area in Tab. 5).

Pump environment

The pumps must only be used in an environment containing an atmosphere that is either not explosive or belongs to explosion groups II A or II B and temperature class T4 (or lower) (shaded area in Tab. 5).

2.4.5. Types of protection

Designation	Description
bh	Protection by Control of Ignition Source
h	Constructional safety
kh	Liquid encapsulation
d	Pressureproof enclosure
e	Increased safety
i	Intrinsic safety
p	Pressurisation
m	Encapsulation
o	Oil immersion
q	Powder filling
nA	Non-sparking
nC	Several meanings
nR	Vapour proof housing
nL	Energy-limited (varies between North America and Europe)
nP	Simplified pressurisation



Tab. 6

3. Safety

i Observe the safety precautions in Chapters 6. Installation and connection, and 7. Operation.

The pumps are built according to the generally recognised rules of technology and in accordance with the pertinent occupational safety and accident prevention regulations. Nevertheless, dangers may occur during their use which may lead to injuries to the user or others, or to damage to the pump or other property.

Only use the pumps when they are in a good technical and proper working order, in accordance with their intended use, observing the safety advice within the Operating and Installation Instructions, at all times.

Personnel	<p>Make sure that only trained and instructed personnel or specially trained personnel work on the pumps. This especially applies to assembly, connection and servicing work.</p> <p>Make sure that all personnel have read and understood the Operating and Installation Instructions, and in particular the "Safety" chapter.</p>
Working in a safety-conscious manner	Observe the accident prevention and safety regulations when performing any work on the pump and during operation.
Handling dangerous medium	When transferring dangerous medium, observe the safety regulations for handling such medium.
Notes	Always ensure adherence to all information stickers on the pumps, such as flow direction arrows and rating plates, and keep stickers in legible condition.
Environmental protection	All replacement parts should be properly stored and disposed of in accordance with the applicable environmental protection regulations. Ensure adherence to the pertinent national and international regulations. This especially applies to parts contaminated with toxic substances.
Disposal	<p>Dispose of all packaging in an environmentally-appropriate manner. The packaging materials are recyclable. </p> <p>Dispose of end-of-life equipment in an environmentally friendly manner. Use appropriate waste collection systems for the disposal of end-of-life equipment. Used pumps contain valuable recyclable materials. </p>
EU directives/standards	For the purposes of the Machinery Directive 2006/42/EC, pumps are "partly completed machinery", and are therefore to be regarded as not ready for use. Partly completed machinery may not be commissioned until such time as it has been determined that the machine in which the partly completed machinery is to be assembled conforms to the provisions of the Machinery Directive 2006/42/EC. The essential requirements of Annex I of Directive 2006/42/EC (general principles) are applied and observed.

EU directives/standards	The pumps comply with Directive 2014/34/EU concerning equipment and protective systems for intended use in explosive atmospheres, and with the standards Normen ISO 80079-36 and ISO 80079-37 for ex areas.
EU directives/standards	<p>The "Directives for the prevention of risks from explosive atmospheres with a collection of examples – explosion prevention and protection directives – (EX-RL)" should be observed when classifying a pump environment in an explosion-proof area.</p> <p>In special cases or where there is doubt when defining potentially explosive atmospheres, notify the supervisory authorities and ask them to decide.</p>
Customer service and repairs	<p>All repairs to the pump(s) must be carried out by the relevant KNF Customer Service team.</p> <p>Only use genuine parts from KNF for servicing work.</p>

Safety concept

Risk analysis	A risk analysis was carried out in accordance with EN 1127-1.
---------------	---

Ignition sources

Heating of head	If the pump compresses against the maximum permissible operating pressure, the temperature of the head will not exceed the maximum surface temperature because the head is able to transfer heat to its environment. The pump's environment must therefore be adequately ventilated.
Electrostatic charge	The projected surface area of the non-conductive parts which may become electrostatically charged is less than 100cm ² . The total surface area of electrically insulated metal disks is very small, in addition to which the screw heads are countersunk in the pump head. As a result there should be no risk of ignition from the electrostatically chargeable parts.
Mechanically generated sparks	<p>As a result of the material used inside the pump, the possibility that critical material combinations may come into contact is excluded. In addition, these are mounted pumps, which should preferably be installed in housings and are made of plastic.</p> <p>The nuts and bolts used are made of stainless steel, so contact with critical materials is unlikely.</p>

Rupturing of diaphragm	<p>Rupturing of the diaphragm and separation of the steel portion is unlikely. However, this would be noticed at once because flow rate would fall considerably. In the event of damage, the loose steel component would be channelled by the pump housing. Even in the event of a malfunction, no sparks would therefore be generated mechanically.</p> <p>Replacing the diaphragm is described in Chapter 8, Servicing.</p>
Failure of ball bearings	<p>Have ball bearings replaced in accordance with the servicing schedule in Chapter 8.1.</p>

4. Technical data

Pump materials

The pump type **KP** stands for:

Assembly	Material ¹⁾
Pump head*	PP
Valve plate	EPDM
Diaphragm	PTFE-coated
Resonating diaphragm	PTFE
Diaphragm. 27	EPDM

Tab. 7

¹⁾ according to DIN ISO 1629 and 1043.1

The pump type **KT** stands for:

Assembly	Material ¹⁾
Pump head*	PP
Valve plate	FFKM
Diaphragm	PTFE-coated
Resonating diaphragm	PTFE
Diaphragm. 27	FFKM / FKM

Tab. 8

¹⁾ according to DIN ISO 1629 and 1043.1

The pump type **TT** stands for:

Assembly	Material ¹⁾
Pump head*	PVDF
Valve plate	FFKM
Diaphragm	PTFE-coated
Resonating diaphragm	PTFE
Diaphragm. 27	FFKM / FKM

Tab. 9¹⁾ according to DIN ISO 1629 and 1043.1

* The pump head (Fig. 1) comprises a connecting plate and an intermediate plate

Hydraulic ratings

Parameter	Value
Flow rate [l/min] ^{1), 2)}	≥ 3.0
Max. permissible pressure NF 1.300 [bar g]	4
Suction head [mWG]	2.5

Tab. 10

¹⁾ Measured with water at 20°C / at atmospheric pressure

²⁾ Flow rates may vary from the values shown, depending on fluid viscosity, pump head material and the hoses / hose connectors used.

Hydraulic connections

Parameter	Value
NF 1.300	G 3/8"
UNF 1.300	NPT 3/8"
Recommended hose size ID [mm]	12

Tab. 11

Specifications NF 1.300 Ex

Motor voltage	Value
Voltage [V]	230
Speed [RPM]	< 3500
Protection class [IP]	66
Weight ¹⁾ [g]	6000

Tab. 12

¹⁾ The weight may differ slightly from the stated value, depending on the version.



Other parameters

Parameter	Value
Permissible ambient temperature range (°C)	+ 5 to + 40
Permissible medium temperature range (°C)	+ 5 to + 40
Permissible kinematic viscosity of medium [cSt]	≤ 150

Tab. 13

Pump rating plate

- 1 Project number
- 2 Pump type
- 3 Company number (3 = KNF Flodos) and serial number
- 4 Permissible ambient temperature (see also Tab. 14)
- 5 Permissible speed
- 6 Date of manufacture (Month/Year)
- 7 Explosion prevention and protection marking
- 8 Certificate number
- 9 Permissible operating pressure
- 10 Flow rate (see also Tab. 11)

KNF www.knf.com  		
Made in Switzerland, 6210 Sursee		
1 PML: 14812	Dt.: 07/2019	6
2 Type: NF 1.300 TTE EX	Kennz.: Ex h IIB T5 Gb	7
3 No.: 3. 12860644	TPS 19 ATEX 039495 0007X	8
4 +5°C ≤ Ta ≤ 40°C	p_{max}: +400 kPa (4 bar)	9
5 n_{max}: 3500 rpm	V: 3 l/min	10

5. Assembly and function

Assembly

- 1 Condenser
- 2 Outlet
- 3 Pump head
- 4 Inlet
- 5 Motor
- 6 Motor base plate
- 7 Pump rating plate
- 8 Motor rating plate

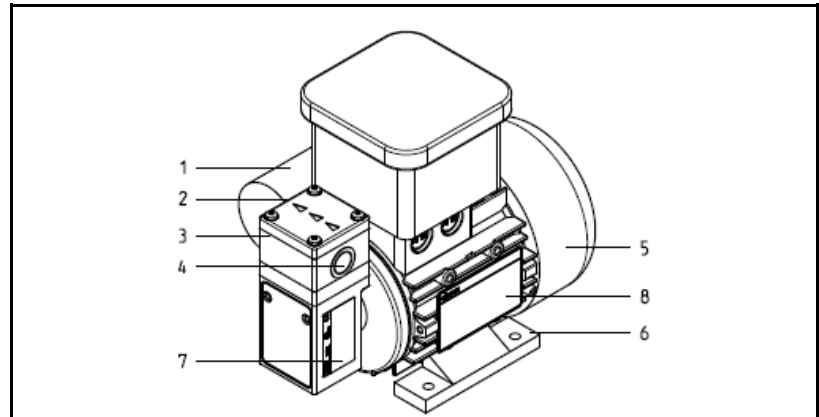

Fig. 1: Diaphragm liquid pump

- 1 Outlet valve
- 2 Inlet valve
- 3 Working chamber
- 4 Diaphragm
- 5 Eccentric
- 6 Connecting rod
- 7 Pump drive

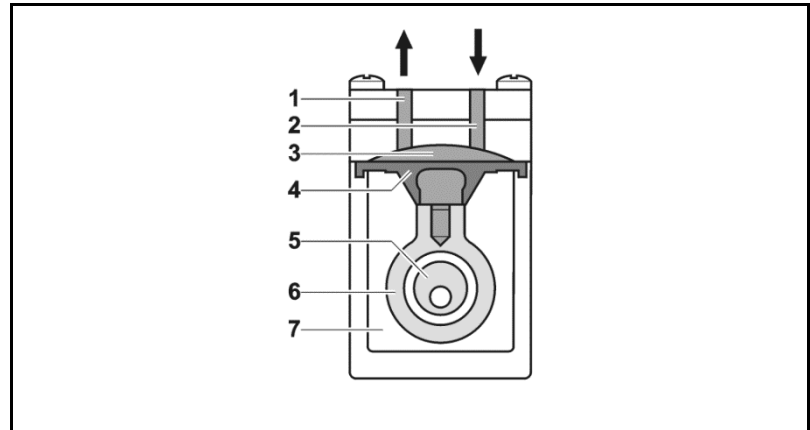

Fig. 2: Operating principle

The diaphragm liquid pumps are based on reciprocating displacement pump technology. The elastic diaphragm (4) is moved up and down by the eccentric (5) and the connecting rod (6). In the downward stroke it aspirates the medium to be transferred via the inlet valve (2). In the upward stroke, the diaphragm pushes the medium out of the pump head via the outlet valve (1). The diaphragm hermetically seals off the working chamber (3) from the pump drive (7).

NF 1.300 version (fixed flow rate)

This pump type represents this product in its simplest form and transfers medium at the fixed flow rate.

NF 1.300 .27 version (fixed flow rate with overpressure limiting)

If the diaphragm liquid pump is operating against a closed system, the delivery pressure quickly exceeds the maximum permissible values. To prevent this happening, an overflow valve is integrated in the top part of the pump head. If the pressure exceeds the variable limit range (min. 1.5 to max. 4.0 barg), the valve opens and the liquid circulates from the pressure side to the suction side via an internal bypass system. This prevents any further rise in pressure.

6. Installation and connection

Only install pumps under the operating parameters and conditions described in Chapter 4, Technical data, and in Section 2.3, Using the pump in a potentially explosive atmosphere.

Observe the safety precautions (see Chapter 3).

6.1. Installation

→ Before installation, store the pump at the installation location to bring it up to ambient temperature.

Mounting dimensions

→ Mounting dimensions (see Fig. 3)

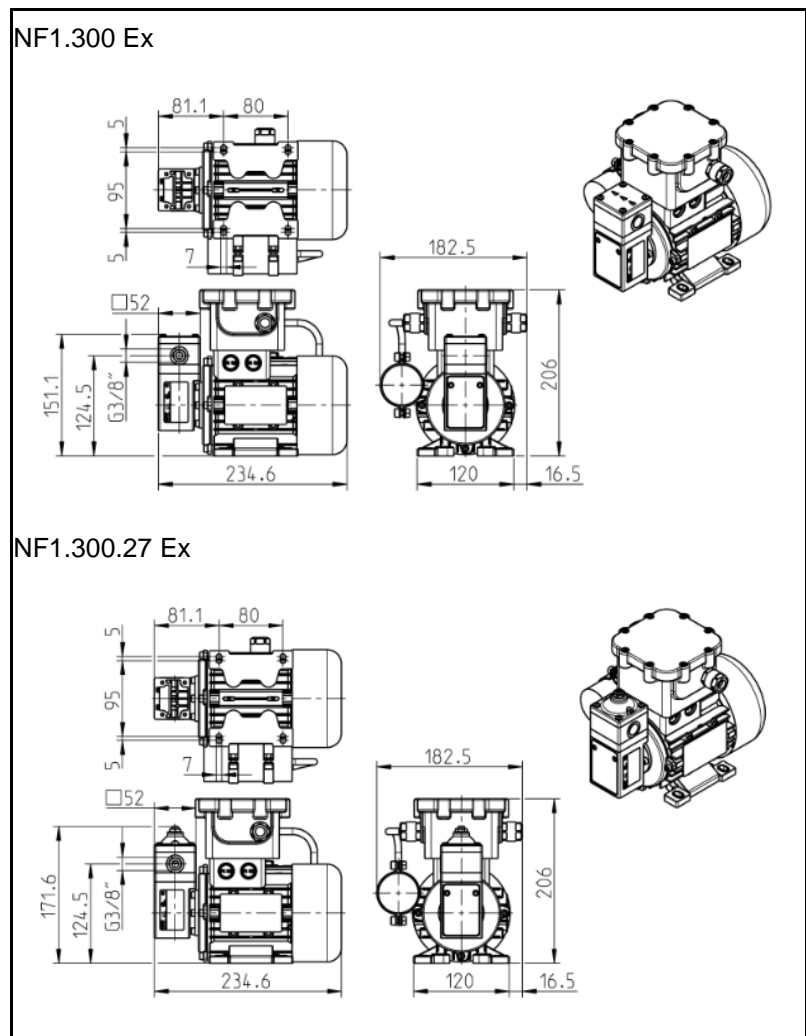

Fig. 3: Mounting dimensions NF1.300 Ex

Cooling air supply

→ For pumps with fan: When installing the pump, make sure that the motor's fan can draw in an adequate amount of cooling air.

Installation location

→ Make sure that the installation location is dry and the pump is protected against water in the form of rain, spray, splashes and drips.

→ Protect the pump against dust.

→ Protect the pump against vibration and impact.

- Installation position → Generally speaking, the pump can be mounted in any orientation. For maximum precision and rapid venting, install pump as shown in the illustration (Fig. 4).

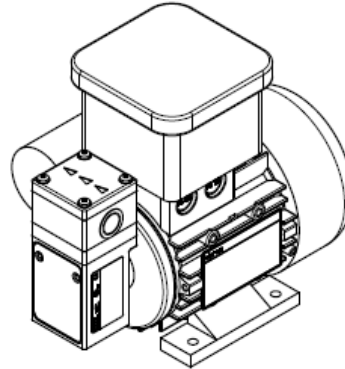

Fig. 4: optimum installation position / horizontal

- Decoupling → KNF recommends mechanically decoupling the pump from the piping system. This can be achieved with flexible hoses or pipes, for example. This prevents any oscillations of the pump being transferred to the system.

Contact and foreign-object protections



WARNING

Danger of injury during operation

- Take protective measures against touching parts which are energised (live), such as electrical connections or windings.
- Take protective measures against touching moving parts (e.g. fan).

Danger of damaging the pump during operation

- Take protective measures to ensure that no foreign objects can get into the pump (see protection class).

6.2. Electrical connection



WARNING

Danger of explosion as a result of incorrect electrical connection

May cause severe injuries or death

- Only connect pump/motor if it is safe to operate them in the explosive atmosphere concerned.
- Observe the Operating and Installation Instructions and the following requirements.



DANGER

Danger of electric shock, danger of death

- Only have the pump connected by an authorized specialist.
- Only have the pump connected when the power supply is disconnected.

- When connecting the device to a power source, the relevant norms, directives, regulations and technical standards must be observed.

**WARNING**

Danger of explosion as a result of electrostatic charge

- Connect the pump in such a way as to prevent the risk of ignition by electrostatic charge.
- Carefully earth the pump.

- | | |
|-----------------------------------|---|
| Drive motor | → Observe the Operating and Installation Instructions for the drive motor. |
| Potentially explosive atmospheres | <ul style="list-style-type: none"> → Only the electrical equipment required to operate the pump should be placed with it in potentially explosive atmospheres. → Take precautions to protect against lightning. |

Make sure that

- all electrical equipment meets the requirements for the area concerned (e.g. Emergency Stop switch, overcurrent release).
- the information on the drive motor's rating plate matches the nominal values of the electrical power supply. Voltage and frequency values must comply with the mains data (tolerance: $\pm 5\%$).
- the drive motor is protected against excessive heating by means of thermal/electromagnetic overcurrent releases, such as motor protective circuit switches in accordance with VDE 0660.
- the overcurrent release has been set to the rated current on the rating plate and the tripping response curve.
- safety devices have been fitted to ensure that the motor is protected even if a phase conductor fails.
- protection and overcurrent releases are set in such a way that after an item of equipment is triggered the drive motor is disconnected from the power supply (all poles). The release must not switch itself back on.
- precautions against atmospheric discharge (lightning) have been taken.
- all electrically conductive parts are earthed. Make sure that removable components such as safety devices, coupling elements etc. do not interrupt earth continuity.
- For circuit breakers and relays with current-dependent delayed tripping.

Connecting the pump

1. Connect individual conductors of the motor supply cable to the terminal bar. Tighten the clamping (pressure) screw of the screwed cable gland to a torque of 2.5 Nm.
2. Carefully inspect the marked earthing screw with non-rotating clamp inside the motor terminal box.
3. Connect earthing equipment conductor to earthing screw as shown in Fig. 5.

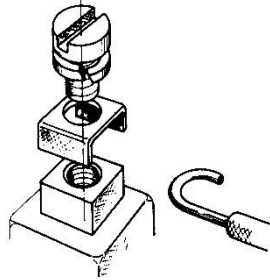

Fig. 5: Connecting the earthing equipment conductor

6.3. Hydraulic connection

- | | |
|------------------------|---|
| Connected components | → Only connect components to the pump that are designed to handle the hydraulic data of the pump (see Chapter 4, Technical data). |
| Hoses | → Only use hoses that are suitable for the maximum operating pressure of the pump (see Chapter 4).
→ Only use hoses that are sufficiently chemically resistant to the liquids being transferred. |
| Pressure relief device | → Protect the pump with a pressure relief device between the outlet side of the pump and the first shutoff valve. |



WARNING

Danger of explosion if the medium mixes with the environment during pressure relief

- Make sure that the medium cannot combine with the pump's environment during pressure relief.
- During pressure relief, make sure that the medium is captured in a suitable container in such a way that there is no danger of explosion.

6.3.1. Connecting the pump



Arrows on the pump head indicate the flow direction.

1. Remove the protective caps from the connections.
 2. Connect the suction and pressure lines.
- i** Keep the suction line as short as possible in order to keep the priming process as brief as possible.
3. If the pump is used to build up pressure, make sure that all transition joints between hose and pump are secure in order to ensure that the hoses cannot come off the hose connectors.
 4. Check that the hoses and transition joints are fitted correctly and securely.
 5. Check that the system is leak-tight.

7. Operation

- Only operate the pumps under the operating parameters and conditions described in Chapter 4, Technical data, and in Section 2.3, Using the pump in a potentially explosive atmosphere.
- Make sure that the pumps are being used properly (see Chapter 2.1).
- Avoid improper use of the pumps (see Chapter 2.2).
- Observe the safety precautions (see Chapter 3).
- The pumps are components that are intended to be incorporated into another machine. Before putting them into service it must be established that the machinery or systems in which they are installed meet the relevant regulations.



CAUTION

Risk of burning

The drive heats up.

- Avoid contact with the pump drive
- Avoid contact with flammable materials.



WARNING

Danger of bursting of the fluid system due to overpressure.

The pump builds up pressure. A closed system can cause the max. permitted operating pressure to be exceeded. This can cause injuries or damage to the pump and the system.

- Avoid operation against a closed system.
- Only use wetted parts that are rated for at least the operating pressure of the pump.
- If necessary, limit the maximum system pressure by suitable measures.

- i** Excessive pressure and the inherent dangers thereof can be prevented by placing a bypass line with a pressure relief valve between the pressure and suction side of the pump. For further information, contact your KNF technical adviser (Telephone number: see first page).



WARNING

Risk of explosion as a result of high ambient temperature

- Monitor ambient temperature (heat of compression, motor heat).
- Provide an adequate supply of cooling air.

- Pump standstill → If the pump stops running, restore the system to normal atmospheric pressure.
- Check the pump → Check the pump regularly for external damage or leaks.

Duty cycle / short cycle operation

Short cycle operation KNF pumps are designed for continuous operation.

i If the pump is operated with short cycles in your application, please contact a KNF technical adviser for further information (Telephone number: see first page).

Switching on the pump

→ In order to ensure that the pump starts every time, make sure that counterpressure is reduced to an acceptable level before start-up. This should also be done during operation after a brief power cut.

i For more specific information contact your KNF technical adviser.

Switching off the pump

→ KNF recommends: If transferring aggressive liquids, the pump should be flushed thoroughly prior to switch off (see Chapter 8.2.1), as this will help to lengthen the service life of the diaphragm.

→ Restore the system to normal atmospheric pressure (release hydraulic pressure in pump).

Flow rate NF 1.300

Fig. 6: Flow rate of the pump NF 1.300

8. Servicing

8.1. Servicing schedule

Component	Servicing interval
Pump	- Regular inspection for external damage or leaks
Pump head	- Clean if the flow rate decreases, the pump does not work or no vacuum is created (Chapter 8.2)
Diaphragm, valve plates and seals	- Change as soon as pumping capacity decreases, preferably sooner

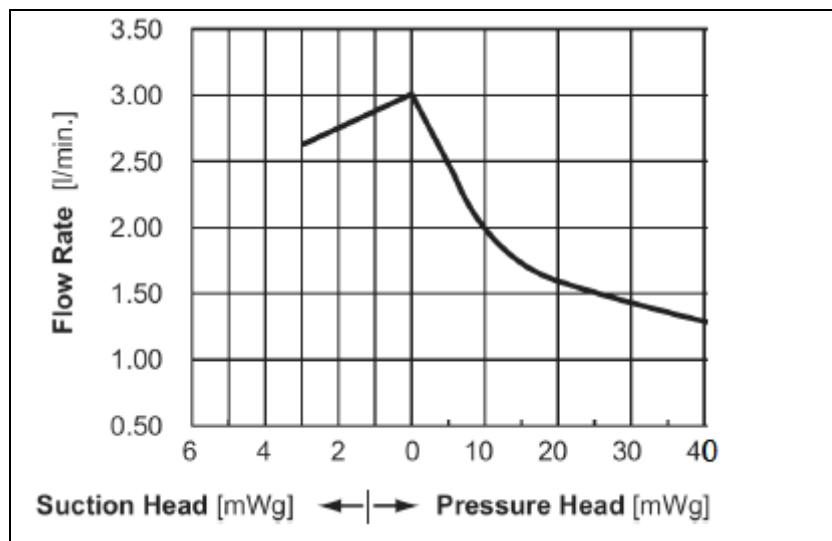
Tab. 14

Ball bearings

Standard regulations dictate that the bearings in the pump be replaced at regular intervals as a precautionary measure.

Depending on the pressure in your system the recommended time interval will vary - see table below.

Please contact your local KNF Company to discuss the best way of implementing this service.

Operating pressure [bar g]	Replacement interval
$p \leq 4$	20'000 operating hours

Tab. 15

8.2. Cleaning

Information on procedure



WARNING

Health hazard due to dangerous substances in the pump

Depending on the medium transferred, caustic burns or poisoning are possible.

→ Wear protective clothing if necessary, e.g. protective gloves.

→ Flush the pump with a neutral liquid and pump empty.

8.2.1. Flushing the pump

→ If transferring aggressive medium, KNF recommends flushing the pump with a neutral fluid under atmospheric conditions for a few minutes before switching off in order to extend the service life of the diaphragm.

**WARNING**

Risk of explosion as a result of flushing the pump with air

- In potentially explosive atmospheres, or when using the pump with potentially explosive medium, only allow the pump to be flushed with inert gas by specialist personnel.

8.2.2. Cleaning the pump

**WARNING**

Risk of explosion as a result of electrostatic charging of components

- Clean the pump with a moist towel only. Do not use flammable cleaning agents.

- If there is compressed air available, blow off components.
- Where possible, wipe the components with a dry cloth. Do not use cleaning solvents as these may corrode plastic parts.
- If there is compressed air available, blow off components.

Prior requirements

- Pump or drive disconnected from the mains and de-energized.
- The pump must be free of any hazardous substances
- Hoses must be disconnected from the pump head
- We recommend replacing the diaphragm when the head parts are removed.

Tool

Qty	Tools for KP, KP.51, KT and TT versions
1	Torx 20 screwdriver
1	Phillips screwdriver No. 2

Tab. 16

Dismantling the pump heads

1. Undo the four head screws (1) and remove the entire head

Removing the valves and seals

2. Remove the valve plate (8) from the intermediate plate (10).
3. Remove the resonating diaphragm (6), or resonating diaphragm.27 (21), diaphragm.27 (if fitted) (20), support.27 (19), U-washer.27 (18) and pressure spring.27 (17) from the connecting plate (7).
4. Remove O-ring Ø39 (5) and, if fitted, O-ring Ø14.5 (4) from the head plate.
5. Carefully grip the diaphragm (11) and remove by turning anti-clockwise. Remove the U-washers (12) and make sure that no U-washers (12) fall into the pump housing.

We recommend replacing the diaphragm (11).

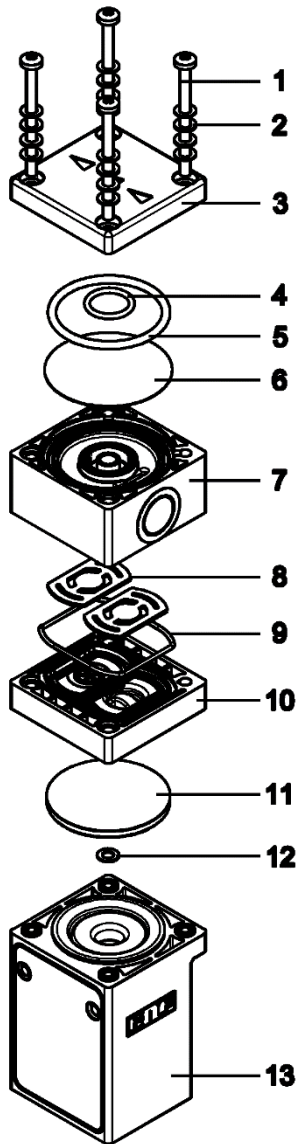

Fig. 7: NF 1.300

- 1 Head screws
- 2 U-washers \varnothing 8
- 3 Head plate
- 4 O-ring \varnothing 14.5
- 5 O-ring \varnothing 39
- 6 Resonating diaphragm
- 7 Connecting plate
- 8 Valve plates
- 9 Seal
- 10 Intermediate plate
- 11 Diaphragm
- 12 Washer \varnothing 8
- 13 Pump housing
- 14 Setscrew M8x0.5
- 15 Hexagon nut M8x0.5
- 16 Head plate.27
- 17 Spring.27
- 18 U-washer \varnothing 9
- 19 Support.27
- 20 Diaphragm.27
- 21 Resonating diaphragm.27

Cleaning the parts

6. Clean the diaphragm (11), O-ring \varnothing 14.5 (4), O-ring \varnothing 39 (5), diaphragm.27 (if fitted) (20), resonating diaphragm (6), or resonating diaphragm.27 (21), seal (9), valve plate (8), intermediate plate (10) and connecting plate (7) with a cloth and then blow off with compressed air.

Mounting the diaphragm

7. Place the same number of U-washers on the connecting rod (12) as were there previously. Make sure that no U-washers (12) fall into the pump housing.
8. Screw in the diaphragm (11).
9. By lightly pressing on the diaphragm push the ridge on the underside of the diaphragm into the groove of the housing.

Mounting the valve plates

10. Insert the "dust free" valve plates (8) and seal (9) in the intermediate plate (10), making sure they are in the correct position.

Assembling the pump head

- The method of assembly will depend on the pump type. For this reason, please proceed with the section that corresponds to the pump type you are using (**NF 1.300 version** or **NF 1.300.27 version**).
- Re-connect the hoses to the pump head.

NF 1.300 version

1. Insert the resonating diaphragm (6) in the connecting plate (7) and cover with the head plate (3) fitted with a new O-ring (4) and O-ring (5).
2. The positions of the intermediate plate (10), the connecting plate (7) and the head plate (3) are determined by the 3 locators (head screw elements).
3. Place the washers (2) for the head screws (1) on the through holes of the head plate (3) (no washers for FT).
4. Insert the four head screws (1) in the through holes of the pump head.
5. Make sure that the flow direction of the pump head (see directional arrow on the head plate (3)) is the same as previously.
6. Place the pump head onto the pump housing and alternately tighten the four head screws (1). The maximum tightening torque is 1.5 Nm.

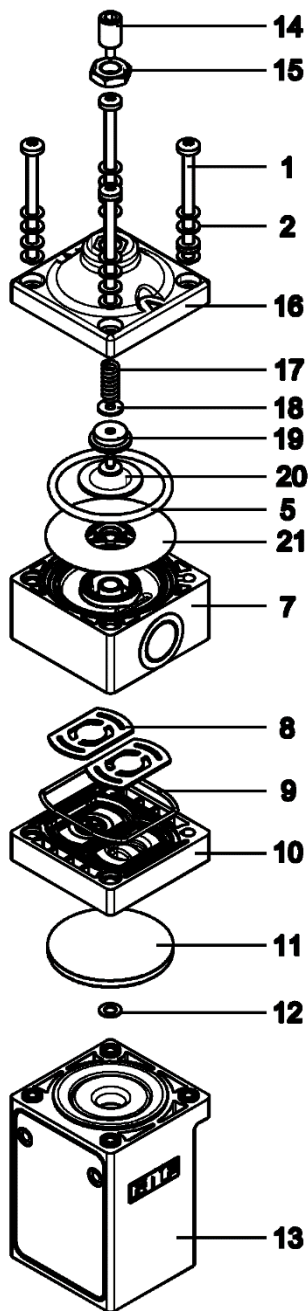

Fig. 8: NF 1.300.27

NF 1.300.27 version

1. Insert resonating diaphragm.27 (21) in the connecting plate (7).
2. Place diaphragm.27 (20) centrally on resonating diaphragm.27 (21).
3. Then place the support.27 (19), the U-washer.27 (18) and the compression spring.27 (17) over the diaphragm.27 (20).
4. Carefully place the head plate (16) with fitted new O-ring (5), screwed-in setscrew (14) and hexagon nut (15) over the whole unit.
5. The positions of the intermediate plate (10), the connecting plate (7) and the head plate (16) are determined by the 3 locators (head screw elements).
6. Place the washers (2) for the head screws (1) on the through holes of the head plate (16) (no washers for FT).
7. Insert the four head screws (1) in the through holes of the pump head.
8. Make sure that the flow direction of the pump head (see directional arrow on the head plate (16)) is the same as previously.
9. Place the pump head onto the pump housing and alternately tighten the four head screws (1). The maximum tightening torque is 1.5 Nm.

→ The activities described above should not alter the set pressure of the overflow valve. If it is found that the setting has changed after assembly, the value can be readjusted within the permissible range of the pump in accordance with the instructions in Chapter 8.4, if necessary readjusting the peripheral installations.

8.3. Replacing parts

Same procedure as in Chapter 8.2, "Cleaning", – with the exception of step 6:

Instead of cleaning the diaphragm (11), O-ring Ø14.5 (4), O-ring Ø39 (5), diaphragm.27 (20), resonating diaphragm (6) or resonating diaphragm.27 (21), seal (9) and valve plate 8, these components must be replaced.

8.4. Adjusting the overflow

1. Test set-up/instrumentation as shown in the diagram.

Test set-up for overflow

Make sure that the container (a), pump (b), pressure gauge (c) and valve (d) are as level as possible (+/- 15 cm)

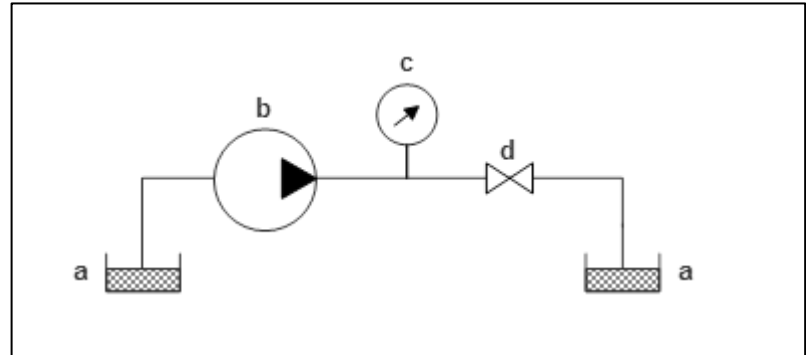

Fig. 9 Test set-up for overflow

2. Switch on the pump and run until there are no air bubbles in the system.
3. Close the valve downstream of the pressure gauge and check the overflow pressure at the gauge.
4. Undo the hexagon nut (15).
5. To reduce the pressure, turn the setscrew (14) anti-clockwise, to increase the pressure, turn it clockwise.
6. Use the hexagon nut (15) to secure the setscrew (14) in the selected position.

9. Troubleshooting



WARNING

Improper repairs and changes to explosion protected machines can create a danger of explosion.

- Observe national and international regulations regarding electrical equipment whenever performing servicing and repairs.
- Any work that could affect the explosion protection must be completed by the manufacturer. These tasks include, for example, repairing the stator or rotor coil, repairs to the terminals, and repairs on the ventilation system.



DANGER

Risk of electric shock, danger of death

- Disconnect the pump from the power supply before working on the pump.
- Make sure that the pump is de-energised.

- When troubleshooting, also observe the Operating and Installation Instructions for the drive motor.

Pump does not work	
Possible cause	Fault remedy
Pump not connected to mains power supply.	→ Connect pump to mains supply.
Power supply is not switched on.	→ Switch on power supply.
Connections or hoses are blocked.	→ Check connections and hoses. → Remove blockage.
External valve is closed or filter is clogged.	→ Check external valves and filters.
Diaphragm, valve plates or seals are worn	→ Replace diaphragm, anchor valves and seals (see Section 8.3).

Tab. 17

Pump is not priming	
Possible cause	Fault remedy
Suction side of pump not connected.	→ Connect the suction side of the pump.
Liquid in the container is too low.	→ Fill container.
Hose connections are not leak-tight.	→ Secure transition joints between hose and connections with clamps or clamping elements.
System valve is closed or filter is clogged.	→ Open the peripheral valve. → Clean filter.
Pump head is filled with gas. The system is unable to handle the pressure on the pressure side.	→ Reduce pressure at pressure side.
Particles in the pump.	→ Clean the pump head (see Section 8.2).

Pump is not priming	
Possible cause	Fault remedy
The head parts are not medium-resistant.	→ Replace the pump head with a compatible version.
Incorrect interchange of pressure and suction line connections.	→ Remove pressure and suction lines and re-connect correctly.

Tab. 18

Flow rate, suction head or pressure head is too low	
The pump does not achieve the performance stated in the technical data or on the data sheet.	
Possible cause	Fault remedy
Components in the system connected to the suction and pressure sides, such as hoses, valves or filters, are causing too much resistance.	→ Modify installation, check the cross-section of components.
Hose connections are not leak-tight.	→ Secure transition joints between hose and hose connections with clamps or clamping elements.
Particles in the pump.	→ Clean the pump head, install suction-side filter if required (see Section 8.2).
Viscosity of the liquid is too high.	→ Contact KNF.
Incorrect interchange of pressure and suction line connections.	→ Remove pressure and suction lines and re-connect correctly.
The head parts are not medium-resistant.	→ Replace the pump head with a compatible version.

Tab. 19

Motor malfunction				Possible cause	Remedy
Motor does not start up	Motor is too warm	Speed drops considerably	Protective device is triggered		
				Counter torque too high	Check motor torque and load torque
				Mains voltage too low	Check state of mains power
				Phase interruption	Check connection network
				Wiring incorrect	Observe circuit diagram and rating plate
				Overload	Compare information on rating plate
				Switching frequency too high	Observe rated operating mode
				Inadequate ventilation	Inspect cooling air channels and check direction of rotation
				Ventilation paths soiled	Clean
				Winding or terminal short circuit	Measure insulation resistance

Motor malfunction				Possible cause	Remedy
Motor does not start up	Motor is too warm	Speed drops considerably	Protective device is triggered		
				Start-up time exceeded	Check start-up conditions

Tab. 20

Fault cannot be rectified

If you are unable to identify any of the above causes, please send the pump to KNF customer service (see address on last page).

1. Flush the pump to clear the pump head of any hazardous or aggressive fluids (see Chapter 8.2.1).
2. Dismantle the pump.
3. Clean the pump (see Chapter 8.2.2).
4. Send the pump, with completed decontamination declaration (see Chapter 10), to KNF customer service stating the nature of the transferred medium.

10. Return of the pump

i KNF undertakes to repair the pump only under the condition that the customer provides a certificate of the pumped medium and cleaning of the pump. For this purpose, please follow the instructions on www.knf.com/repairs.

Please contact your KNF sales representative directly if you need additional support for your return service.

KNF worldwide

Please find your local KNF partners at: www.knf.com

