

DIAPHRAGM LIQUID PUMP

NF 25, NFB 25

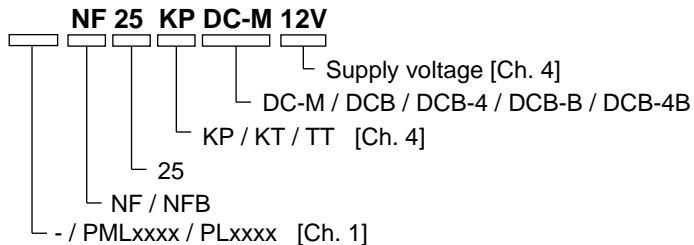

Operating and Installation Instructions

Read and observe these Operating and Installation Instructions!

An additional letter prefixing the NF model code is a country-specific designation, with no technical relevance.

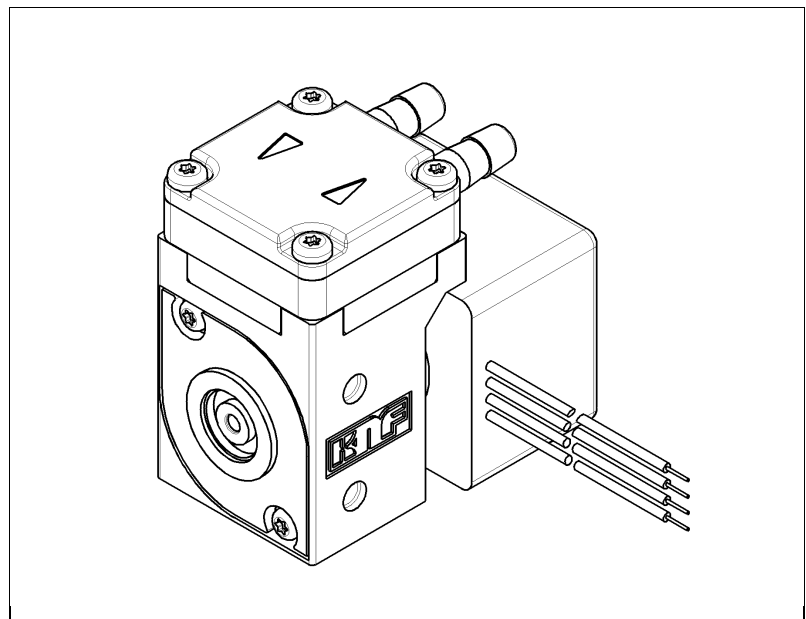

KNF Flodos AG
 Wassermatte 2
 6210 Sursee, Switzerland
 Tel +41 (0)41 925 00 25
 Fax +41 (0)41 925 00 35
 www.knf.com
 info.flodos@knf.com

Contents	Page
1. About this document.....	2
2. Use	3
3. Safety	4
4. Technical data	6
5. Assembly and function	9
6. Installation and connection.....	10
7. Operation.....	15
8. Servicing.....	20
9. Troubleshooting.....	23
10. Accessories	25
11. Return of the pump.....	26

1. About this document

1.1. Use of the Operating and Installation Instructions

The Operating and Installation Instructions are part of the pump.

- ➔ Forward the Operating and Installation Instructions to any subsequent owners of the pump.

Project pumps

Customer-specific project pumps (pump models which begin with "PL" or "PML") may differ from the Operating and Installation Instructions.

- ➔ In the case of project pumps, take note of any additionally agreed specifications.

1.2. Symbols and markings

Warning



WARNING

This symbol indicates a potential danger.

It also indicates the possible consequences of failure to observe the warning. The signal word (e.g. "Warning") indicates the level of danger.

- ➔ Here you will see actions for avoiding the danger and potential consequences.

Danger levels

Signal word	Meaning	Consequences if not observed
DANGER	warns of immediate danger	Consequences are death or serious injury and/or serious property damage.
WARNING	warns of potential danger	Death or serious injury and/or serious damage to property are possible.
CAUTION	warns of a potentially dangerous situation	Minor injury or damage to property are possible.

Tab. 1

Other information and symbols

- ➔ This indicates a required activity (step).
- 1. This indicates the first step of a required activity. Additional consecutively numbered steps follow.

i This symbol indicates important information.

2. Use

2.1. Intended use

The pumps are intended for transferring and metering liquids and gases.

Owner's responsibility

Operating parameters and conditions

Only install and operate the pumps under the operating parameters and conditions described in Chapter 4, Technical data.

Only completely installed pumps may be taken into service.

Requirements for transferred medium

Before transferring or metering a medium, check whether the medium can be transferred danger-free in the specific application case.

Before using a medium, check the compatibility of the materials of the pump head, pump housing, diaphragm and valves with the medium.

The temperature of the medium must lie within the permissible temperature range (see Chapter 4).

The transferred medium should not contain particles as these can prevent the pump from working correctly. If this cannot be guaranteed, a filter < 50 µm with sufficiently large filter area must be used upstream of the pump.

→ Filters may be ordered as accessories, see Spare Parts and Accessories (Chapter 10).

2.2. Improper use



The pumps must not be operated in an explosive atmosphere.

DANGER



Please contact your local KNF partner for special designs that are not included in the technical specification (www.knf.com).

3. Safety

- i** Observe the safety precautions in Chapters 6. Installation and connection and 7. Operation.

The pumps are built according to the generally recognised rules of technology and in accordance with the pertinent occupational safety and accident prevention regulations. Nevertheless, dangers may occur during their use which may lead to injuries to the user or others, or to damage to the pump or other property.

Only use the pumps when they are in a good technical and proper working order, in accordance with their intended use, observing the safety advice within the Operating and Installation Instructions, at all times.

Personnel	<p>Make sure that only trained and instructed personnel or specially trained personnel work on the pumps. This especially applies to assembly, connection and servicing work.</p> <p>Make sure that all personnel have read and understood the Operating and Installation Instructions, and in particular the "Safety" chapter.</p>
Working in a safety-conscious manner	Always ensure adherence to all pertinent accident prevention and safety regulations when working on and operating the pump.
Handling dangerous media	When transferring dangerous media, observe the safety regulations for handling such media.
Notes	Always ensure adherence to all information stickers on the pumps, such as flow direction arrows and type plates, and keep stickers in legible condition.
Environmental protection	All replacement parts should be properly stored and disposed of in accordance with the applicable environmental protection regulations. Observe the respective national and international regulations. This especially applies to parts contaminated with toxic substances.
Disposal	<p>Dispose of all packaging in an environmentally-appropriate manner. The packaging materials are recyclable.</p> <p>Dispose of end-of-life equipment in an environmentally friendly manner. Use appropriate waste collection systems for the disposal of end-of-life equipment. Used pumps contain valuable recyclable materials.</p>



EU directives/standards	<p>The pumps comply with the fundamental requirements of Directive 2011/65/EU (RoHS2).</p> <p>For the purposes of the Machinery Directive 2006/42/EC, pumps are “partly completed machinery”, and are therefore to be regarded as not ready for use. Partly completed machinery may not be commissioned until such time as it has been determined that the machine in which the partly completed machinery is to be assembled conforms to the provisions of the Machinery Directive 2006/42/EC. The essential requirements of Annex I of Directive 2006/42/EC (general principles) are applied and observed.</p> <p>The following harmonised standards are met:</p> <p>NF 25 DC-M</p> <ul style="list-style-type: none">▪ EN 55022▪ EN 55011 <p>NF 25 DCB / DCB-4</p> <ul style="list-style-type: none">▪ EN 61000-6-2▪ EN 61000-6-3 (incl. EN 55022 / EN 55011) <p>NFB 25 DCB-B / DCB-4B</p> <ul style="list-style-type: none">▪ IEC/EN 61000-6-2▪ IEC/EN 61000-6-3
Customer service and repairs	<p>All repairs to the pump(s) must be carried out by the relevant KNF customer service team.</p> <p>Only use genuine parts from KNF for servicing work.</p>

4. Technical data

Pump materials

The pump type **KP** stands for:

Assembly	Material ¹⁾
Pump head*	PP
Valve plate / seals	EPDM
Diaphragm	EPDM
Resonating diaphragm	EPDM

Tab. 2

¹⁾ according to DIN ISO 1629 and 1043.1

The pump type **KT** stands for:

Assembly	Material ¹⁾
Pump head*	PP
Valve plate / seals	FFKM
Diaphragm	PTFE-coated
Resonating diaphragm	FFKM

Tab. 3

¹⁾ according to DIN ISO 1629 and 1043.1

The pump type **TT** stands for:

Assembly	Material ¹⁾
Pump head*	PVDF
Valve plate / seals	FFKM
Diaphragm	PTFE-coated
Resonating diaphragm	FFKM

Tab. 4

¹⁾ according to DIN ISO 1629 and 1043.1

* The pump head (Fig. 1) comprises a connecting plate and an intermediate plate.

Hydraulic ratings

Parameter	Value
Flow rate NF 25 DC-M and DCB [ml/min] ^{1), 2)}	250
Flow rate NF 25 DCB-4 [ml/min] ^{1), 2)}	25-250
Flow rate NFB 25 DCB-4B [ml/min] ^{1), 2)}	2x 50-300
Flow rate NFB 25 DCB-B [ml/min] ^{1), 2)}	2x 300
Permissible pressure [bar g]	1
Suction head [mWG]	3

Tab. 5

¹⁾ Measured with water and using KNF standardised test equipment at atmospheric pressure, KP pump head material

²⁾ Flow rates may vary from the values shown, depending on fluid viscosity, ambient temperature, pump head material and the hoses / hose connectors used.

Hydraulic connections

Parameter	Value
Recommended hose size ID [mm]	4

Tab. 6

Specifications NF 25 DC-M

Motor voltage	12V	24V
Power consumption [W]	2.9	2.9
Max. I load [A]	0.24	0.12
Max. permissible current consumption [A]	0.31	0.14
Lead size [-]	AWG22	
Protection class [-]	IP30	
Weight ¹⁾ [g]	64	

Tab. 7

Specifications NF 25 DCB / DCB-4

Motor option	DCB-4	DCB 12V	DCB 24V
Supply voltage [V]	10...26.4	12	24
Power consumption [W]	2.9	2.8	2.9
I load max. [A]	0.11...0.25	0.23	0.12
Lead size [-]	AWG28		
Protection class	IP40		
Weight ¹⁾ [g]	60		

Tab. 8

i In the case of type NF25 DCB-4, the supply voltage is not designed for operation with pulse-width modulated voltages (PWM).

However, a PWM signal (frequency 1-20kHz) can be used to control the control voltage.

i Electrostatic sensitive components (ESD)

1) The weight may differ slightly from the stated value, depending on the version

Specifications NFB 25 DCB-B / DCB-4B

Motor option	DCB-4B	DCB-B	DCB-B
Supply voltage [V]	10...26.4	12	24
Power consumption [W]	5.4	6.5	6.5
I load max. [A]	0.22...0.54	0.54	0.27
Protection class	IP50		
Weight ¹⁾ [g]	210		

Tab. 9

i In the case of type NFB25 DCB-4B, the supply voltage is not designed for operation with pulse-width modulated voltages (PWM).

However, a PWM signal (frequency 1-20kHz) can be used to control the control voltage.

i Electrostatic sensitive components (ESD)

1) The weight may differ slightly from the stated value, depending on the version.

Other parameters

Parameter	Value
Permissible ambient temperature range [C]	+ 5 to + 40
Permissible media temperature [C]	+ 5 to + 80
Permissible kinematic viscosity of medium [cSt]	≤ 150

Tab. 10

5. Assembly and function

Assembly

- 1 Outlet
- 2 Inlet
- 3 Connecting plate
- 4 Drive
- 5 Connecting leads
- 6 Head plate
- 7 Intermediate plate

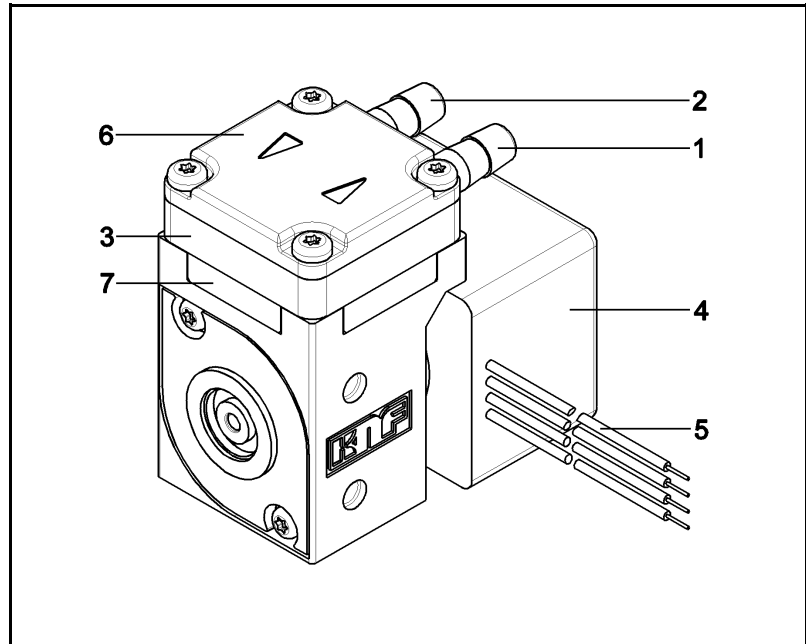

Fig. 1: Micro diaphragm liquid pump NF 25

- 1 Outlet valve
- 2 Inlet valve
- 3 Working chamber
- 4 Diaphragm
- 5 Eccentric
- 6 Connecting rod
- 7 Pump drive

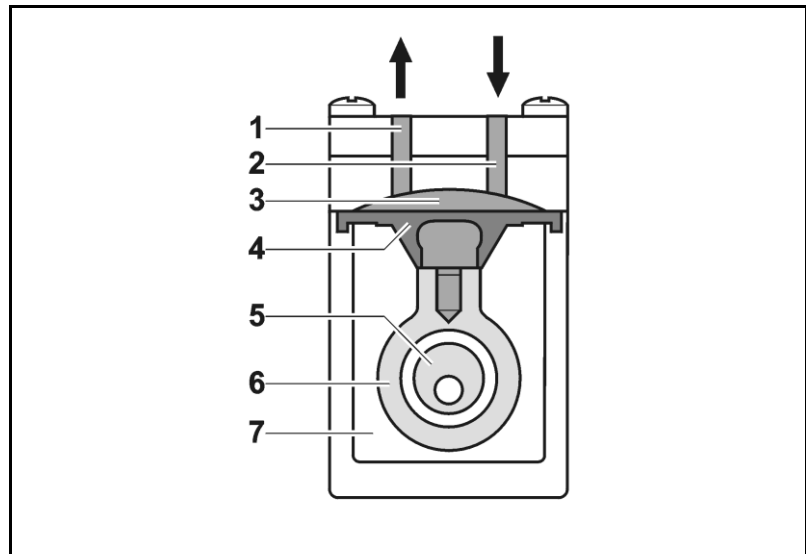

Fig. 2: Pump assembly

The diaphragm liquid pumps are based on reciprocating displacement pump technology. The elastic diaphragm (4) is moved up and down by the eccentric (5) and the connecting rod (6). In the downward stroke it aspirates the medium to be transferred via the inlet valve (2). In the upward stroke the diaphragm pushes the medium out of the pump head via the outlet valve (1). The diaphragm hermetically seals off the working chamber (3) from the pump drive (7).

NFB 25 Version (double-headed pump, see Fig. 3)

This pump type has two NF25 pump heads that can be operated individually or in parallel connection (see Chapter 0).

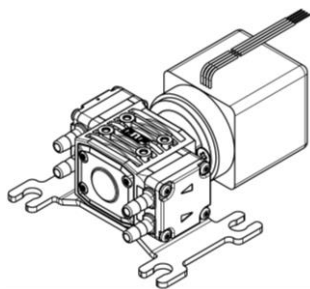

Fig. 3: NFB 25
(double-headed pump)

6. Installation and connection

Only install the pump under the operating parameters and conditions described in Chapter 4, Technical data.

Observe the safety precautions (see Chapter 3).

6.1. Installation

→ Before installation, store the pump at the installation location to bring it up to ambient temperature.

Mounting dimensions

→ Mounting dimensions (see Fig. 4 to 6)

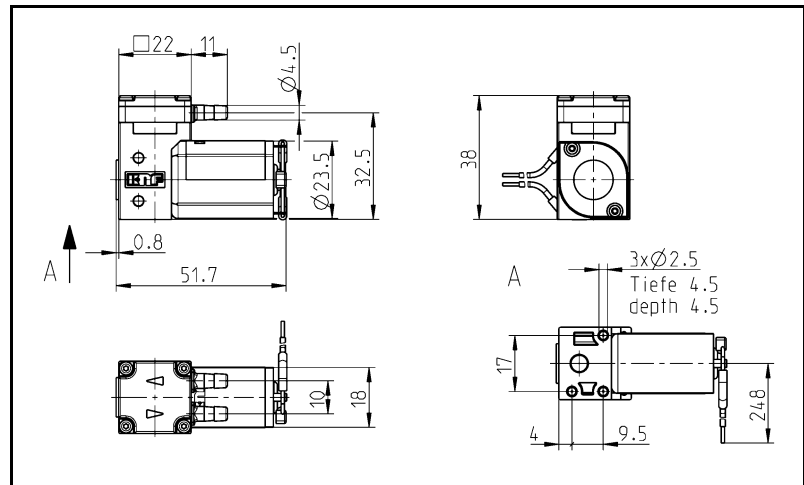

Fig. 4: Mounting dimensions NF 25 DC-M

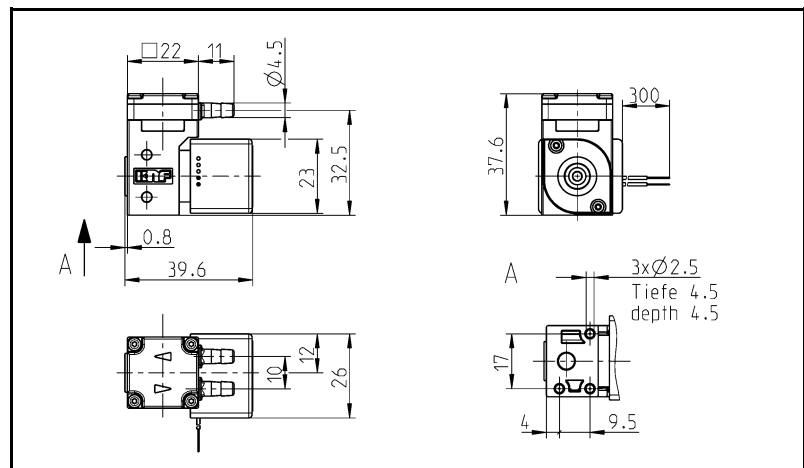

Fig. 5: Mounting dimensions NF 25 DCB

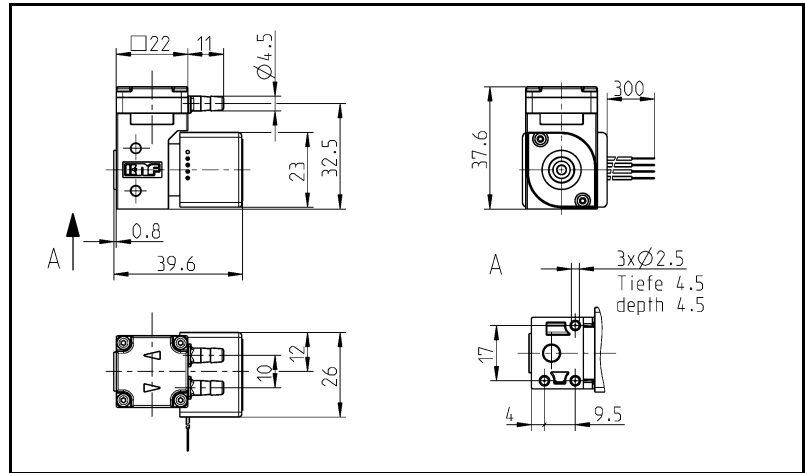

Fig. 6: Mounting dimensions NF 25 DCB-4

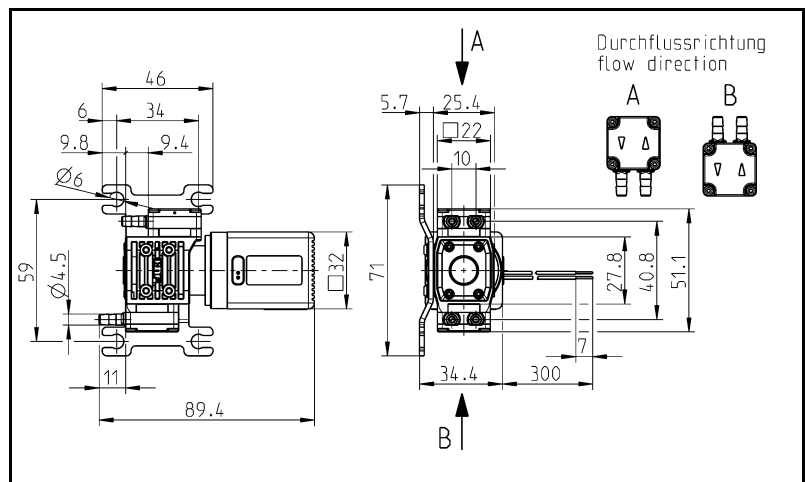

Fig. 6: Mounting dimensions NFB 25 DCB-B

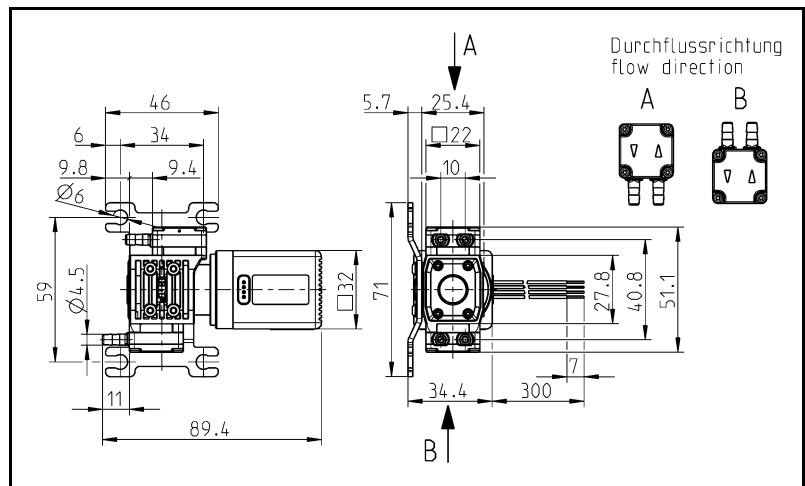
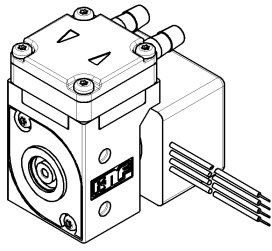

Fig. 8: Mounting dimensions NFB 25 DCB-4B

- Installation location
- ➔ Make sure that the installation location is dry and the pump is protected against water in the form of rain, spray, splashes and drips.
 - ➔ Protect the pump against dust.
 - ➔ Protect the pump against vibration and impact.

Installation position



- Generally speaking, the pump can be installed in any position. For maximum accuracy and rapid venting of one-headed pumps, please install as shown in the illustration (Fig. 7).

Fig. 9: Optimum installation position for one-headed pumps: horizontal

6.2. Electrical connection

- Only have the pump connected by an authorized specialist.
- Only have the pump connected when the power supply is disconnected.
- When connecting the device to a power source, the relevant norms, directives, regulations and technical standards must be observed.

Connecting the pump

1. Make sure that the power supply data match the data on the motor's type plate. The current consumption can be found on the type plate.
2. Connect the motor cables. For electrical data see Chapter 4.

i Note the proper polarity.

For DC motors:
 red motor cable: +
 black motor cable: -

6.3. Hydraulic connection

Connected components

- Only connect components to the pump that are designed to handle the hydraulic data of the pump (see Chapter 4, Technical data).

Hoses

- Only use hoses that are suitable for the maximum permissible operating pressure of the pump (see Chapter 4).
- Only use hoses that are sufficiently chemically resistant to the liquids being transferred.

6.3.1. Connecting the pump

i Arrows on the pump head indicate the flow direction.

1. Remove the protective caps.
2. Connect the suction and pressure lines.

i Keep the suction line as short as possible in order to keep the priming process as brief as possible.

3. If the pump is used to build up pressure, make sure that all transition joints between hose and pump are secure in order to ensure that the hoses cannot come off.
4. Check that the hoses and transition joints (hose connector/hose) are fitted correctly and securely.
5. Check that the system is leak-tight.

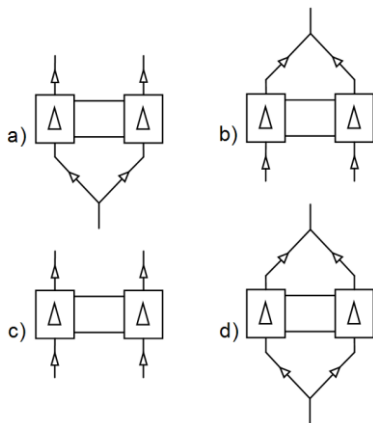

Fig. 10: Hose connection options for NFB versions

6.3.2. NFB 25 hose configuration

i A double-headed pump is normally selected to reduce the pressure surges caused by the alternation between suction and exhaust in a diaphragm pump. In order to achieve this effect, in addition to the pump configuration it is important to configure the hoses correctly.

For low pulsation (pressure surges) in NFB pumps:

- ➔ Configure pump head hoses in parallel (see Fig. 8).
- ➔ Keep hoses between pump and junction as short as possible.
- ➔ Cause as little narrowing as possible with connection elements. Recommendation: Min. inside diameter 3mm.

Please contact your local KNF partner for further information

i (www.knf.com).

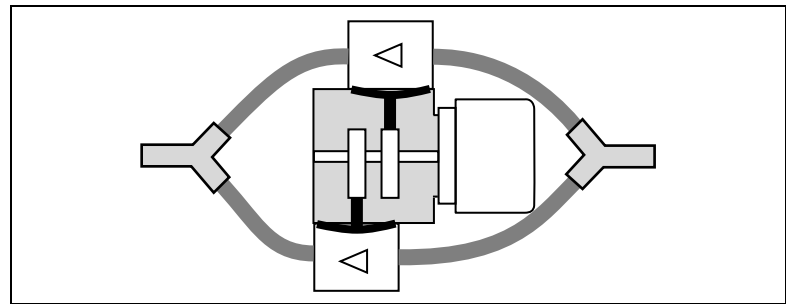

Fig. 11: NFB hose configuration for low pulsation

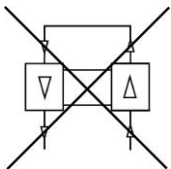

Fig. 12: No series connection in the case of NFB versions



Series connection damages pump

If the two heads in the NFB versions are connected in series, the pump will be damaged, and may leak.

CAUTION

7. Operation

- Operate the pumps only under the operating parameters and conditions described in Chapter 4, Technical data.
- Make sure that the pumps are being used properly (see Chapter 2.1).
- Avoid improper use of the pumps (see Chapter 2.2).
- Observe the safety precautions (see Chapter 3).
- The pumps are components that are intended to be incorporated into another machine. Before putting them into service it must be established that the machinery or systems in which they are installed meet the relevant regulations.



CAUTION

Risk of burning

The drive heats up.

- Avoid contact with the pump drive.
- Avoid contact with flammable materials.



WARNING

Danger of bursting of the fluid system due to overpressure.

The pump builds up pressure. A closed system can cause the max. permitted operating pressure to be exceeded. This can cause injuries or damage to the pump and the system.

- Avoid operation against a closed system.
- Only use wetted parts that are rated for at least the operating pressure of the pump.
- If necessary, limit the maximum system pressure by suitable measures.



Excessive pressure and the inherent dangers thereof can be prevented by placing a bypass line with a pressure relief valve between the pressure and suction side of the pump. Please contact your local KNF partner for further information (www.knf.com).



CAUTION

Risk of burns when transferring hot media

→ Do not touch the pump or the media transfer system.

- Avoid contact with flammable materials.

Pump standstill → If the pump stops running, restore the system to normal atmospheric pressure.

For pumps with thermal switch or electronic overload protection:



Risk of physical injury and damage to the pump due to automatic start

WARNING

If the pump overheats and pump operation is stopped by the thermal switch / electronics, the pumps will restart automatically as soon as they have had time to cool down.

- ➔ Take steps to ensure that this cannot produce a hazardous situation.

Switching the pumps on and off

Setting and regulating motor speed The motor speed of the pumps, and thus the flow rate, is adjustable and can also be regulated to some extent.
 For more details, see Chapter 4, Technical data.

Duty cycle / short cycle operation

Short cycle operation KNF pumps are designed for continuous operation.
 Short start and stop cycles may adversely affect the service life of the brushed motors.

i If the pump is operated with short cycles in your application, please contact your local KNF partner for further information (www.knf.com.)

Switching on the pump

→ In order to ensure that the pump starts every time, make sure that counterpressure is reduced to an acceptable level before start-up. This should also be done during operation after a brief power cut. Please contact your local KNF partner for further information (www.knf.com).

Switching off the pump

- KNF recommends: If transferring aggressive liquids, the pump should be flushed thoroughly prior to switch off (see Chapter 8.2.1), as this will help to lengthen the service life of the diaphragm.
- Restore the system to normal atmospheric pressure (release hydraulic pressure in pump).



CAUTION

Overpressure on the suction side causes medium to flow through the switched-off pump

→ Take steps to ensure that this cannot produce a hazardous situation.

Flow rate NF 25

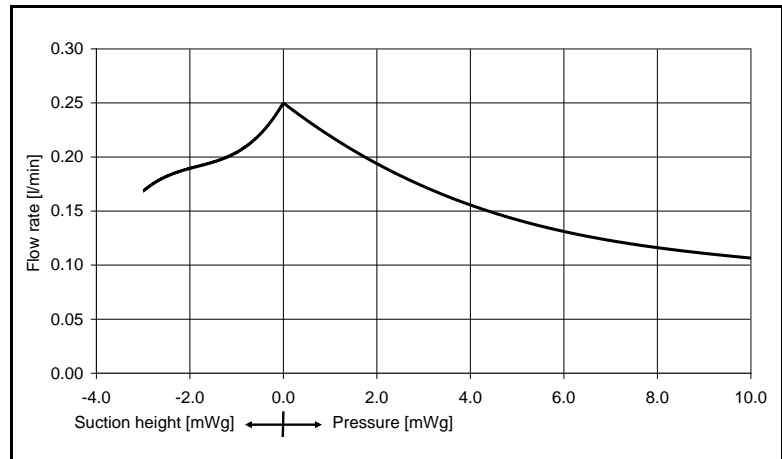

Fig. 13: Flow rate of pump NF 25 DC-M

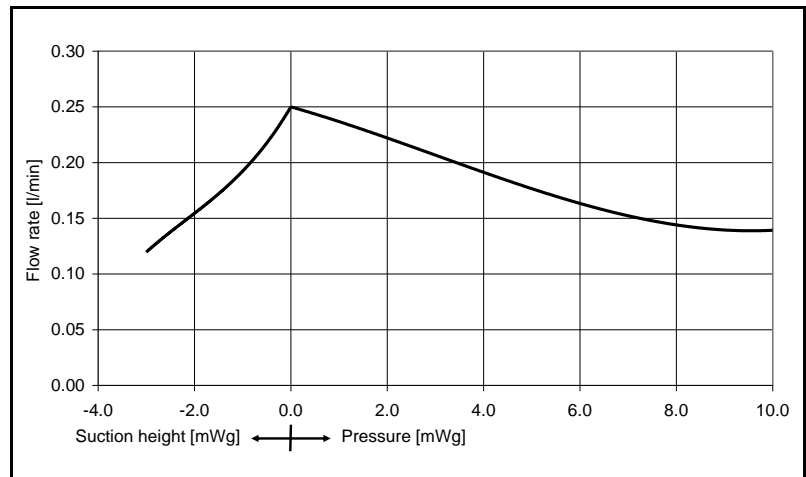

Fig. 14: Flow rate of pump NF 25 DCB and NF 25 DCB-4

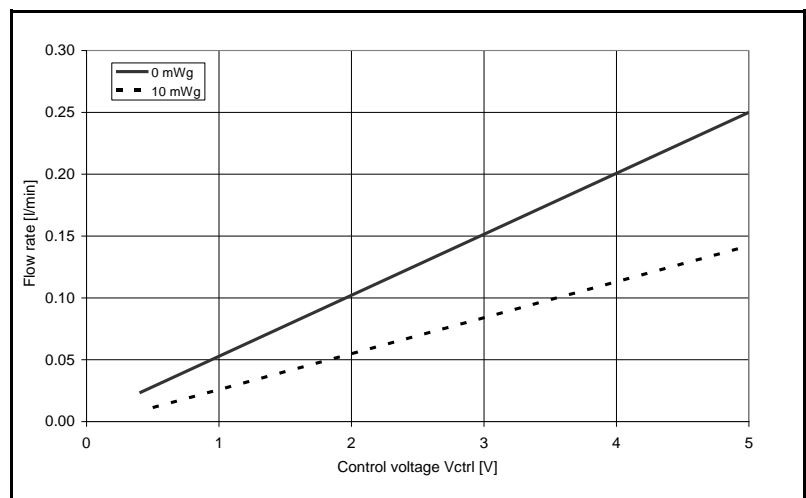

Fig. 15: Flow rate of pump NF 25 DCB-4 depending on control voltage

Flow rate NFB 25

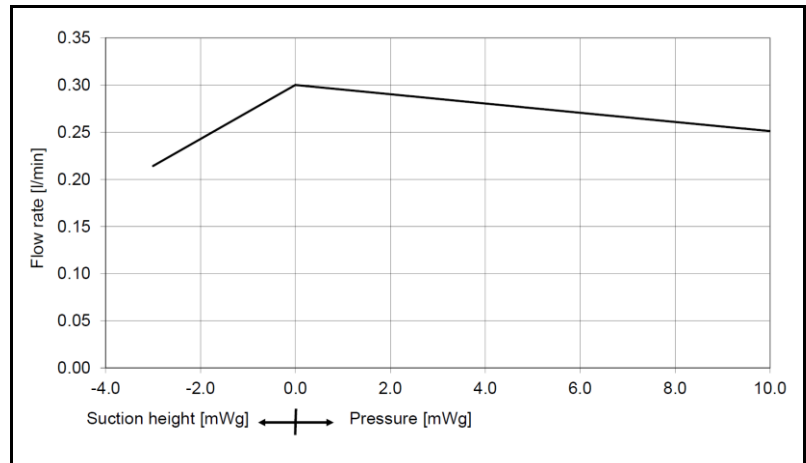

Fig. 16: Flow rate of pump NFB 25 DCB-B and NFB 25 DCB-4B (per pump head)

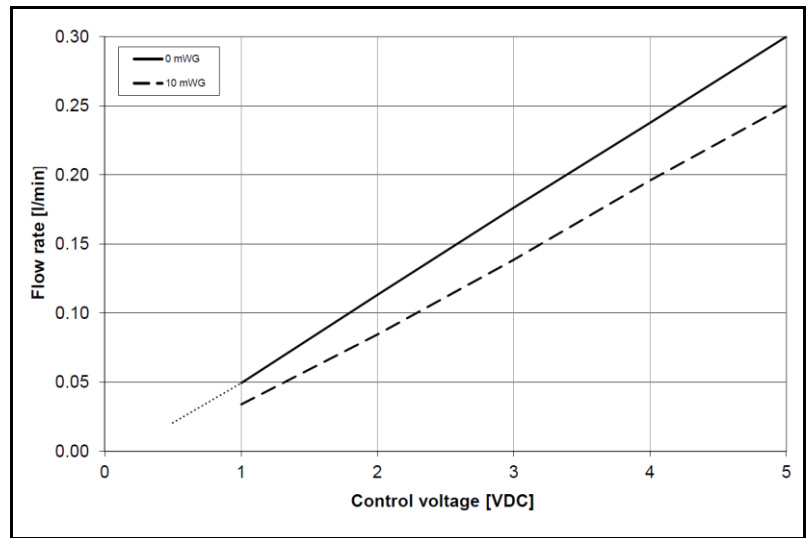

Fig. 17: Flow rate of pump NFB 25 DCB-4B depending on control voltage (per pump head)

8. Servicing

8.1. Servicing schedule

Component	Servicing interval
Pump	- Regular inspection for external damage or leaks
Pump head	- Clean if the flow rate decreases, the pump does not work or no vacuum is created (Chapter 8.2)
Diaphragm, valve plates and seals	- Change as soon as pumping capacity decreases, preferably sooner

Tab. 11

8.2. Cleaning and dismantling

Information on procedure



Health hazard due to dangerous substances in the pump

WARNING

Depending on the medium transferred, caustic burns or poisoning are possible.

- Wear protective clothing if necessary, e.g. protective gloves.
- Flush the pump with a neutral liquid and pump empty.
- With NFB pumps, make sure that both pump heads are flushed.



With NFB pumps the necessary steps are repeated for the second pump head.

8.2.1. Flushing the pump

- If transferring aggressive media, KNF recommends flushing the pump with a neutral fluid under atmospheric conditions for a few minutes before switching off, to extend the service life of valves and diaphragm.

8.2.2. Preparations for disassembly

1. Flush the pump with a suitable neutralising liquid, and make sure that no dangerous substances are left in the pump.
2. Pump empty.
3. Separate electrical connections.
4. Disconnect hoses from pump head.

Tools

Qty	Tools
1	T6 Torx screwdriver

Tab. 12

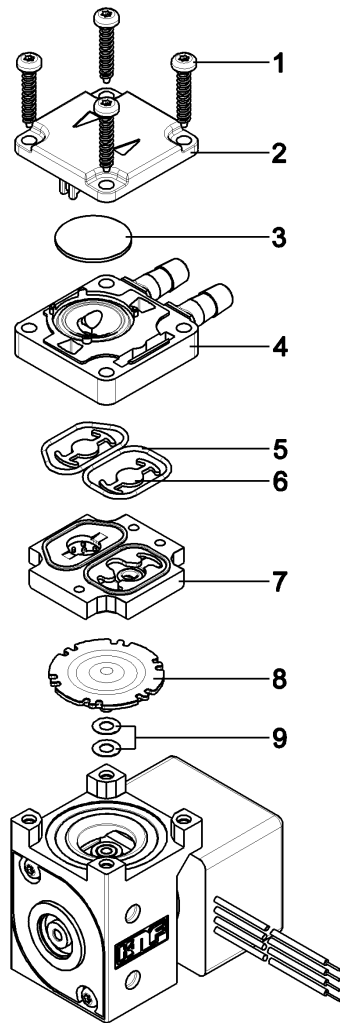

Fig. 18

- 1 Head screws
- 2 Head plate
- 3 Resonating diaphragm
- 4 Connecting plate
- 5 Anchor valve seals
- 6 Anchor valves
- 7 Intermediate plate
- 8 Diaphragm
- 9 Washer

8.2.3. Disassembling the pump head

1. Loosen the four head screws (1) and remove the entire head.
2. Remove the resonating diaphragm (3) from the connecting plate (4).
3. Remove both anchor valves (6) from the intermediate plate (7) and the connecting plate (4).
4. Remove the two anchor valve seals (5) from the connecting plate (4).
5. Undo the diaphragm (8) by means of the head plate (2). Remove the washers and make sure that no washers (9) fall into the pump housing.

We recommend replacing the diaphragm (8).

8.2.4. Clean or replace parts

1. Clean the anchor valves (6), the anchor valve seals (5) and the diaphragm (8) with a cloth and then blow off with compressed air or replace.
2. Blow off the intermediate plate (7), connecting plate (4) and head plate (2) with compressed air.

8.2.5. Assembling the pump head

1. Screw diaphragm (8) with washer (9) into connecting rod. Make sure that no washers (9) fall into the pump housing.
2. Use the head plate (2) to carefully tighten the diaphragm.
3. Insert the seals (5) in the connecting plate (4).
4. Insert the anchor valves (6) in the intermediate plate (7) and the connecting plate (4).
5. Place the connecting plate (4) on top of the intermediate plate (7).
A pin and hole system prevents incorrect assembly.
6. Insert the resonating diaphragm (3) into the connecting plate (4).
7. Place the head plate (2) on top of the connecting plate (4). A pin and hole system prevents incorrect assembly.
8. Insert the four head screws (1) into the through holes of the pump head.
9. Place the pump head on top of the pump housing and make sure that the flow direction of the pump head (see directional arrow on the head plate (2)) is the same as before.
10. Alternately tighten the four head screws (1).
11. Reconnect the hoses to the pump head.

**CAUTION****Escaping liquid**

After assembly the pump may not be leak-tight due to incorrect assembly, damaged or soiled seal faces, or other reasons.

- Run pump for several minutes with a harmless liquid at maximum operating pressure.
 - Check that pump is leak-tight.
-

9. Troubleshooting

- ➔ Disconnect the pump from the power supply before working on the pump.
- ➔ Make sure that the pump is de-energised.

Pump does not work	
Possible cause	Remedy
Pump not connected to power supply	➔ Connect pump to power supply
Power supply is not switched on	➔ Switch on power supply
Thermal switch or pump electronics have tripped	<ul style="list-style-type: none"> ➔ Disconnect pump from the mains ➔ Allow pump to cool ➔ Identify and eliminate cause of overheating/overload
Connections or hoses are blocked	<ul style="list-style-type: none"> ➔ Check connections and hoses ➔ Remove blockage
External valve is closed or filter is clogged	➔ Check external valves and filters
Diaphragm, anchor valves or seals are worn.	➔ Replace diaphragm, anchor valves and seals (see Chapter 8.3)

Tab. 13

Pump is not priming	
Possible cause	Remedy
Suction side of pump not connected	➔ Connect the suction side of the pump
Liquid in the container is too low	➔ Fill container
Hose connections are not leak-tight	➔ Secure transition joints between hose and connections with clamps or other clamping elements
Peripheral valve is closed or filter is clogged	<ul style="list-style-type: none"> ➔ Open the peripheral valve ➔ Clean filter
Pump head is filled with gas. The system is unable to handle the pressure on the pressure side	➔ Reduce pressure at pressure side
Particles in the pump	➔ Clean the pump head (see Chapter 8.2)
The pump parts are not resistant to the medium to be transferred	➔ Replace the pump head with a compatible version
Incorrect interchange of pressure and suction line connections	➔ Remove pressure and suction lines and reconnect correctly

Tab. 14

Flow rate, suction head or pressure head is too low	
The pump does not achieve the performance stated in the technical data or on the data sheet.	
Possible cause	Remedy
Components in the system connected to the suction and pressure sides, such as hoses, valves or filters, are causing too much resistance	➔ Modify installation, check the cross-sections of components
Hose connections are not leak-tight	➔ Secure transition joints between hose and hose connections with clamps or clamping elements
Particles in the pump	➔ Clean the pump head, install suction-side filter if required (see Chapter 8.2)
Viscosity of the transferred medium is too high	➔ Contact KNF
Incorrect interchange of pressure and suction line connections	➔ Remove pressure and suction lines and reconnect correctly
The pump parts are not resistant to the medium to be transferred	➔ Replace the pump head with a compatible version

Tab. 10

Fault cannot be rectified

If you are unable to identify any of the above causes, please send the pump to KNF customer service (see address on last page).

1. Flush the pump to clear the pump head of any hazardous or aggressive liquids (see Chapter 8.2.1).
2. Dismantle the pump.
3. Clean the pump (see Chapter 8.2.2).
4. Send the pump, with completed decontamination declaration (see Chapter 10), to KNF customer service stating the nature of the transferred medium.

10. Accessories

The following filters are available:

Type	Material	Mesh size	Max. flow volume (liquid)	Connections	Order No.
FS 60 T	PVDF	70 µm	600 ml/ min	UNF 1/4"- 28	165210
FS 60 X	PEEK	35 µm	600 ml/ min	UNF 1/4"- 28	165212
FS 25 T	PVDF	70 µm	250 ml/ min	for hose ID 3.2 / 4 mm	165211
FS 25 X	PEEK	35 µm	250 ml/ min	for hose ID 3.2 / 4 mm	165213

Tab. 16

i Please contact your local KNF partner for further information (www.knf.com).

11. Return of the pump

i KNF undertakes to repair the pump only under the condition that the customer provides a certificate of the pumped medium and cleaning of the pump. For this purpose, please follow the instructions on www.knf.com/repairs.

Please contact your KNF sales representative directly if you need additional support for your return service.

KNF worldwide

Please find your local KNF partners at: www.knf.com

