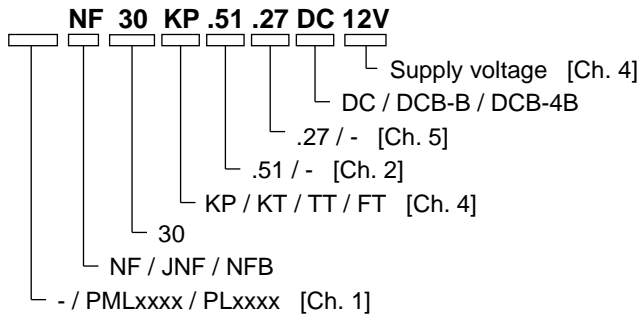


DIAPHRAGM LIQUID PUMP

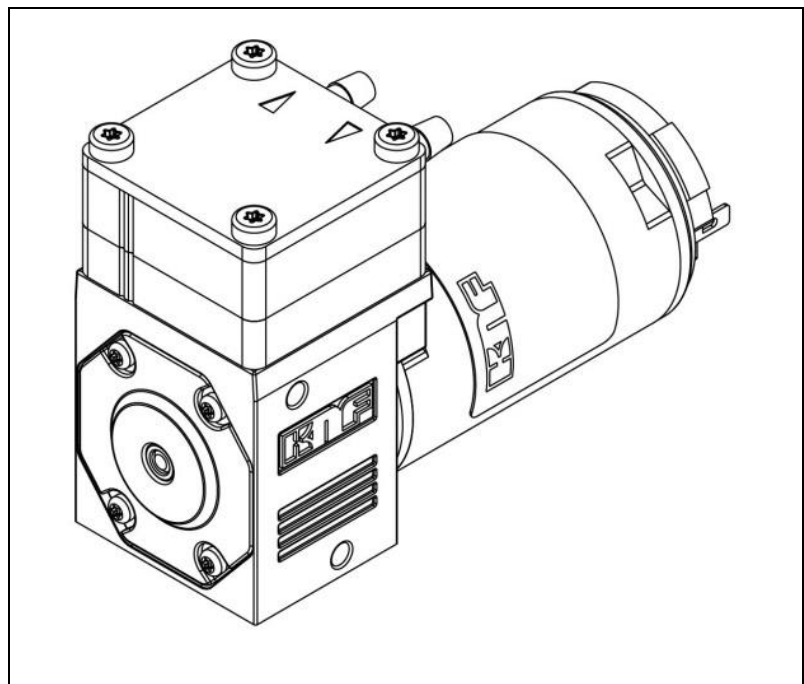
NF 30, NFB 30



Operating and Installation Instructions

Read and observe these operating and installation instructions!

An additional letter prefixing the NF model code is a country-specific designation, with no technical relevance.



KNF Flodos AG
 Wassermatte 2
 6210 Sursee, Switzerland
 Tel. +41 (0)41 925 00 25
 Fax +41 (0)41 925 00 35
 www.knf.com
 info.flodos@knf.com

Contents

Page

1. About this document.....	2
2. Use	3
3. Safety	5
4. Technical data	7
5. Assembly and function	10
6. Installation and connection.....	11
7. Operation.....	17
8. Servicing.....	21
9. Troubleshooting.....	25
10. Return of the pump.....	27

1. About this document

1.1. Use of the operating and installation instructions

The operating and installation instructions are part of the pump.

- ➔ Pass on the operating and installation instructions to the next owner.

Project pumps

Customer-specific project pumps (pump models which begin with "PL" or "PML") may differ from the operating and installation instructions.

- ➔ In the case of project pumps, take note of any additionally agreed specifications.

1.2. Symbols and markings

Warning



WARNING

This symbol indicates a potential danger.

It also indicates the possible consequences of failure to observe the warning. The signal word (i.e. "Warning") indicates the level of danger.

- ➔ This specifies measures for avoiding the danger and the consequences of failure to implement these measures.

Danger levels

Signal word	Meaning	Consequences if not observed
DANGER	warns of immediate danger	Death or serious injuries and/or serious material damage are the consequence.
WARNING	warns of possible danger	Death or serious injuries and/or serious material damage are possible.
CAUTION	warns of a possibly dangerous situation	Minor injuries or material damage are possible.

Tab. 1

Other information and symbols

- ➔ This indicates an activity (step) that needs to be carried out.
 1. This indicates the first step of an activity to be carried out. Any additional steps required are consecutively numbered.

i This symbol refers to important information.

2. Use

2.1. Proper use

The pumps are intended for transferring and metering liquids.

Owner's responsibility

Operating parameters and conditions

Only install and operate the pumps under the operating parameters and conditions described in Chapter 4, Technical data.

The pumps may be operated only when fully assembled.

Requirements for transferred medium

Before transferring or metering a medium, check that it can be transferred without risk in the specific application case.

Before using a medium, check the compatibility of the materials of the pump head, pump housing, diaphragm and valves with the medium.

The temperature of the medium must lie within the permissible temperature range (see Chapter 4).

The media should not contain particles as these can prevent the pump from working correctly. If this cannot be guaranteed, a filter < 100 µm with sufficiently large filter area must be used upstream of the pump.

.51* version – version with food grade approval

The .51 versions of our diaphragm liquid pump range have been certified by NSF according to the standard NSF/ANSI 169 and are therefore suitable for use with foodstuffs without any restrictions.

All materials used have been checked through a series of toxicological tests. In order to ensure that the food grade quality is maintained, NSF will carry out a yearly audit checking our certified products.

Only the pumps marked with ".51" are NSF-certified and contain a defined material combination that also has a FDA certificate of conformity.

NSF: National Sanitary Foundation

FDA: Food and Drug Administration

ANSI: American National Standard Institute

** Pumps with other customer-specific certified material combinations are available on request.*

- ➔ All certified diaphragm liquid pumps are clearly marked with “.51” in the type designation along with the NSF-logo on the type plate. If either or both of these markings are missing, the pump is not certified.
- ➔ Because the cleaning requirements of the diaphragm liquid pumps depend on the application, KNF is unable to guarantee cleaning options. The responsibility for cleaning the pump(s) therefore lies with the user. While the NSF/ANSI 169 standard regulates OEM products, it does not define cleaning methods for specific OEM products.
- ➔ All parts in contact with the medium can be replaced as spare parts without losing the certification. Component parts cannot be traded as certified parts. When replacing parts/assemblies only use original KNF parts.

2.2. Improper use

The pumps may not be operated in an explosive atmosphere. For special modifications outside the standard technical specifications, please contact a KNF pump specialist.

3. Safety

i Note the safety precautions in Chapters 6. *Installation and connection*, and 7. *Operation*.

The pumps are built according to the generally recognized rules of technology and in accordance with the pertinent occupational safety and accident prevention regulations. Nevertheless, dangers can result during their use which lead to injuries to the user or others, or to damage to the pump or other property.

Only use the pumps in perfect working order and in accordance with their intended use. Always ensure adherence to the operating and installation instructions and work in a safety-conscious manner.

Personnel	<p>Make sure that only trained and instructed personnel or specially trained personnel work on the pumps. This especially applies to assembly, connection and servicing work.</p> <p>Make sure that all personnel have read and understood the operating and installation instructions, and in particular the "Safety" chapter.</p>
Working in a safety-conscious manner	Always ensure adherence to all pertinent accident prevention and safety regulations when working on and operating the pump.
Handling dangerous media	Always observe the safety regulations when handling dangerous media.
Notes	Always ensure adherence to all information stickers on the pumps, such as flow direction arrows and type plates, and keep stickers in legible condition.
Environmental protection	All replacement parts should be properly stored and disposed of in accordance with the applicable environmental protection regulations. Ensure adherence to the pertinent national and international regulations. This especially applies to parts contaminated with toxic substances.
Disposal	<p>Dispose of all packaging in an environmentally appropriate manner. The packaging materials are recyclable.</p> <p>Ensure that the pump is disposed of in an environmentally appropriate manner at the end of its useful life. Use appropriate waste collection systems for the disposal of end-of-life equipment. Used pumps contain valuable recyclable materials.</p>



EU directives/standards	<p>The pumps are in accordance with the requirements of the guidelines 2011/65/EU (ROHS2)</p> <p>As defined in the Machinery Directive 2006/42/EC, pumps are partly completed machines and not ready-for-use, the overall equipment must be made to fully conform with the requirements of the Directive before being brought into service. Always ensure implementation and enforcement of the basic requirements of the Machinery Directive 2006/42/EC according to Appendix I (General Principles).</p> <p>The following harmonised standards are met:</p> <p>NF 30 DC</p> <ul style="list-style-type: none">▪ EN 55014-1 <p>NF 30 DCB-B / DCB-4B</p> <ul style="list-style-type: none">▪ IEC/EN 61000-6-2▪ IEC/EN 61000-6-3 <p>NFB 30 DCB-B / DCB-4B</p> <ul style="list-style-type: none">▪ IEC/EN 61000-6-2▪ IEC/EN 61000-6-3
Customer service and repairs	All repairs to the pump(s) must be carried out by the relevant KNF Customer Service team.

4. Technical data

Pump materials

The pump type **KP** stands for:

Assembly	Material ¹⁾
Pump head *	PP
Valve plate	EPDM
Diaphragm	EPDM
Diaphragm .27	EPDM

Tab. 2

¹⁾ according to DIN ISO 1629 and 1043.1

The pump type **KT** stands for:

Assembly	Material ¹⁾
Pump head *	PP
Valve plate	FFKM
Diaphragm	PTFE
Diaphragm .27	FFKM

Tab. 3

¹⁾ according to DIN ISO 1629 and 1043.1

The pump type **TT** stands for:

Assembly	Material ¹⁾
Pump head *	PVDF
Valve plate	FFKM
Diaphragm	PTFE
Diaphragm .27	FFKM

Tab. 4

The pump type **FT** stands for:

Assembly	Material ¹⁾
Pump head *	PTFE
Valve plate	FFKM
Diaphragm	PTFE

Tab. 5

¹⁾ according to DIN ISO 1629 and 1043

* The pump head (Fig. 1) comprises a connecting plate and an intermediate plate

Hydraulic ratings

Parameter	Value
Flow rate NF 30 [l/min] ^{1), 2)}	≥ 0.3
Flow rate NFB 30 [l/min] ^{1), 2)}	≥ 2 x 0.3
Permitted pressure [bar above atmospheric]	1
Suction head [mWG] ³⁾	6

Tab. 6

¹⁾ Measured with water at 20°C / at atmospheric pressure

²⁾ Flow rates may vary from the values shown depending on fluid viscosity, pump head material and the hoses / hose connectors used.

³⁾ For version with PTFE diaphragm max. 5 mWG

Hydraulic connections

Parameter	Value
Recommended hose size ID [mm]	4

Tab. 7

Specifications NF 30 DC

Motor voltage	12V	24V
Power consumption [W]	8.3	8.6
Max. current at max. load [A]	0.69	0.36
Protection class [-]	IP 00	
Weight ¹⁾ [g]	180	

Tab. 8

Specifications NF 30 DCB-B / DCB-4B

Motor variant	DCB-B	DCB-B	DCB-4B
Supply voltage [V]	12	24	10..26.4
Power consumption [W]	7	7.7	7.4
Max. current at max. load [A]	0.58	0.32	0.68..0.28
Protection class [-]	IP 30		
Weight ¹⁾ [g]	210		

Tab. 9

Specifications NFB 30 DCB-B / DCB-4B

Motor variant	DCB-B	DCB-B	DCB-4B
Supply voltage [V]	12	24	10..26.4
Power consumption [W]	10.9	11.5	12
Max. current at max. load [A]	0.91	0.48	1.2..0.48
Protection class [-]	IP 30		
Weight ¹⁾ [g]	250		

Tab. 10

Various parameters

Parameter	Value
Permissible ambient temperature range [°C]	+ 5 to + 40
Permissible media temperature range [°C]	+ 5 to + 80
Permissible kinematic viscosity of the media [cSt]	≤ 150

Tab. 11

5. Assembly and function

Assembly

- 1 Outlet
- 2 Inlet
- 3 Head plate
- 4 Connecting plate
- 5 Intermediate plate
- 6 Motor

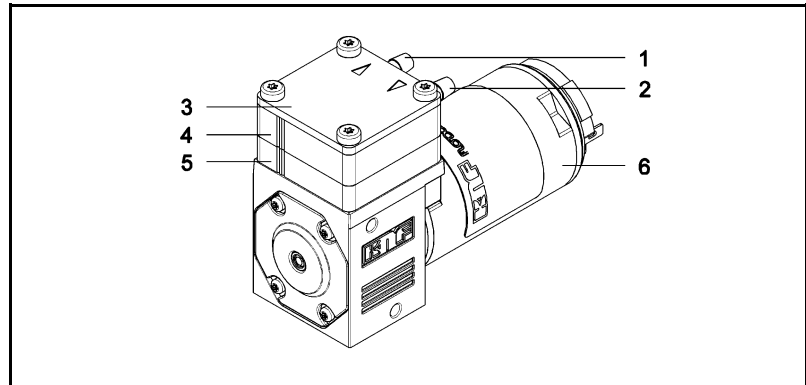


Fig. 1 Diaphragm liquid pump

- 1 Exhaust valve
- 2 Inlet valve
- 3 Working chamber
- 4 Diaphragm
- 5 Eccentric
- 6 Connecting rod
- 7 Pump drive

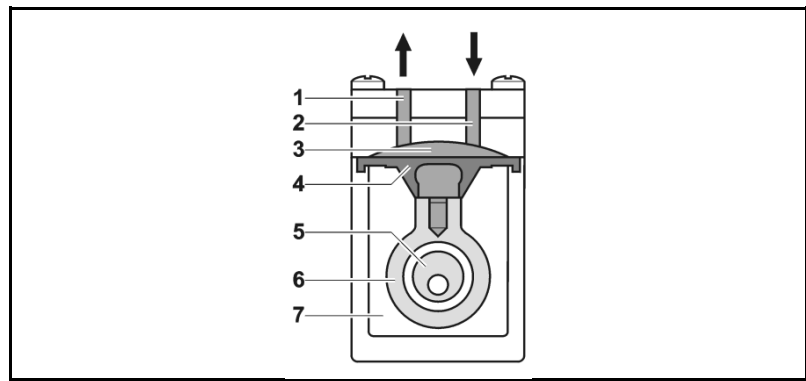


Fig. 2: Operating principle

Diaphragm liquid pumps are based on reciprocating displacement pump technology. An elastic diaphragm (4) is moved up and down by the eccentric (5) and the connecting rod (6). During the down stroke, the diaphragm sucks in the medium through the inlet valve (2). During the up stroke, it forces medium out of the pump head through the exhaust valve (1). The diaphragm hermetically seals off the working chamber (3) from the pump drive (7).

NF 30 version (specified flow rate)

This pump type represents this product in its simplest form and delivers media at the specified flow rate.

NF 30 .27 version (specified flow rate with overpressure limiting)

If the diaphragm liquid pump is operating against a closed system, the delivery pressure quickly exceeds the maximum permissible values. To prevent this happening, an overpressure relief is integrated in the top part of the pump head. If the pressure exceeds the variable limit range (min. 0.5 to max. 1.0 barg), the valve opens and the liquid circulates from the pressure side to the suction side via an internal bypass system. This prevents any further rise in pressure.

6. Installation and connection

Only install and operate the pumps under the operating parameters and conditions described in Chapter 4, Technical data.

Observe the safety notes (see Chapter 3).

6.1. Installation

→ Before installation, store the pump at the installation location to bring it up to ambient temperature.

Mounting dimensions

→ Mounting dimensions (see Fig. 3 to 12)

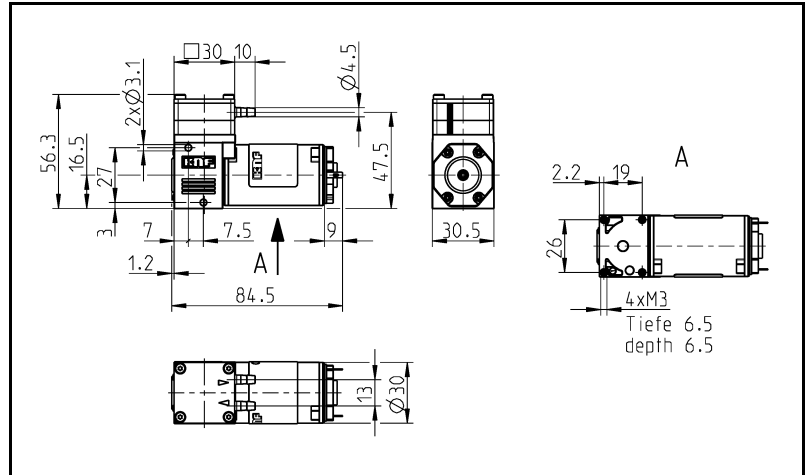


Fig. 3: Mounting dimensions NF 30 DC

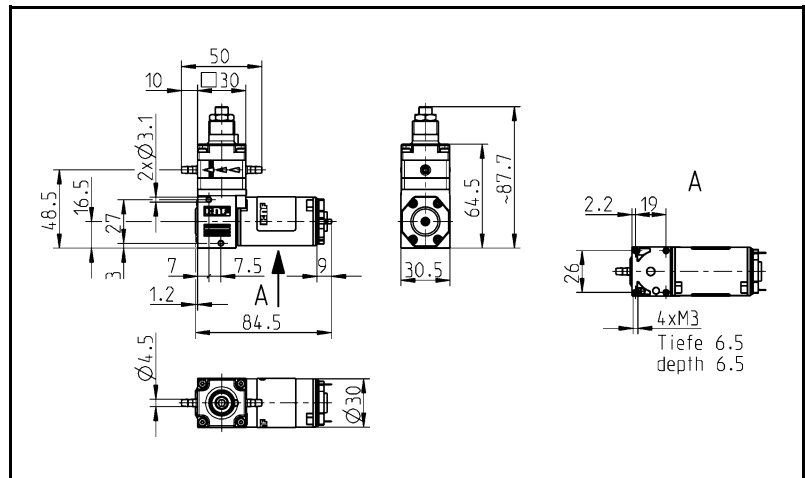


Fig. 4: Mounting dimensions NF 30.27 DC

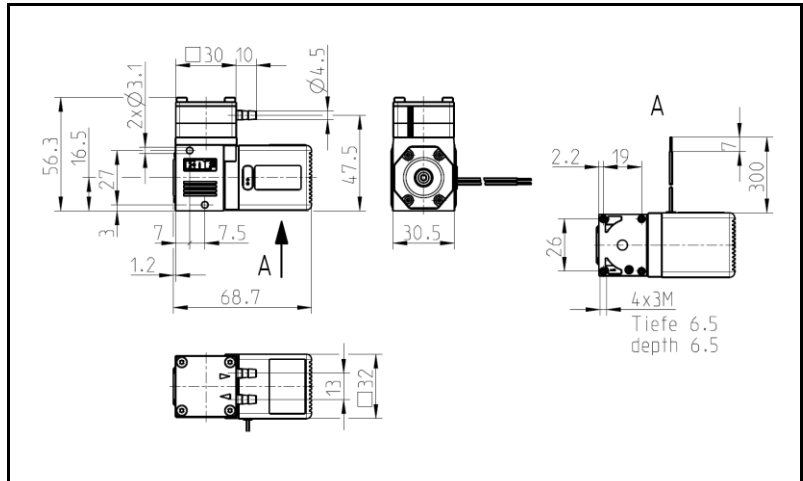


Fig. 5: Mounting dimensions NF 30 DCB-B

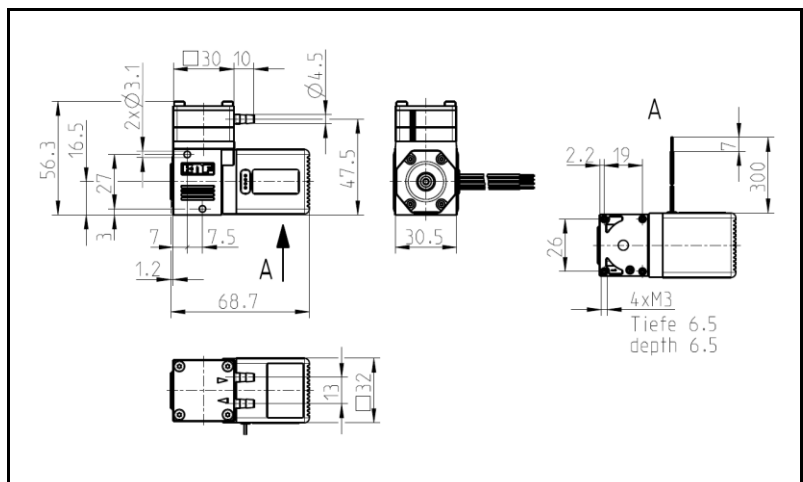


Fig. 6: Mounting dimensions NF 30 DCB-4B

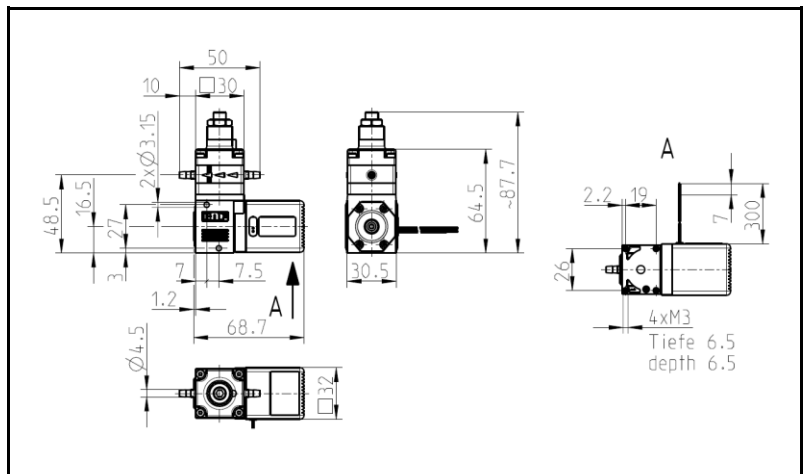


Fig. 7: Mounting dimensions NF 30.27 DCB-B

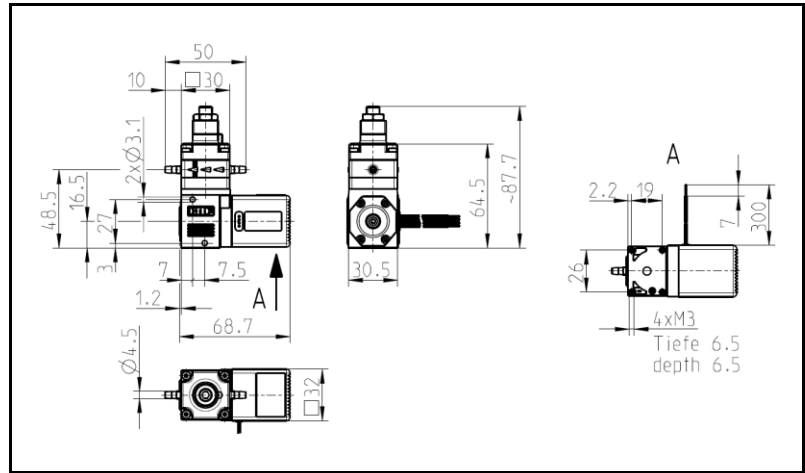


Fig. 8: Mounting dimensions NF 30.27 DCB-4B

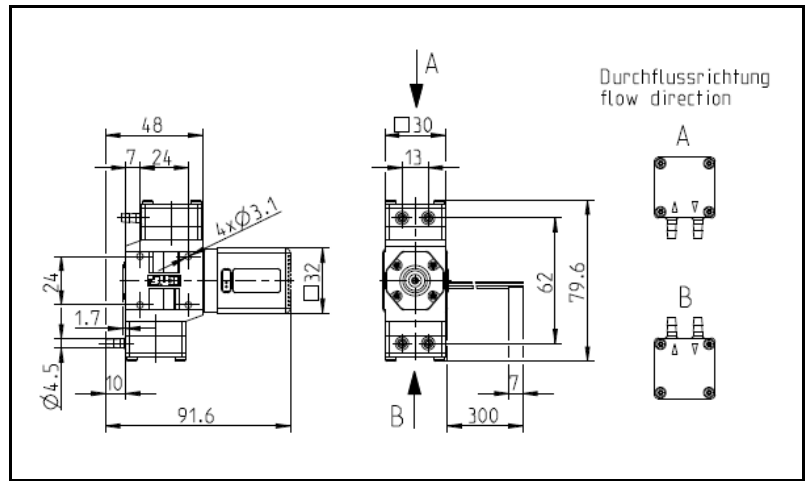


Fig. 9: Mounting dimensions NFB 30 DCB-B

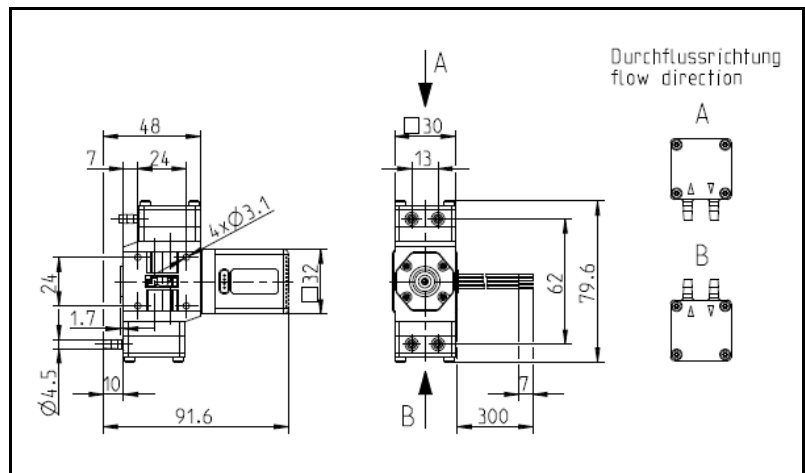


Fig. 10: Mounting dimensions NFB 30 DCB-4B

- Cooling air supply → For pumps with fan: mount the pump so that the fan of the motor can suck in sufficient cooling air.
- Installation location → Make sure that the installation location is dry and the pump is protected against rain, splashes, hose and drip water.
- Protect the pump against dust.
- Protect the pump against vibrations and jolts.
- Mounting orientation → Generally speaking, the pump can be mounted in any orientation. The venting and accuracy of the pump is optimal if installed as shown in the illustration (Fig. 12).

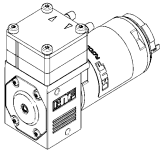


Fig. 11: Optimal mounting orientation / horizontal

- Decoupling → KNF recommends mechanically decoupling the pump from the pipework system, e.g. by using flexible hoses or pipes. This prevents any oscillations of the pump being transferred to the system.

Touch and foreign object protection

For pumps with alternating current motors:



WARNING

Danger of injury during operation

- Take protective measures against touching parts which are energised (live), such as electrical connections or windings.
- Take protective measures against touching moving parts (e.g. fan).

Danger of damaging the pump during operation

- Take protective measures to ensure that no foreign objects can get into the pump or penetrate the motor (see protection class).

6.2. Electrical connection

For pumps with alternating current motors:



DANGER

Risk of electric shock, danger of death

- Pump should only be connected by a specialist.
- Only connect the pump when the power supply is turned off.

For pumps with direct current motors:

- Pump should only be connected by a specialist.
- Only connect the pump when the power supply is turned off.
- All electrical connection work must adhere to the pertinent guidelines, regulations and technical standards.

Connecting the pump

1. Make sure that the power supply data match the data on the motor type plate. The current consumption can be found on the type plate.
2. Connect the motor cables. Electrical data Chapter 4.

i Always check polarity of cables.

For DC motors:

red motor lead: +

black motor lead: -

In the case of brushless DC motors:

incorrect polarity may damage to the electronics.

If using AC motors, the power supply must not deviate more than a maximum of +/- 10 % from the specifications on the type plate.

Connected
components

Hoses

6.3. Hydraulic connection

- ➔ Only connect components to the pump that are designed to handle the hydraulic data of the pump (see Chapter 4, Technical data).
- ➔ Only use hoses that are suitable for the maximum operating pressure of the pump (see Chapter 4).
- ➔ Only use hoses that are chemically resistant to the liquids being pumped.

6.3.1. Connecting the pump

i Arrows on the pump head indicate the flow direction.

1. Remove the protective caps from the connections.
2. Connect the inlet and outlet lines.

i Keep the inlet line as short as possible in order to keep the priming process as short as possible.

3. If the pump is used to build up pressure make sure that all transition joints between hose and pump are secure in order to ensure that the hoses cannot come off.

Check that the hoses and transition joints are fitted correctly

4. and securely.
5. Check that the system is leak-tight.

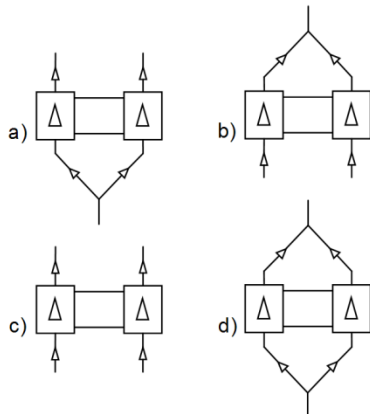


Fig. 12: Hose connection options for NFB-versions



CAUTION

In the case of NFB-versions, the use of .27 versions may affect technical characteristics (see Fig. 14, Hose connection options b) and d)).

7. Operation

- The pumps should only be used under the operating parameters/conditions described in Chapter 4, Technical data.
- Ensure that the pumps are being used correctly (see Section 2.1).
- Improper use of the pumps must be prevented (see Section 2.2).
- Observe the safety notes (see Chapter 3).
- Pumps are components intended to be incorporated into another machine. The machine/equipment in which the pumps are installed must be made to fully comply with the pertinent regulations before being put into operation.



CAUTION

Risk of burning
The drive heats up.

- Avoid contact with the drive.
- Avoid contact with flammable materials.



WARNING

Danger of bursting of the fluid system due to overpressure.

The pump builds up pressure. A closed system can cause the max. permitted operating pressure to be exceeded. This can cause injuries or damage to the pump and the system.

- Avoid operation against a closed system.
- Only use wetted parts that are rated for at least the operating pressure of the pump.
- If necessary, limit the maximum system pressure by suitable measures.

i Excessive pressures and its inherent dangers can be prevented by using a bypass system with a pressure relief valve between the pressure and suction side of the pump. Further information is available from your KNF adviser (Telephone number: see first page).

Pump standstill → If the pump stops running, reduce the pressure in the system until it is at normal atmospheric pressure.

For pumps with thermal switch or electronic overload protection:

**WARNING**

Risk of physical injury and damage to the pump due to automatic start

If the pump overheats and the thermal switch / electronics stops pump operation, the pumps will restart automatically as soon as they have had time to cool down.

→ Take steps to ensure that this cannot produce a hazardous situation.

Switching the pumps on and off

Adjusting and controlling the motor speed

The motor speed of the pump, and thus the flow rate, is adjustable and can also be regulated to some extent.

For more details, see Chapter 4, Technical data.

Impulse operation

Duty cycle / impulse operation

KNF pumps are designed for continuous operation.

Short start and stop cycles may adversely affect the service life of the brushed motors.

i If the pump is operated with short cycles in your application, please contact a KNF pump specialist for further information (Telephone number: see first page).

Turning the pump on

→ In order to guarantee that the pump can start every time it is advisable to reduce the back pressure to an acceptable level. This is also the case if there is a short power cut.

i For more specific information contact the KNF specialist (Telephone number: see first page).

Turning the pump off

→ KNF recommends: if pumping aggressive liquids, the pump should be rinsed thoroughly prior to switch off (see Section 8.2.1), as this will help to lengthen the service life of the diaphragm.

→ Ensure that the system is subject to normal atmospheric pressure (release the hydraulic pressure).

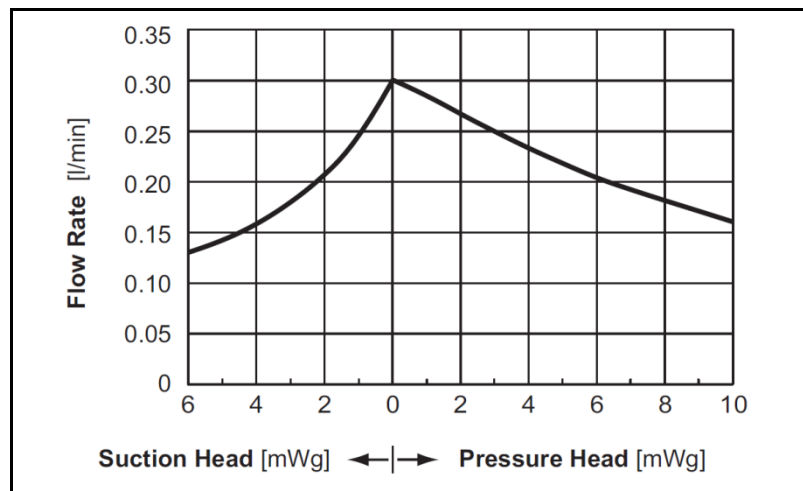
Flow rate NF 30

Fig. 13: Flow rate of pumps NF 30 DC and NF 30.27 DC

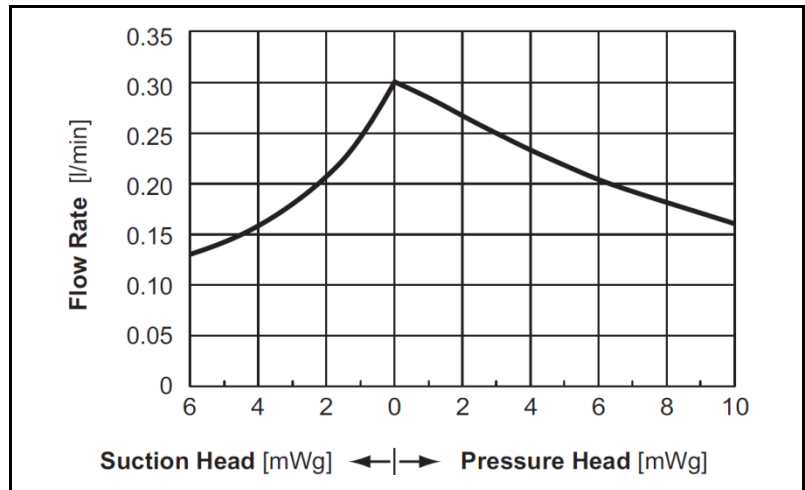


Fig. 14: Flow rate of pumps NF 30 DCB-B / DCB-4B and NF 30.27 DCB-B / DCB-4B

Flow rate NFB 30

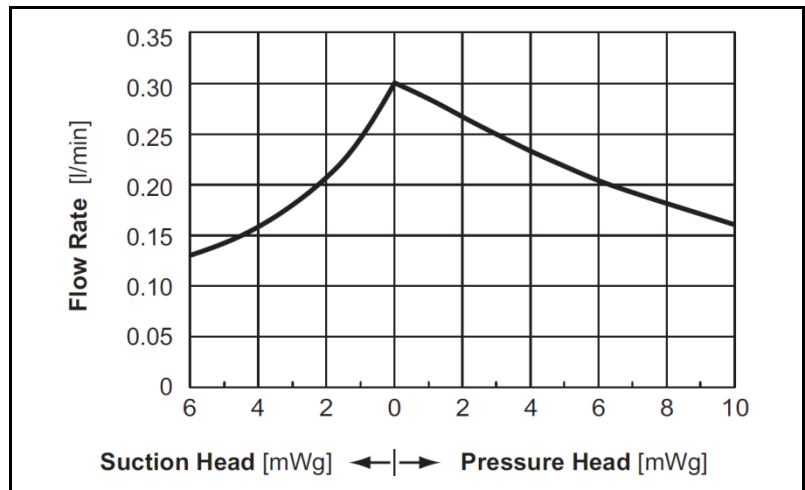


Fig. 15: Flow rate of pump NFB 30 DCB-B / DCB-4B

8. Servicing

8.1. Servicing schedule

Component	Servicing interval
Pump	- Regular inspection for external damage or leaks
Pump head	- Clean if the flow rate decreases, the pump does not work or no vacuum is created (Section 8.2)
Diaphragm, valve plates and seals	- Change as soon as pumping capacity decreases, preferably sooner

Tab. 12

8.2. Cleaning

Information on procedure



WARNING

Health hazard due to dangerous substances in the pump!

Depending on the substance transferred, risk of caustic burns or poisoning.

- Wear protective clothing if necessary, e.g. protective gloves.
- Rinse the pump with a neutral liquid and pump empty.

8.2.1. Flushing the pump

- If pumping aggressive media, KNF recommends flushing the pump with air under atmospheric conditions for several minutes prior to switch off (if necessary for safety reasons: use an inert gas). This will extend the service life of the diaphragm.

8.2.2. Cleaning the pump

- Where possible, wipe the components with a soft dry cloth. Do not use cleaning solvents as these may corrode plastic parts.
- If there is compressed air available, blow off the separate parts.

Prior requirements

- Pump must be switched off and mains plug removed from the socket.
- The pump must be free of any hazardous substances.
- Hoses must be disconnected from the pump head.
- We recommend replacing the diaphragm when the head parts are removed.

Tools

Qty.	Tool
1	Torxplus 10 IP screwdriver

Tab. 13

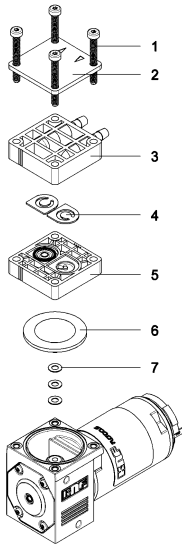


Fig. 16: NF30

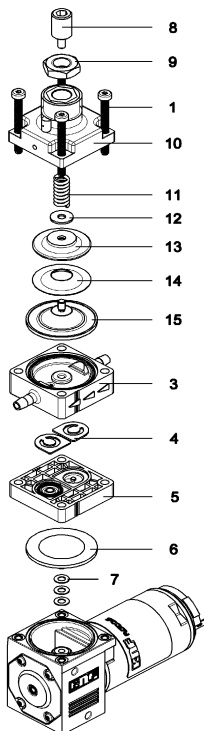


Fig. 17: NF30.27

- 1 Head screw
- 2 Head plate
- 3 Connecting plate
- 4 Valve plate
- 5 Intermediate plate
- 6 Diaphragm
- 7 Washer
- 8 Setscrew.27
- 9 Hexagon nut.27
- 10 Head plate.27
- 11 Compression spring.27
- 12 Washer.27
- 13 Support.27
- 14 Sliding disk.27
- 15 Diaphragm.27

Dismantling the pump heads

1. Loosen the four head screws (1) and remove the entire head.

Removing the valves and seals

2. Remove the connecting plate (3) from the intermediate plate (5).
3. Take the valve plate (4) out of the intermediate plate (5).
4. For NF 30.27 pumps only:
remove the diaphragm.27 (15), sliding disk.27 (14), support.27 (13), washer.27 (12) and compression spring.27 (11) from the connecting plate (3).
5. Carefully grip the diaphragm (6) and remove by turning anti-clockwise. Remove the washers (7) and make sure that no washers fall into the pump housing.

We recommend replacing the diaphragm (6).

Clean the parts

6. Clean the diaphragm (6), diaphragm.27 (15), sliding disk.27 (14), support.27 (13), washer.27 (12), compression spring.27 (11), valve plate (4), intermediate plate (5) and connecting plate (3) using a cloth and then blow off with compressed air.

Mounting the diaphragm

7. Place the same number of washers (7) on the new diaphragm (6) as were on the old diaphragm thread. Make sure that no washers fall into the pump housing. Screw the diaphragm (6) securely back into the connecting rod.
9. By lightly pressing on the diaphragm push the ridge on the underside of the diaphragm into the groove of the housing.

Mounting the valve plates

10. Insert the "dust free" valve plates (4) in the intermediate plate (5) making sure they are in the correct position.

Mounting the pump head

- ➔ The method of assembly will depend on the pump type. For this reason, please proceed with the section that corresponds to the pump type you are using (**NF 30 and NF 30 KP.51 version or NF 30.27 version**).
- ➔ Re-connect the hoses to the pump head.

NF 30 and NF 30 KP.51 version

1. The visible lines on the intermediate plate (5) and the connecting plate (3) must be in line with each other.
2. The head plate (2) must be positioned so that the flow direction arrows coincide with the connections on the connecting plate (3).
3. Insert the four head screws (1) in the through holes of the pump head.
4. Place the pump head onto the pump housing and alternately tighten the four head screws (1).

NF 30.27 version

1. Place the diaphragm.27 (15) in the centre of the connecting plate (3).
 2. Then place the sliding disk.27 (14), support.27 (13), and washer.27 (12) on the diaphragm.27 (15).
 3. Place the compression spring.27 (11) over the thread of the diaphragm.27 (15). Then add the washer.27 (12).
 4. Carefully place the head plate.27 (10) with the setscrew.27 (8) and the hexagon nut.27 (9) over the whole unit.
 5. The visible lines on the intermediate plate (5) and the connecting plate (3) must be in line with each other.
 6. You can choose any position (direction of rotation) for the head plate.27 (10).
 7. Insert the four head screws (1) in the through holes of the pump head.
 8. Place the pump head onto the pump housing and alternately tighten the four head screws (1).
- While the above actions should not alter the set pressure of the overflow valve, if you find the setting has changed after assembly, you can modify the value in the permissible range of the pump according to the instructions of Section 8.4 and, if necessary, reset the peripheral installations.

8.3. Replacing parts

Same procedure as in Section 8.2, "Cleaning" – with the exception of step 6:

Instead of cleaning the diaphragm (6), diaphragm.27 (15), sliding disk.27 (14), support.27 (13), washer.27 (12), compression spring.27 (11), valve plate (4), intermediate plate (5) and connecting plate (3), these components must be replaced.

8.4. Adjusting the overflow

1. Test set-up/instrumentation as shown in the diagram.

Test set-up for overflow

Make sure that the container (a), pump (b), pressure gauge (c) and valve (d) are as level as possible (+/- 15 cm)

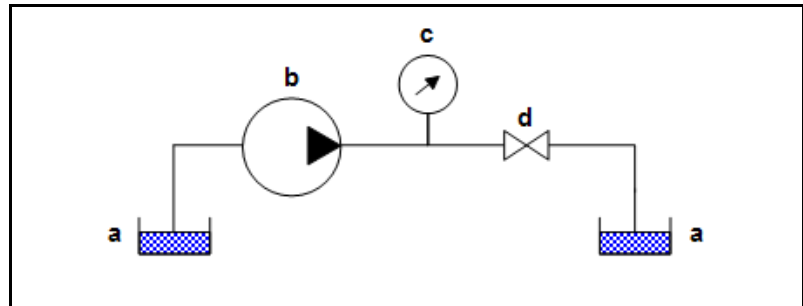


Fig. 18: Test set-up for overflow

2. Switch on the pump and run until there are no air bubbles in the system.
3. Close the valve downstream of the pressure gauge and check the overflow pressure at the gauge.
4. Undo the hexagon nut.27 (9).
5. To reduce the pressure, turn the setscrew.27 (8) anti-clockwise, to increase the pressure, turn it clockwise.
6. Using the hexagon nut.27 (9) fix the setscrew.27 (8) in the required position.

9. Troubleshooting

For pumps with alternating current motors:



Risk of electric shock, danger of death

→ Before working on the pump disconnect the pump from the power supply.

DANGER

→ Ensure that the pump is de-energised.

Pump does not work	
Cause	Fault remedy
Pump not connected to mains power supply.	→ Connect pump to mains supply.
Power supply is not switched on.	→ Switch on power supply.
Thermal switch or pump electronics have responded.	<ul style="list-style-type: none"> → Disconnect pump from mains power supply. → Allow pump to cool. → Identify and eliminate cause of overheating/overload.
Connections or pipes are blocked.	<ul style="list-style-type: none"> → Check pipes and connections. → Remove blockage.
External valve is closed or filter is blocked.	→ Check external valves and filters.
Diaphragm or valves are worn out.	→ Replace diaphragm and valve plate (see Section 8.3).

Tab. 14

Pump is not priming	
Cause	Fault remedy
Suction side of pump not connected.	→ Connect the suction side of the pump.
Liquid in the container is too low.	→ Fill container.
Hose connections are not leak-tight.	→ Secure transition joints between hose and connections with clamps or clamping elements.
System valve is closed or filter is blocked.	<ul style="list-style-type: none"> → Open the valve. → Clean filter.
Pump head is filled with gas. The system is unable to handle the pressure on the pressure side.	→ Reduce pressure on pressure side.
Particles in the pump.	→ Clean the pump head (see Section 8.2).
The head parts are not media-resistant.	→ Replace the pump head with a compatible version.
Incorrect interchange of outlet and inlet line connections.	→ Remove outlet and inlet lines and re-connect correctly.

Tab. 15

Flow rate, suction head or pressure head is too low	
The pump does not achieve the technical performance data stated on the data sheet.	
Cause	Fault remedy
Components in the system connected to the suction and pressure sides, such as hoses, valves or filters, are causing too much resistance.	➔ Modify installation, check the cross-section of components.
Hose connections are not leak-tight.	➔ Secure transition joints between hose and hose connections with clamps or clamping elements
Particles in the pump.	➔ Clean the pump head, install suction-side filter if required (see Section 8.2).
Viscosity of the liquid is too high.	➔ Contact KNF.
Incorrect interchange of outlet and inlet line connections .	➔ Remove outlet and inlet lines and re-connect correctly.
The head parts are not media-resistant.	➔ Replace the pump head with a compatible version.

Tab. 16

Fault cannot be rectified

If you are unable to identify any of the above causes, please send the pump to KNF customer services (see address on last page).

1. Flush the pump to clear the pump head of any hazardous or aggressive fluids (see Section 8.2.1).
2. Dismantle the pump.
3. Clean the pump (see Section 8.2.2).
4. Send the pump, with completed decontamination statement (see Chapter 10), to KNF customer services stating the nature of the pumped medium.

10. Return of the pump

i KNF undertakes to repair the pump only under the condition that the customer provides a certificate of the pumped medium and cleaning of the pump. For this purpose, please follow the instructions on www.knf.com/repairs.

Please contact your KNF sales representative directly if you need additional support for your return service.

KNF worldwide

Please find your local KNF partners at: www.knf.com

