

OEM

**MGP75-__-XT
TRANSLATION OF THE ORIGINAL OPERATING AND
INSTALLATION INSTRUCTIONS
ENGLISH**

DIAPHRAGM PUMPS

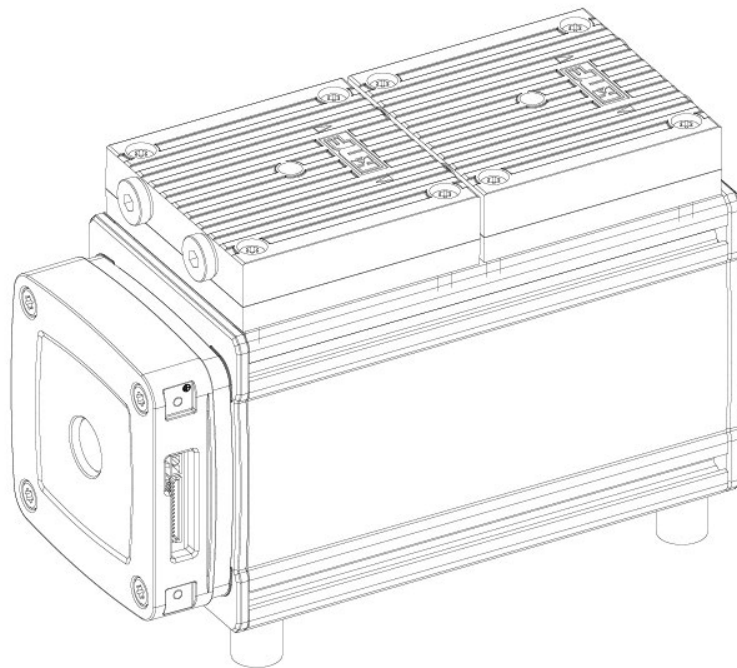

*Please note!
Before operating the pump and accessories, read the operating and installation instructions and observe the safety instructions!*

KNF Neuberger GmbH
Alter Weg 3
79112 Freiburg
Germany
Tel. +49 (0)7664 / 5909-0
Fax +49 (0)7664 / 5909-99

E-mail: info@knf.de
www.knf.de

Contents	Page
1. About this document	3
2. Safety	5
3. Technical data	10
4. Product description	13
5. Transport	15
6. Installation and connection	17
7. Operation	23
8. Maintenance	26
9. Spare parts and accessories	38
10. Rectifying faults	39
11. Returns	42
12. Appendix: MO motors	43

1. About this document

1.1. Using the operating and installation instructions

The operating and installation instructions are part of the pump.

- In the event of uncertainties with regard to the content of the operating and installation instructions, please contact the manufacturer (contact data: see www.knf.com). Please have the type and serial number of the pump ready.
- Read the operating and installation instructions before you commission the pump.
- Keep the operating and installation instructions within reach at all times.
- Give the operating and installation instructions to the next owner.

Project pumps For customer-specific project pumps (pump types that begin with "PJ" or "PM"), there may be deviations from the operating and installation instructions.

- For project pumps, also observe the agreed specifications.

Optional contents Project-specific options may be included in the operating and installation instructions. These are marked with "Optional". It is also possible that project-specific deviations are not included in the operating and installation instructions.

1.2. Exclusion of liability

The manufacturer accepts no liability for damages and failures

- due to non-compliance with the operating and installation instructions.
- due to changes or modifications to the device or improper handling.
- due to the use of impermissible spare parts or accessory parts.

1.3. Symbols and markings

Warning notice



WARNING

A notice that warns you of danger is located here.

Possible consequences of a failure to observe the warning notice are specified here. The signal word, e.g., Warning, indicates the danger level.

- Measures for avoiding the danger and its consequences are specified here.

Danger levels

Signal word	Meaning	Consequences if not observed
DANGER	warns of immediate danger	Death or serious injury or serious material damage will result.
WARNING	warns of possible danger	Death, serious injury or serious material damage are possible.
CAUTION	warns of a possibly dangerous situation	Minor injuries or material damage are possible.
NOTICE	Warns of possible material damage	Material damage is possible.

Tab. 1: Danger levels







Other information and symbols

➔ This is an activity to be carried out (a step).

1. This is the first step of an activity to be carried out. Further consecutively numbered steps follow.

i This symbol indicates important information.

Explanation of pictograms

Pictogram	Meaning
	General warning symbol
	Warning of hot surfaces
	Warning of electrical voltage
	Warning of poisonous substances
	Warning of hand injuries through crushing
	Observe the operating instructions
	General mandatory sign

Tab. 2: Explanation of pictograms

2. Safety

i Observe the warning notices in Chapters 6. Installation and connection and 7. Operation.

2.1. Personnel and target group

Personnel Ensure that only specialized personnel carry out work on the pumps. This applies, in particular, to mounting, connection and maintenance work.

Ensure that the personnel have read and understood the operating and installation instructions, particularly the Safety chapter.

Target group	Target group	Definition
	User personnel	Employee
	Specialized personnel	<p>Specialized personnel are personnel who</p> <ul style="list-style-type: none"> ▪ have relevant professional training in the field covered in the particular section of text; ▪ have current knowledge of the field covered in the particular section of text. <p>A distinction is made between the following specialized personnel: C2: Skilled worker C2-Me: Skilled worker - Mechanical fitter C2-Pi: Skilled worker - Pipeline fitter C2-EL: Skilled worker - Electrician</p>

Tab. 3: Target group

Who-does-what matrix

Lifecycle phase	User personnel	Specialized personnel
Transport		C2
Mounting		C2-Me
Connection		C2-Pi, C2-EL
Commissioning	X	C2
Operation	X	C2
Maintenance		C2-Me
Troubleshooting		C2C2-Pi, C2-EL
Disposal		C2

Tab. 4: Who-does-what matrix

2.2. Responsibility of the operator

The pumps are produced in accordance with the generally recognized rules of engineering, as well as the occupational health, safety and accident prevention regulations. Nevertheless, dangers can arise during use that can lead to injuries to the user or third parties or damage to the pump or property.

Only use the pumps in perfect operating condition, for their intended use, safely and with an awareness of the dangers and in observation of the operating and installation instructions.

The components that are to be connected to the pumps must be designed according to the pneumatic data of the pumps.

When connecting the pumps to the electrical power supply, observe the corresponding safety rules.

Make sure that no hazardous situation, physical harm or impairment of the pump can occur.

Operating parameters

Only operate and install the pump under the operating parameters and operating conditions described in Chapters 2.4. Product description and 3. Technical data.

2.3. Working in a safety conscious manner

Observe the regulations on accident prevention and safety during all work on the pumps and during operation.

Avoid contact with the pump heads and housing parts because the pump heats up during operation.

When working on the pump, make sure the pump is disconnected from the power supply and free of voltage.

When connecting the pump to the electrical power supply, observe the corresponding safety rules.

Ensure that no hazards arise from gas flowing when gas connections are open, from the effects of noise or from hot, corrosive, dangerous and environmentally hazardous gases.

Ensure that the pump installation is EMC compliant such that no hazardous situations can occur.

2.4. Operating conditions

Only use the pump in perfect operating condition, for its intended purpose, safely and aware of the dangers and in observation of the operating instructions.

Only install and operate the pumps in accordance with the operating parameters and conditions described in Chapter 3. Technical data.

Only pumps that are fully assembled and in the condition as delivered may be operated.

Make sure that the installation location is dry and that the pump is protected from rain, splash water, gushing water, dripping water and other contamination.

Check the tightness of the connections between the pipes of the application and the pump (or the connection of the pump) at regular intervals. Leaky connections carry the risk of releasing dangerous gases and vapors from the pump system.

2.5. Media

Requirements of pumped media	<p>Before pumping a medium, check whether the medium can be pumped safely in the specific use case.</p> <p>Also take note of any possible change in the state of matter (condensation, crystallization).</p> <p>Before using a medium, check the compatibility of the media-contacting components (see technical data) with the medium.</p> <p>Risk of dangerous gas mixtures during pump operation if the diaphragm ruptures: Depending on the pumped medium, a ruptured diaphragm can result in a dangerous mixture if the medium mixes with the air in the pump housing or the surroundings.</p> <p>Only transfer gases that remain stable under the pressures and temperatures that arise in the pump.</p>
Handling of hazardous media	<p>Upon rupture of the diaphragm and/or leaks, the pumped medium mixes with the air in the surroundings and/or in the pump housing.</p> <p>Make sure that a dangerous situation cannot arise as a result.</p> <p>Ensure compliance with all relevant safety regulations when pumping hazardous media</p> <p>.</p>
Handling of combustible media	<p>Note that the pump is not designed to be explosion-proof.</p> <p>Maintain the medium temperature at a safe margin below its ignition point to prevent ignition or explosion. This requirement applies under all operating conditions, including abnormal situations.</p> <p>Moreover, note that the temperature of the medium rises when the pump compresses the medium.</p> <p>Therefore, make certain that the temperature of the medium also remains sufficiently below its ignition temperature even when it is compressed to the maximum permissible operating pressure of the pump. The maximum permissible operating pressure of the pump is stated in Chapter 3. Technical data .</p> <p>Make certain that the permissible ambient temperature (see Chapter 3. Technical data) is not exceeded.</p> <p>Where applicable, also take into account external energy sources (such as radiated heat sources) that might heat the medium further.</p> <p>In case of doubt, contact KNF Customer Service.</p>

2.6. Use

2.6.1. Intended use of instrument

The pumps are intended exclusively for transferring gases and vapors.

The pumps are intended exclusively for operation in indoor environments and in non-explosive atmospheres.

2.6.2. Improper use

The pumps must not be operated in explosive atmospheres.

The pumps are not suitable for transferring:

- Dusts
- Liquids
- Aerosols
- Biological and microbiological substances
- Fuel
- Explosives and flammable materials
- Fibers
- Oxidants
- Foodstuffs.

As standard, the pumps must not be used for simultaneous generation of a vacuum and positive pressure.

This function can be made possible on a project basis following consultation with KNF Customer Service.

Do not apply positive pressure to the inlet of the pump.

This function can be made possible on a project basis following consultation with KNF Customer Service.

2.7. Directives and standards

EU/EC directives

With respect to the Machinery Directive 2006/42/EC, the pumps are partly completed machinery and are, therefore, to be regarded as not ready for use. Partly completed machinery may not be commissioned until it has been determined that the machine into which the partly completed machinery is to be installed complies with the provisions of the Machinery Directive 2006/42/EC. The following fundamental requirements of Annex I of Directive 2006/42/EC (general principles) are applied and observed:

- General principles no. 1
- No. 1.1.2. / 1.1.3. / 1.3.1. / 1.3.3. / 1.3.4. / 1.4.1. / 1.5.8. / 1.5.9. / 1.7.4. / 1.7.4.1. / 1.7.4.3.

Standards

The following standards apply:

- EN IEC 61000-6-2
- EN IEC 61000-6-3
- EN IEC 63000

The protective goals of the following directive(s) are achieved:

- Directive 2011/65/EU on the restriction of the use of certain hazardous substances in electrical and electronic equipment (Annex II changed by delegated Directive (EU) 2015/863 of the Commission)

2.8. Customer service and repair

Customer service and repairs

The pump is maintenance-free. However, KNF recommends periodic inspections to check the pump for obvious changes in noise and vibration.

Only have repairs to the pumps performed by the responsible KNF Customer Service department.

Housings with electrically live components may only be opened by specialized personnel.

Use only genuine spare parts from KNF when performing maintenance work.

2.9. Disposal

Environmental protection

Store the pump and all accessories in accordance with the environmental provisions. Observe national and international regulations. This applies in particular to parts that are contaminated with toxic substances.

If you no longer need your packaging materials (e.g. for return shipment or other transport of the device), dispose of them in an environmentally friendly manner.

Old devices must not be disposed of with household waste. Proper disposal and recycling helps to protect natural resources and the environment. The end user is responsible for disposing of old devices according to national and international regulations. Alternatively, KNF products (old devices) may also be returned to KNF for a fee (see Chapter 11. Returns).

3. Technical data

Pump wetted materials

Assembly	Material ATV	Material KTV	Material KPV
Pump head	Aluminum	Plastic	Plastic
Diaphragm	PTFE	PTFE	EPDM
Valves	FKM	FKM	FKM
O-ring	FKM	FKM	FKM

Tab. 5: Pump wetted materials

Pneumatic parameters

MGP75-21

Parameter	Value KPV	Value KTV	Value ATV
Max. permissible operating pressure [bar rel.]*	0.4	0.4	0.3
Ultimate vacuum [mbar abs.]	140.0	140.0	140.0
Flow rate at atm. pressure [l/min]**	72.0	71.0	71.0

Tab. 6: Pneumatic parameters

*bar rel. relative to 1000 hPa

**Liters in the standard state (based on ISO 8778 and ISO 21360-1/2) (1000 mbar)

Pneumatic parameters

MGP75-22

Parameter	Value KPV	Value KTV
Max. permissible operating pressure [bar rel.]*	0.3	0.3
Ultimate vacuum [mbar abs.]	25.0	25.0
Flow rate at atm. pressure [l/min]**	35.0 ± 10%	34.0 ± 10%

Tab. 7: Pneumatic parameters

*bar rel. relative to 1000 hPa

**Liters in the standard state (based on ISO 8778 and ISO 21360-1/2) (1000 mbar)

Pneumatic connections

Pneumatic connections	Value
Inlet	Thread size G1/8*
Outlet	Thread size G1/8*

Tab. 8: Pneumatic connections

* Acc. to ISO 228

Electrical parameters

MGP75-21

Parameter	Value KPV	Value KTV	Value ATV
Voltage [V]	24	24	24
Max. rated current draw [A]	5.2	5.6	5.1
Power P ₁ [W]	125	135	123
Motor protection class (DIN EN 60529 / IEC 60529)	IP 20	IP 20	IP 20
Pump protection class	IP 20	IP 20	IP 20
Maximum permissible supply voltage fluctuations	± 10%	± 10%	± 10%

Tab. 9: Electrical parameters

Electrical parameters

MGP75-22

Parameter	Value KPV	Value KTV
Voltage [V]	24	24
Max. rated current draw [A]	3.4	3.8
Power P ₁ [W]	82	92
Motor protection class (DIN EN 60529 / IEC 60529)	IP 20	IP 20
Pump protection class	IP 20	IP 20
Maximum permissible supply voltage fluctuations	± 10%	± 10%

Tab. 10: Electrical parameters

Weight

Pump type	Value
MGP75-__ATV-XT	3.2 kg
MGP75-__K_V-XT	2.9 kg

Tab. 11

Other parameters

Parameter	Value
Permissible ambient temperature	+ 5°C to + 50°C
Permissible media temperature	+ 5°C to + 50°C
Dimensions	See Fig. 4 and Fig. 5, Chapter 6.1. Installing the pump.
Highest permissible relative air humidity of the environment	80% for temperatures to 31°C, decreasing linearly to 50% at 40°C (non-condensing).
Maximum installation altitude [m above sea level]	2000*

Tab. 12

**Altitudes >2000M above sea level may require additional cooling. Consult your KNF Customer Service representative*

4. Product description

Design

- 1 Pneumatic pump outlet
- 2 Pneumatic pump inlet
- 3 Motor
- 4 Drive controller

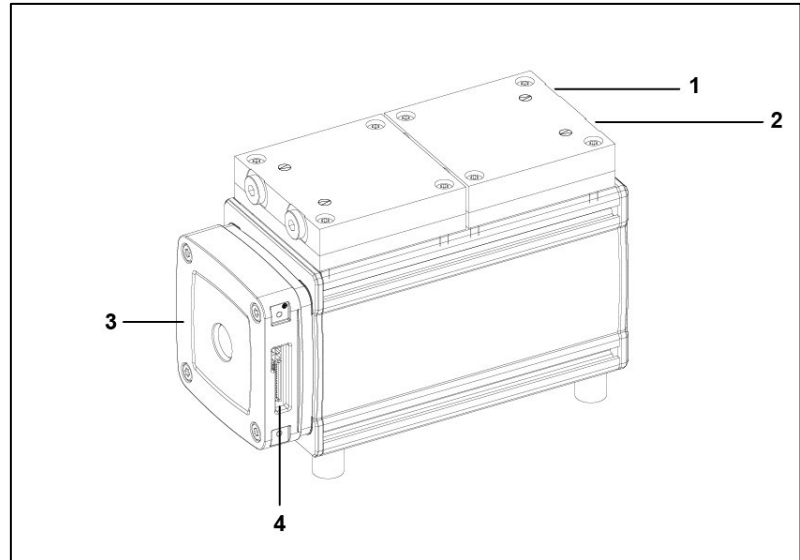

Fig. 1: MGP75-ATV-XT

- 1 Pneumatic pump outlet
- 2 Pneumatic pump inlet
- 3 Motor
- 4 Drive controller

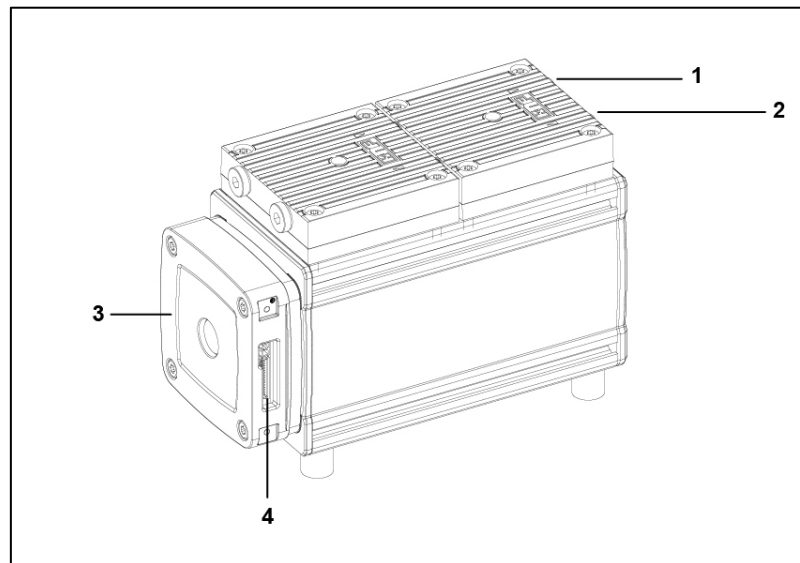

Fig. 2: MGP75-__K_V-XT

Function of a diaphragm pump

- 1 Outlet valve
- 2 Inlet valve
- 3 Pumping chamber
- 4 Diaphragm
- 5 Eccentric
- 6 Connection rod
- 7 Pump drive

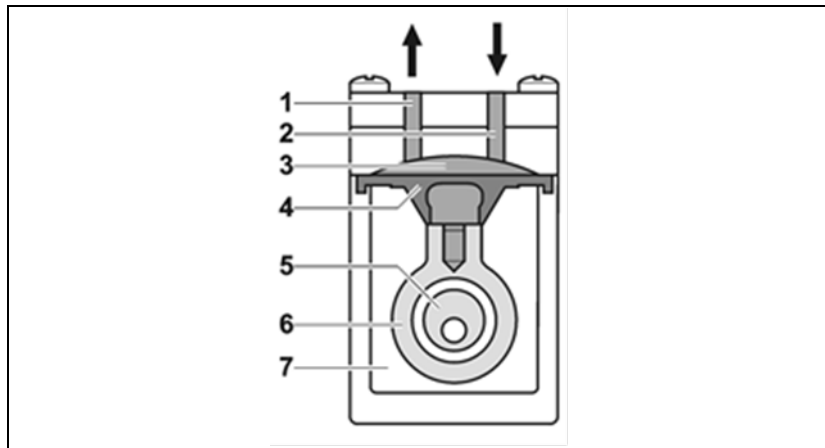

Fig. 3: Pump head

Diaphragm pumps transfer, compress (depending on the version) and evacuate gases and vapors.

The elastic diaphragm (4) is moved up and down by the eccentric (5) and the connection rod (6). In the downwards stroke, it aspirates the gas to be transferred via the inlet valve (2). In the upwards stroke, the diaphragm presses the medium out of the pump head via the outlet valve (1). The pumping chamber (3) is separated from the pump drive (7) by the diaphragm.

5. Transport

5.1. General



CAUTION

Personal injury and/or material damage due to incorrect or improper transport of the pump

In the event of incorrect or improper transport, the pump can fall down, be damaged or injure persons.

- Use suitable auxiliary means if necessary (carrying strap, lifting gear, etc.).
- Where appropriate, wear suitable personal protective equipment (e.g., safety shoes, safety gloves).



CAUTION

Risk of injury from sharp edges on the packaging

There is a risk of injury from cutting on the sharp edges when grabbing corners or when opening the packaging.

- Where appropriate, wear suitable personal protective equipment (e.g., safety shoes, safety gloves).



CAUTION

Personal injury and/or material damage due to incorrect or improper transport of the pump

If the pump is raised and/or carried on the connection during transport, leaks and/or damages to the pump may result.

- Do not carry the pump on the pneumatic connection.

- Transport the pump in the original packaging to the installation location.
- Keep the original packaging of the pump (e.g. for later storage).
- Inspect the pump for transport damage after receiving it.
- Document any transport damage that has occurred.
- Remove any transport safeguards on the pump prior to commissioning.

Parameter

Parameter	Value
Storage temperature [°C]	+ 5 to + 40
Transport temperature [°C]	- 10 to + 60
Permissible humidity (non-condensing) [%]	30 to 85

Tab. 13: Transport parameters and storage parameters

Damage to the pump

Commissioning at an insufficient temperature can lead to malfunctions or damage to the pump.

NOTICE

→ Prior to commissioning, make sure that the pump has reached the ambient temperature (3. Technical data).

6. Installation and connection

Only install the pumps in accordance with the operating parameters and conditions described in Chapter 3. Technical data . Observe safety notices (see Chapter 2. Safety).



DANGER

Risk of dangerous gas mixtures during pump operation

Depending on the pumped medium, rupture of the media-contacting components can result in a dangerous mixture if the medium mixes with the air in the pump housing or the surroundings.

- Before using a medium, check the compatibility of the media-contacting components (see 3. Technical data) with the medium.

6.1. Installing the pump

- Store the pump at the installation location to allow it to adapt to the ambient temperature before installation (condensation must not be allowed to form).

Mounting dimensions

- For mounting dimensions, see Fig. 4 and Fig. 5.

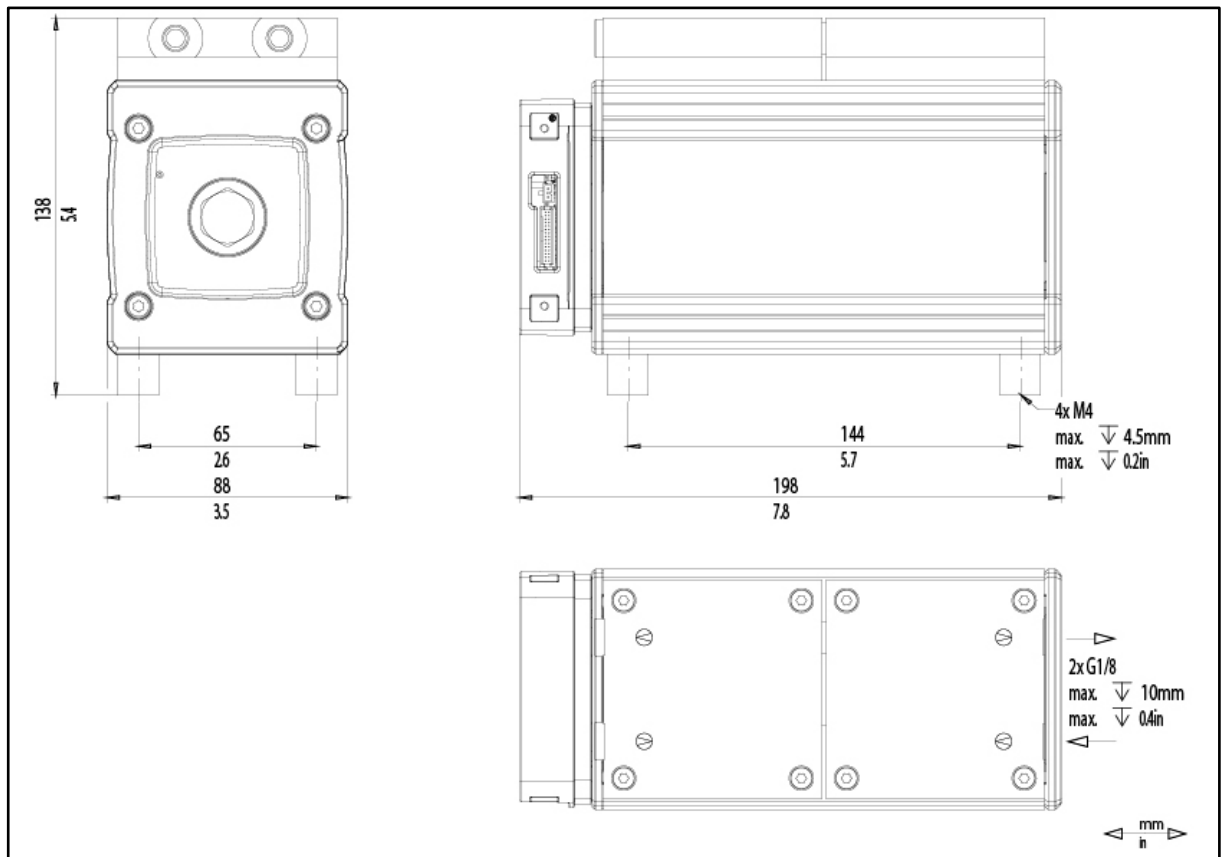

Fig. 4: Mounting dimensions of pump type MGP75-21ATV-XT

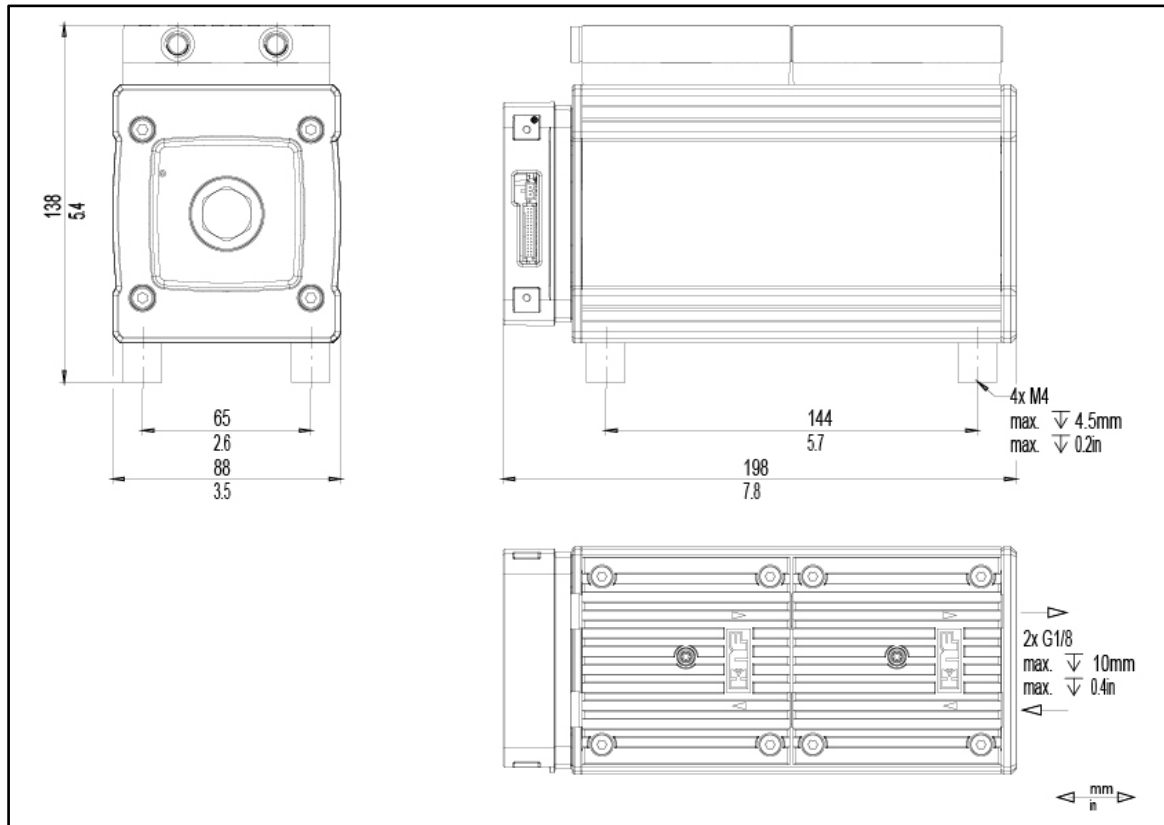

Fig. 5: Mounting dimensions of pump type MGP75-21K_V-XT

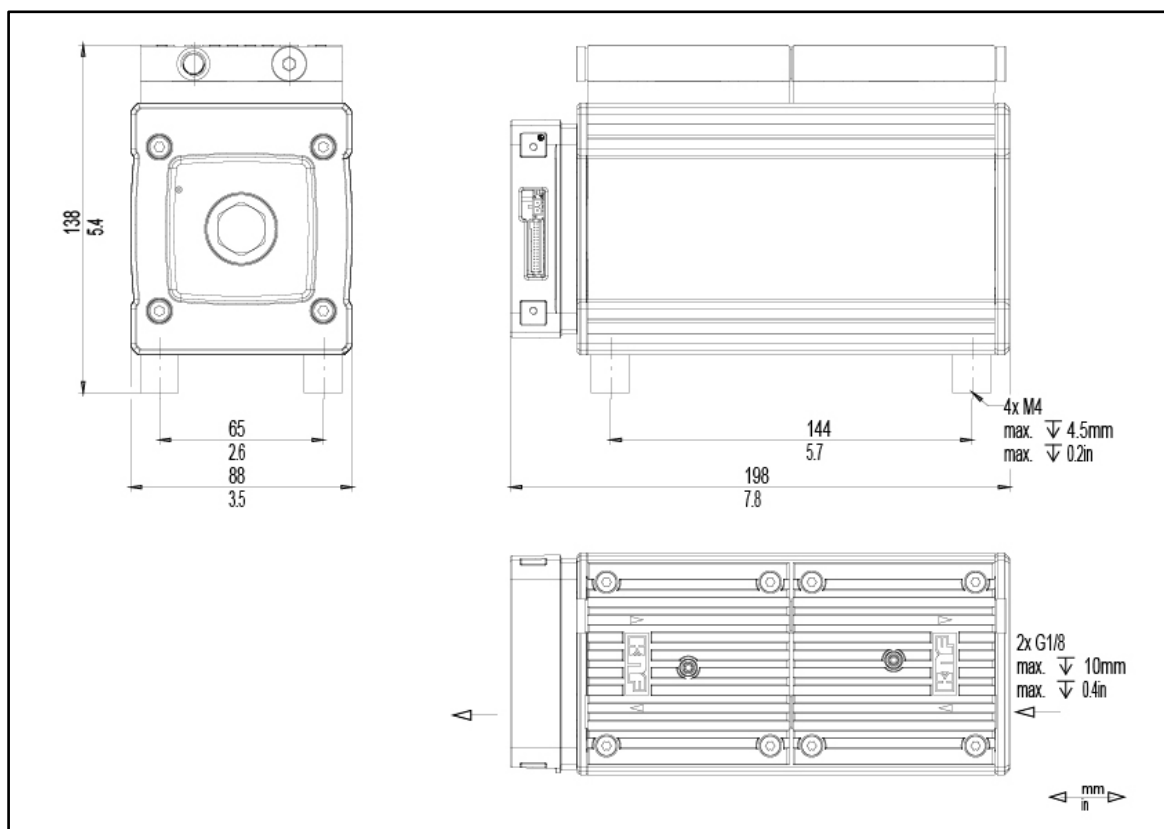

Fig. 6: Mounting dimensions of pump type MGP75-22K_V-XT

Cooling air supply

**WARNING**

Burns from hot surfaces

Hot surfaces could occur if the pump overheats.

→ When installing the pump, ensure sufficient air circulates across the pump.

Proximity to hot pump parts

→ During installation, make sure no combustible or thermally deformable objects are positioned in proximity to hot pump parts (head, motor).

Installation location

→ Make sure that the installation location is dry and that the pump is protected from rain, spray water, splash water, dripping water and other contamination.

→ Make sure the installation location allows access for servicing.

i The IP protection class of the pump motor is specified on the type plate.

→ Install the pump at the highest point in the system to prevent condensate from collecting in the pump head.

→ Protect the pump from dust.

→ Protect the pump from coating with greases and oils.

→ Protect the pump from vibration and impact.

Installation position

→ The pump can be operated in any installation position. Use metal screws to fasten the pump at the indicated attachment points. Observe the specifications of the selected fasteners.

i Use rubber feet (accessories) to reduce vibration and noise. However, overhead or side mounting is then no longer permitted.

**WARNING**

Personal injury and/or material damage from vibrations

Pump vibrations, in combination with adjacent components, can result in crushing and/or damage to these components.

→ Make sure that pump vibrations cannot lead to dangerous interactions with adjacent components.



Risk of injury during operation

Touching electrical, hot or moving parts of the pump during installation can cause injuries.

WARNING

- Take protective measures against touching the electrically live parts (electrical connection, motor windings if applicable).
- Take protective measures to safeguard against touching moving and hot parts.
- Automatic restart after tripping of the self-resetting protection temperature limiter.



Risk of pump damage during operation

During installation and/or subsequent operation of the pump, foreign bodies may enter and damage the pump.

CAUTION

- Take protective measures against allowing foreign objects to enter the pump.

Protection against foreign objects

-
- Take protective measures against touching and foreign objects which could enter the pump.

6.2. Electrical connection



DANGER

Risk of death due to electric shock

Improper electrical connection of the pump can result in electric shocks, which can lead to serious injury or even death.

- ➔ Only have the pump connected by specialized personnel.
- ➔ Only have the pump connected if the power supply is disconnected.

-
- ➔ For electrical connection to a power source, observe the applicable standards, regulations, directives, and technical standards.
 - ➔ The pumps have been developed, manufactured and tested for S1 operation.
Additional operating modes can be made possible on a project-specific basis following consultation with KNF Customer Service.
 - ➔ Install a device for separating the pump motor from the electrical power supply in the electrical installation (e.g., in accordance with EN 60335-1).
 - ➔ KNF recommends operating the motors with a SELV or PELV power supply.
Depending on the customer's device, we recommend connecting the housing to ground.
 - i** Refer to the type plate for the maximum current draw of the pump.
 - ➔ Install an Emergency Off device such that it is not possible for there to be an automatic restart or for hazardous situations to persons and property to occur.
 - ➔ Install the pumps in such a way that it is not possible to touch electrically live parts (electrical connection)
 - ➔ Fasten the connection cables so that
 - the cables do not come into contact with movable or hot parts.
 - the cables cannot be worn or damaged on sharp corners or edges.
 - no tensile and pressure forces are exerted on the connection point of the cables (strain relief).

Fastening the connection cables

Connecting the pump

1. Confirm that the power supply meets the parameters listed on the pump type plate. Refer to the pump type plate for the rated current draw.
2. Connect the positive and negative terminals.

i Ensure the correct polarity:
 Red connection cable: +
 Black connection cable: -

i For connector specifications, see Chapter 12.3. Power supply of the motor and Chapter 12.4. Control signals.

6.3. Pneumatic connection



CAUTION

Personal injury or material damage through ejected plugs

If not removed, the plugs on the pressure side of the pump can be ejected during operation by the resulting overpressure.

→ Remove plugs during installation.

- | | |
|----------------------|--|
| Connected components | → Only connect components to the pump that are designed for the pneumatic data of the pump (see Chapter 3. Technical data). |
| Pump discharge | → Discharge the possibly hot pump discharge at the pneumatic outlet of the pump safely (with regard to medium and noise). |
| Decoupling | → KNF recommends mechanically decoupling the pump from the pipe system, e.g., through the use of flexible hoses or pipes. In this way it is possible to prevent the transfer of possible pump vibrations and noises to the system. |

Connecting the pump

i A marking on the pump head indicates the flow direction.



CAUTION

Risk of injury due to mixing up inlet and outlet

Mixing up the inlet and outlet may cause breakage of components connected at the inlet and outlet.

→ Observe the marking of inlet and outlet on the pump head.

1. Remove the protective plugs from the hose connection threads.
 2. Screw accessories such as silencers or hose nipples (if present) onto the corresponding connections.
- i** The silencer is to be mounted in the outlet of the pump.
3. Connect the suction line and the pressure line (for mounting dimensions, see Chapter 3.).
 4. Lay the suction line and the pressure line at a downward angle to prevent condensate from running into the pump.

7. Operation

7.1. General



Risk of burns from hot pump parts and/or hot medium

WARNING

Some pump parts may be hot during or after operation of the pump.

- Allow the pump to cool after operation.
 - Take protective measures to protect against touching hot parts/media.
-



Injury to eyes

WARNING

Coming too close to the inlet/outlet of the pump may result in injury to the eyes due to the present vacuum/operating pressure.

- Do not look into the inlet/outlet during operation.
-

- Only operate the pumps under the operating parameters and operating conditions as described in Chapter 3. Technical data.
- Ensure the proper use of the pumps (See Chapter 2.6.1. Intended use of instrument).
- Rule out the possibility of foreseeable misuse of the pumps (see Chapter 2.6.2 Improper Use).
- Observe the safety instructions (Chapter 2. Safety).
- The pumps are built-in devices. Before they are commissioned, it must be ensured that the machines or systems into which the pumps are installed comply with the relevant provisions.

**WARNING**

Risk of bursting of pump head due to excessive pressure increase

Excessive pressure increase during pump operation can cause the head to burst, resulting in material damage or personal injury.

- Do not exceed the maximum permissible operating pressure (see 3. Technical data).
- Monitor the pressure during operation.
- If the pressure exceeds the maximum permissible operating pressure of the pump: Switch the pump off immediately and remedy the malfunction (see Chapter 10. Rectifying faults).
- Only throttle or regulate the air or gas quantity on the inlet line to prevent the maximum permissible operating pressure from being exceeded.
- If the air quantity or gas quantity on the outlet line is throttled or regulated, make sure that the maximum permissible operating pressure at the pump is not exceeded.
- Ensure that the pump outlet is not closed or restricted.

**NOTICE**

Material damage due to excess pressure

Exceeding the maximum permissible operating overpressure can result in material damage to the pump.

- Excessive pressure, with all of the associated hazards, can be prevented by means of a bypass line with a pressure relief valve between the outlet and inlet of the pump. Further information is available from KNF Customer Service (contact data: see www.knf.com).

**WARNING**

Risk of dangerous gas mixtures during pump operation if the diaphragm ruptures

If the diaphragm should rupture, the medium will mix with the air in the pump housing or in the surroundings.

- Stop the pump immediately.
 - Replace the diaphragm prior to further operation (see Chapter 8. Maintenance).
-

**NOTICE**

Material damage due to intake of contamination and objects

Operation with open gas connection at the inlet can result in contamination and objects being drawn in.

→ If necessary, take protective measures against the ingress of contamination and objects.

-
- Pump standstill → When the pump is at a standstill, establish normal atmospheric pressure in the lines.
- Vapors as medium Preventing condensate from forming in the pump will extend the service life of the diaphragm. Therefore:
- Perform any work with saturated or near-saturated vapors only with a warm pump.
 - KNF recommends: When pumping corrosive media, flush the pump before switching off (see Chapter 8.2.1. Flushing the pump) to extend the service life of the diaphragm.

7.2. Information on switching the pump on and off

Switching on the pump

- Ensure that there is normal atmospheric pressure in the lines when switching on.

Switching off/decommissioning the pump

- At the end of an evacuation or a process, KNF recommends letting the pump run for several minutes with air as the medium to remove condensate from the pump head (drying of the pump).
- Establish normal atmospheric pressure in the lines (relieve pump pneumatically).

- Recommissioning → Before recommissioning, observe the applicable standards, guidelines, regulations and technical standards at the electrical connection.
- Inspecting the pump → Inspect the pump periodically for external damage or leakage.

8. Maintenance



NOTICE

Maintaining the pump

Material damage to the pumps can result from failure to observe the applicable legal regulations and procedures for the location or intervention by untrained or uninstructed personnel.

- ➔ Maintenance may only be performed according to the legal regulations (e.g. work safety, environmental protection) and provisions.
- ➔ Maintenance may only be performed by specialized personnel or trained and instructed personnel.

8.1. Servicing schedule

Component	Maintenance interval
Pump	<ul style="list-style-type: none"> - Perform periodic inspections for external damage or leakage. - Perform periodic inspections for noticeable changes to noises and vibrations.
Gas connections	<ul style="list-style-type: none"> - Perform periodic inspections for external damage or leakage.
Diaphragms and valves	<ul style="list-style-type: none"> - Replace if the pressure or flow rate of the pump changes for no apparent reason. - At the latest, replace when the performance decreases.
Silencer (accessories)	<ul style="list-style-type: none"> - Replace if contaminated.

Tab. 14

8.2. Cleaning

8.2.1. Flushing the pump

When transferring dangerous and environmentally hazardous media, KNF recommends flushing the pump with air at atmospheric pressure for a few minutes prior to switch-off (if necessary for safety reasons: with an inert gas) to extend the service life of the diaphragm.

- ➔ Discharge the media safely.

8.2.2. Cleaning the pump

- Requirements ➔ Pump disconnected from power supply and voltage-free



CAUTION

Risk of burns from hot pump parts

The pump head or motor may still be hot after operation of the pump.

- ➔ Allow the pump to cool after operation.



Health hazard due to dangerous substances in the pump

WARNING

Depending on the pumped medium, caustic burns or poisoning are possible.

- Wear protective equipment if necessary, e.g. protective gloves, safety glasses.
- Clean the pump with suitable measures.



Material damage due to entry of liquids

When cleaning the pump, liquids may enter the inside of the housing, which can damage the pump.

NOTICE

- During cleaning work, ensure that no fluids enter the interior of the housing.

- Only clean the pump with a dry wiping cloth. When cleaning, use no solvents if possible as these can affect the plastic parts.
- Only use solvents during cleaning if head materials are not corroded (ensure resistance of the material).
- If compressed air is available, blow out the components.

8.3. Replacing diaphragm and valves

Requirements

- Disconnect the motor from the power supply network and ensure that it is voltage-free.
- Allow the pump and the motor to cool.
- Clean the pump and remove any hazardous materials from the pump.
- Remove the hoses/pipes from the pneumatic pump inlet and outlet.

Spare parts/tools

Spare part/tool	Quantity
Spare part set*	1
Felt-tip pen	1
TORX® screwdriver T10	1
TORX® screwdriver T20	1
TORX® screwdriver T30	1
Allen key, 5 mm	1
Open-end wrench, size 18	1

Tab. 15: Spare parts/tools

*Acc. to Chapter 9. Spare parts and accessories



Health hazard due to dangerous substances in the pump

WARNING

Depending on the pumped medium, caustic burns or poisoning are possible.

- ➔ Wear protective equipment if necessary, e.g. protective gloves, safety glasses.
- ➔ Clean the pump with suitable measures.



Risk of burns from hot pump parts

CAUTION

The pump head or motor may still be hot after operation of the pump.

- ➔ Allow the pump to cool after operation.

- 1 Head plate
- 2 Intermediate plate
- 3 Diaphragm
- 4 Valves
- 5 Pan head screw
- 6 Fillister head screw
- 7 Shim

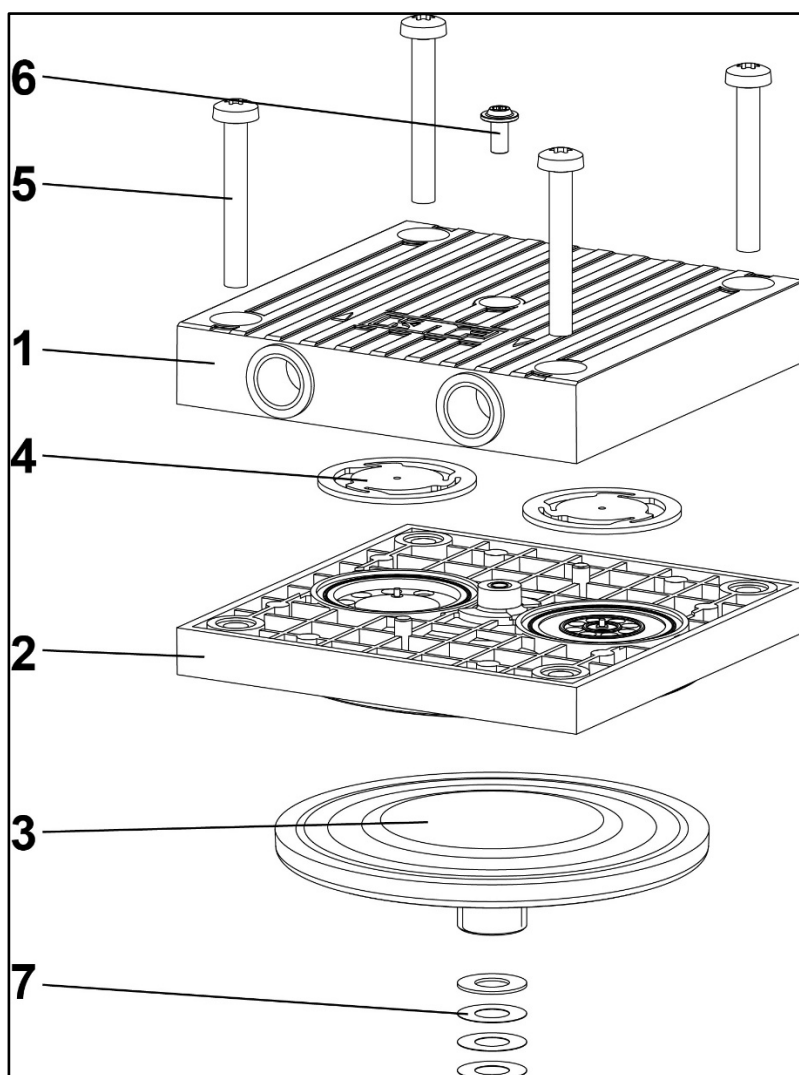

Fig. 7: Pump head (exploded view)

8 Dummy plug

9 M Marking

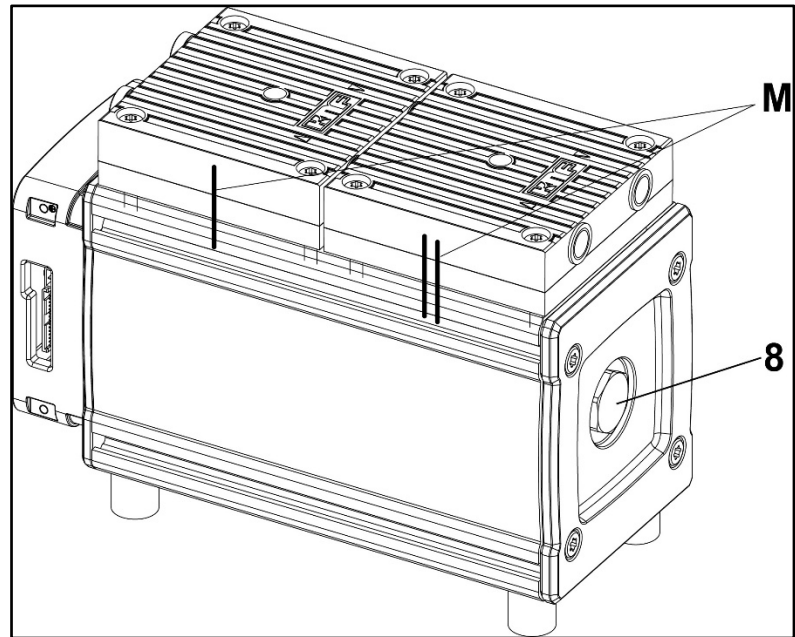

Fig. 8: Pump MGP75__-XT

The diaphragm and valves are to be replaced in the following order:

Initial steps

1. Disconnect the pump from the power supply and ensure that it is voltage-free.
2. Mark the head plate (1), the intermediate plate (2) and the pump housing with a continuous felt-tip pen line. This helps to avoid incorrect assembly later.

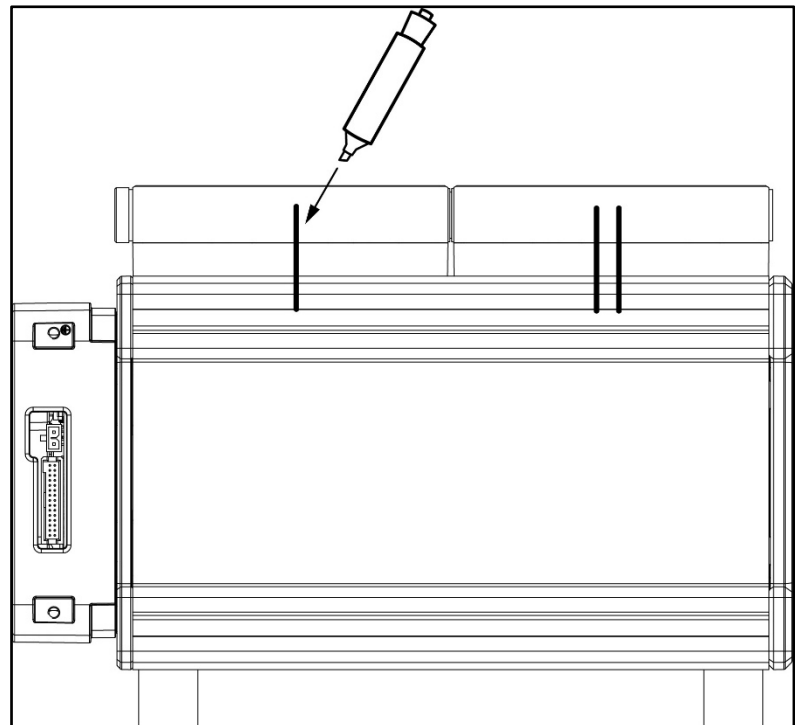

Fig. 9: Marking the pump heads

3. Loosen the head plate screws (4) and the dummy plug (8).

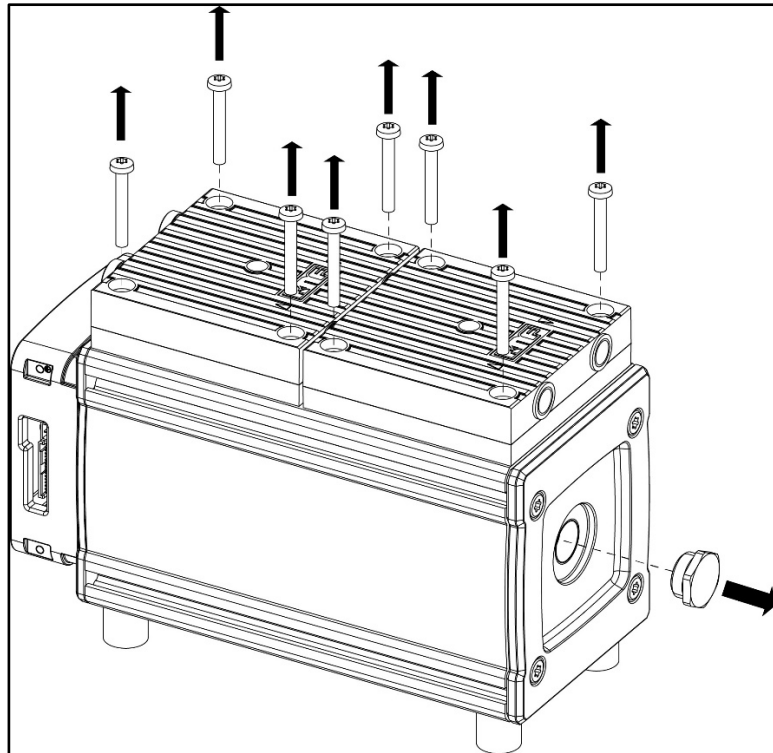

Fig. 10: Loosening the head plate screws and dummy plug

4. Remove the two pump heads (each consisting of head plate (1) and intermediate plate (2)) together from the housing.

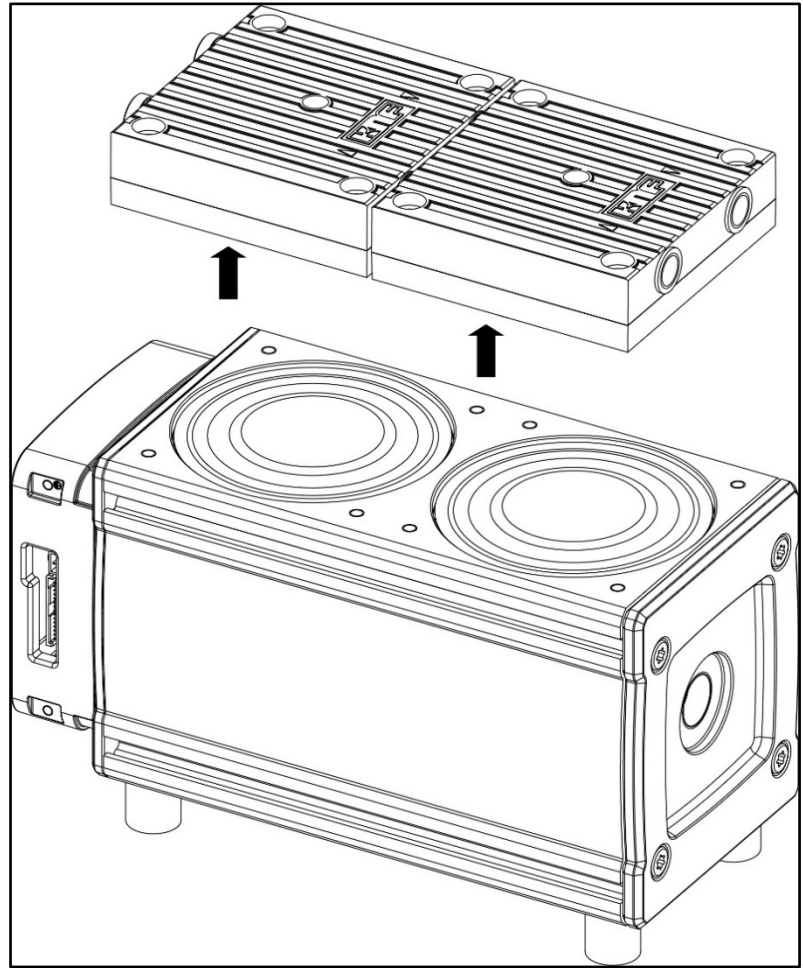

Fig. 11: Removing pump heads

Changing the diaphragm

1. Turn the shaft to move the diaphragm (3) to the upper reversal point.

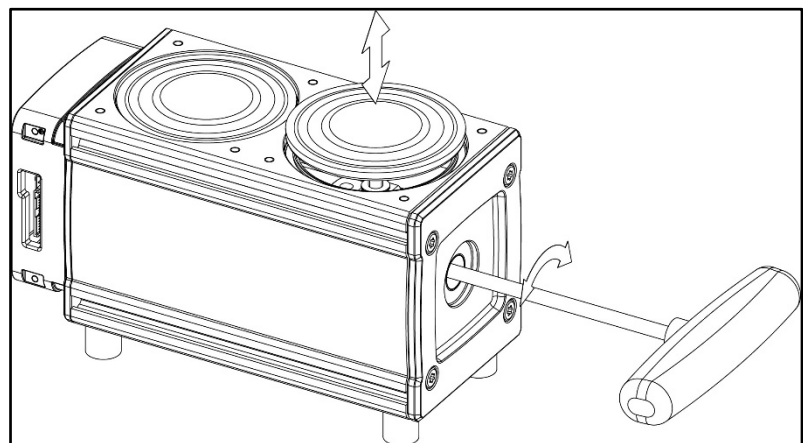

Fig. 12: Diaphragm at upper reversal point

2. Lift the diaphragm (3) on opposing side edges. Then grasp the diaphragm (3) and remove it by turning it counterclockwise.

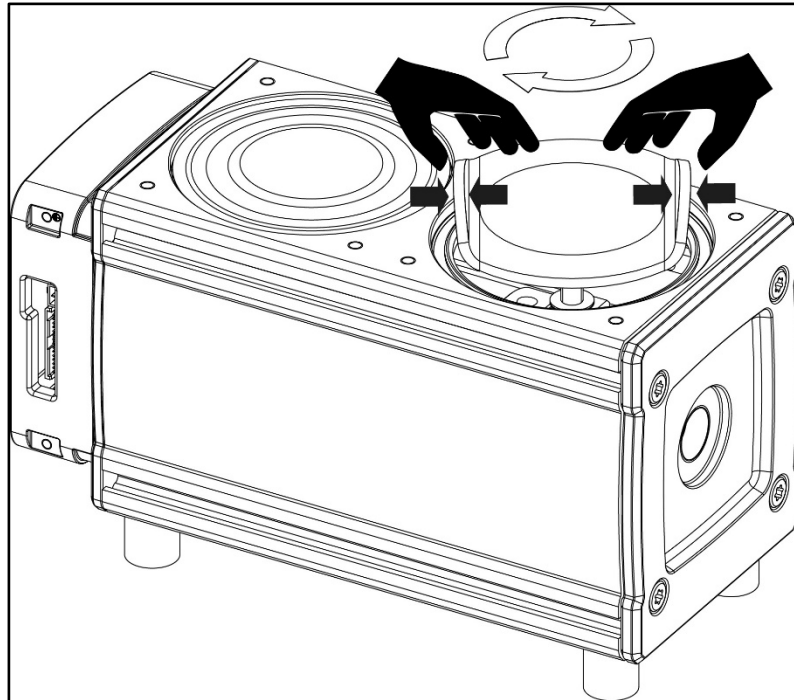

Fig. 13: Lifting and unscrewing the diaphragm

3. Remove the shim(s) (7) from the threaded bolt of the connection rod and keep them in a safe place.
4. Check all parts for contamination and clean them if necessary.
5. Move the connection rod to the upper reversal point by turning the shaft.
6. Place the shim(s) (7) on the threaded pin of the connection rod.
7. Screw the new diaphragm (3) onto the connection rod clockwise and tighten finger-tight.

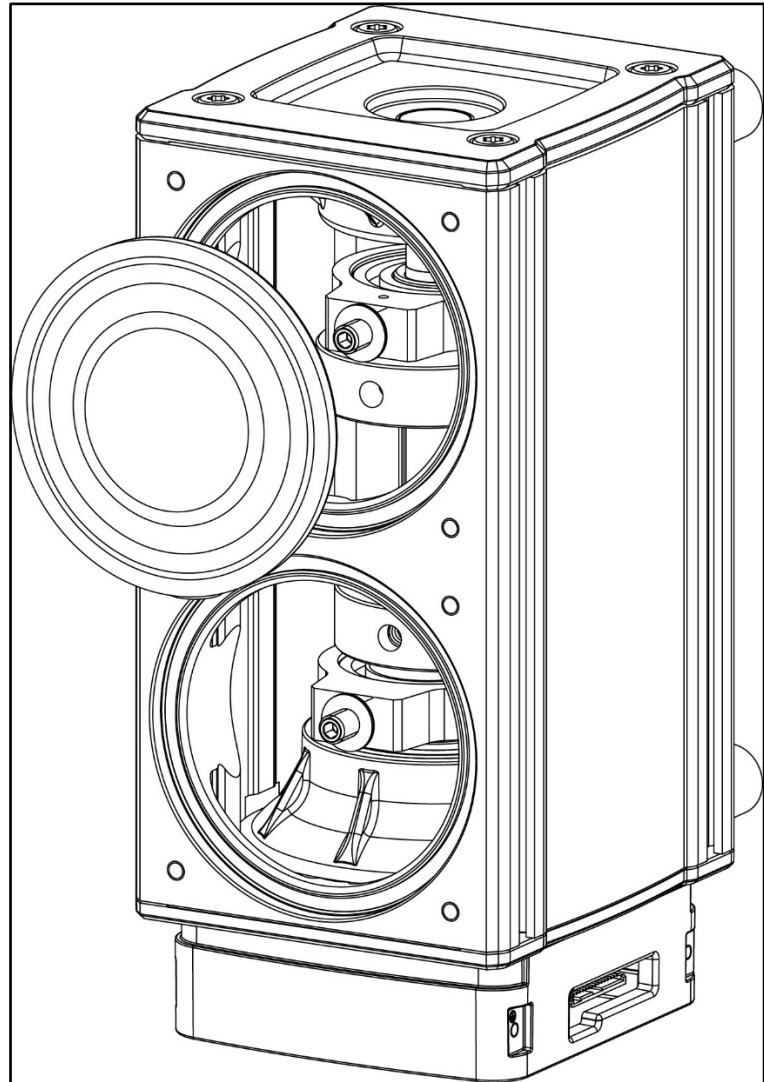

Fig. 14: Screwing the diaphragm in

8. Perform steps 1 to 7 for the second pump head.

Changing O-rings

1. Pull the connection tubes (9) out of one of the two head plates (1).

- 10 9 Connection tube
- 11 10 O-ring
- 12 Screw plug

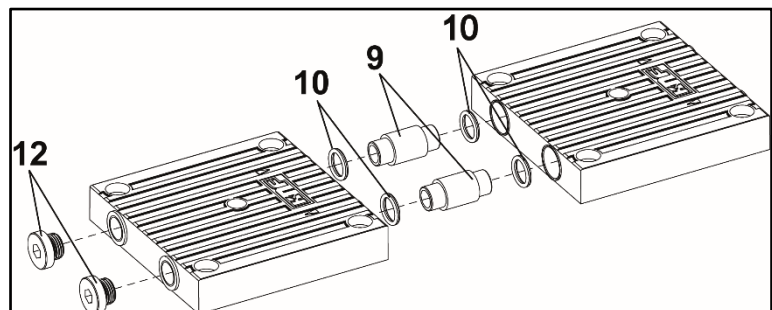

Fig. 15: Removing the connection tubes from the pump head

2. Remove the O-rings (10) from the connection tube (9).
3. Check all parts for contamination and clean them if necessary.
4. Place the new O-rings (10) on the connection tubes (9).

5. Put the connection tubes (9) with the new O-rings (10) back into the two pump heads.
6. Remove the screw plugs (12) and replace them with the new screw plugs (tightening torque: 2.0 Nm).

Changing valves

7. Loosen the screw (6).
8. Separate the head plate (1) from the intermediate plate (2).

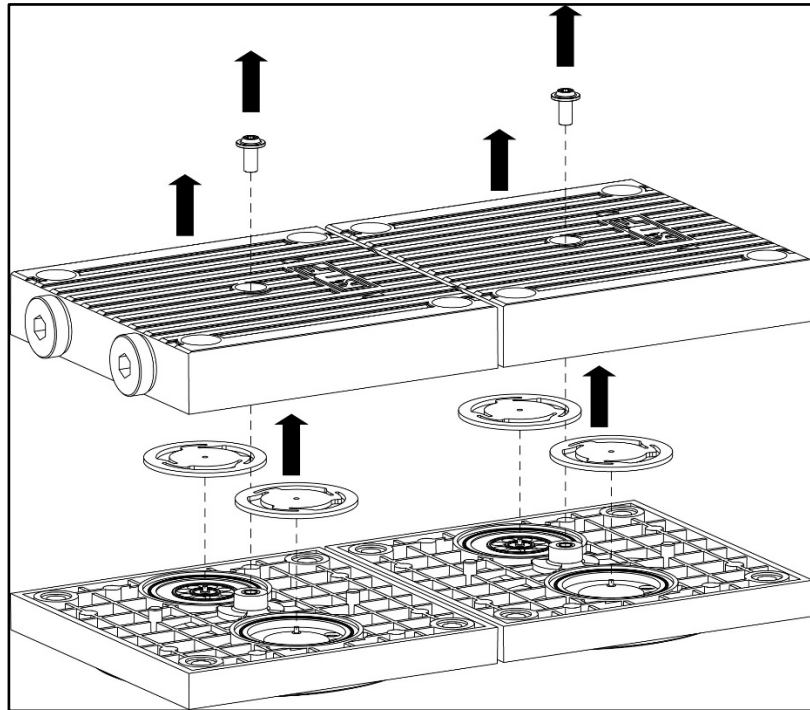

Fig. 16: Separating the head plate and intermediate plate

9. Remove the valves (4) from the intermediate plate (2).
10. Check the valve seats, intermediate plate and head plate for cleanliness; Replace these parts if there are bumps and scratches on them.



NOTICE

Identical valves for pressure and suction side

The valves are identical for the pressure and suction side. The same applies for the top and bottom of the valves.

11. Insert the new valves (4) in the valve seats of the intermediate plate (2).

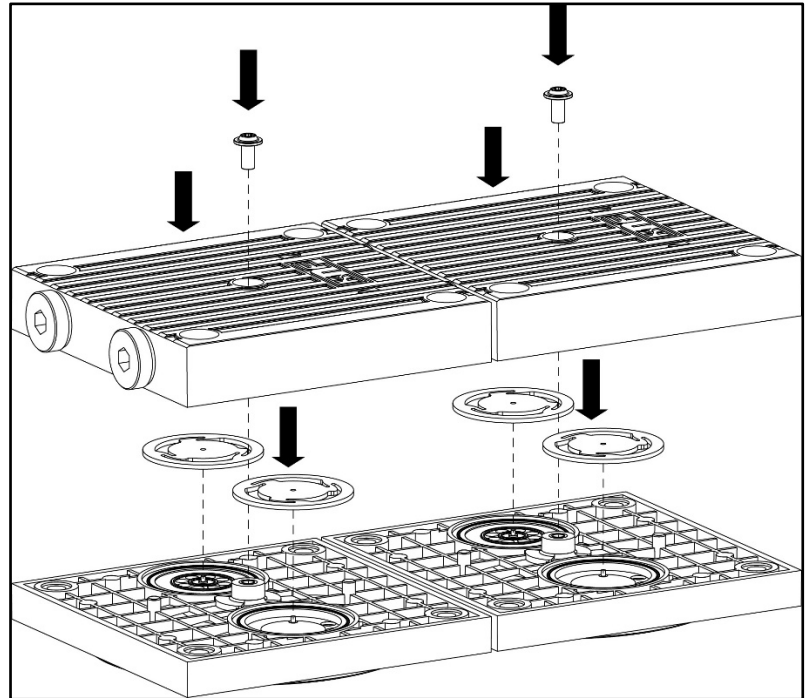

Fig. 17: Placing valves on the intermediate plate

12. By slightly moving the valves horizontally, ensure that they are not under tension.
13. Place the head plate (1) on the intermediate plate (2).
14. Tighten the screw (6) (tightening torque: 60 Ncm)

Mounting the pump head

1. Move the diaphragm to the upper reversal point via the shaft.

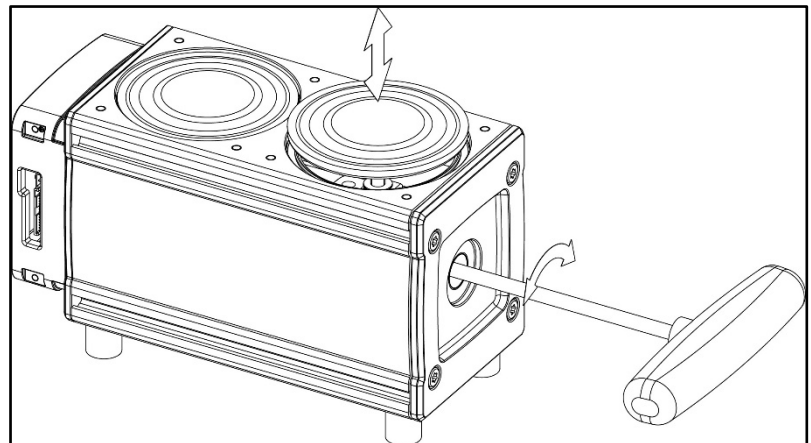

Fig. 18: Turn the shaft and bring the diaphragm to the upper reversal point

2. Place the pump head(s) (consisting of intermediate plate (2) with valves (4) as well as head plate (1)) on the housing according to the markings (M).

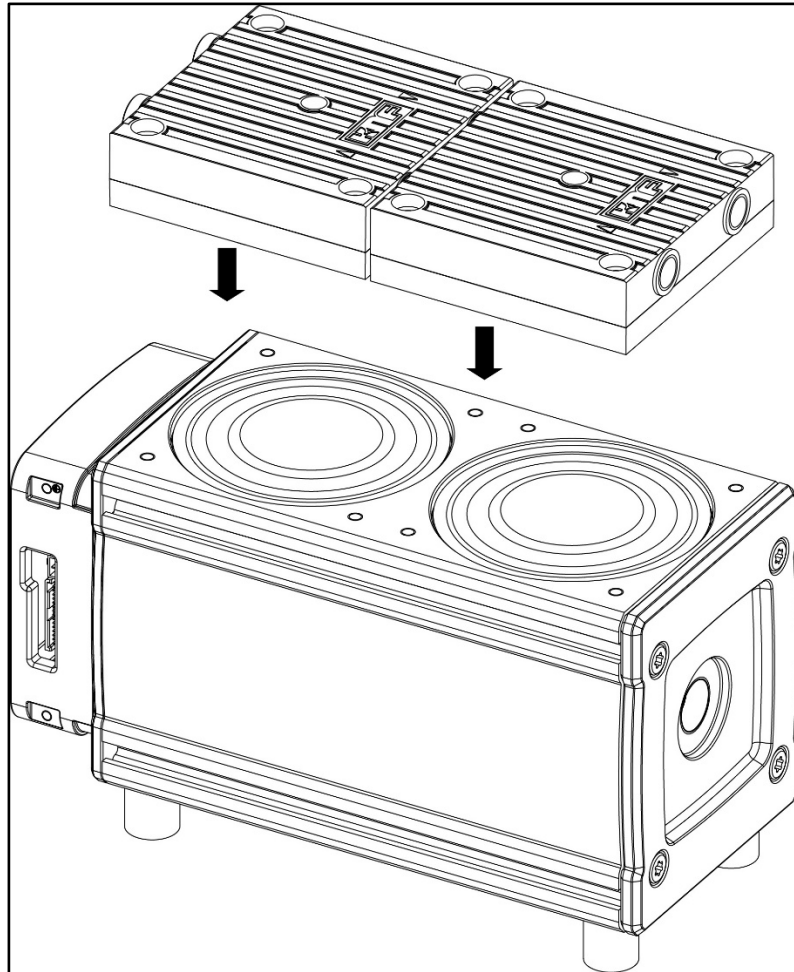

Fig. 19: Attaching the pump heads

3. By moving the head plate (1) slightly horizontally, ensure that the head plate is centered on the centering pin (9) of the intermediate plate (2).
4. Insert the screws (5) into the pump head.

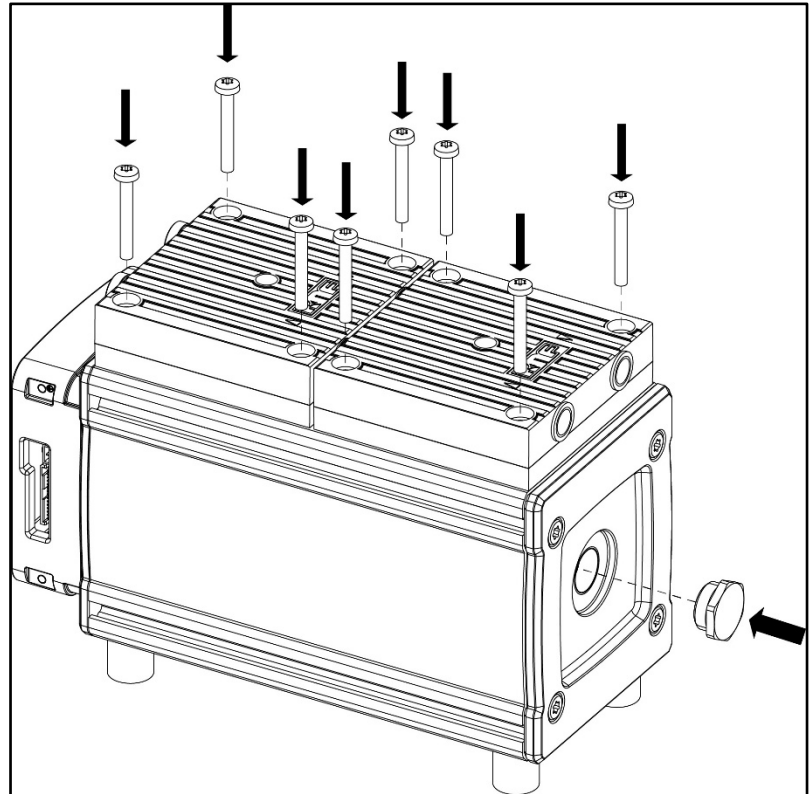

Fig. 20:

5. Only slightly tighten the screws (5) crosswise.
6. Check that the pump runs smoothly by turning the shaft.
7. Tighten the screws (5) finger-tight in a crosswise pattern (tightening torque: 3.4 Nm).
8. Reinsert the dummy plug (8).

9. Spare parts and accessories

i To order spare parts and accessories, please contact your KNF sales partner or KNF Customer Service (contact data: see www.knf.com).

9.1. Spare parts

Spare part set

A spare parts set consists of:

Parts	Item number*	Quantity
Diaphragm	(3)	2
Valves	(4)	4
O-rings	(10)	4
Screw plugs	(12)	2

Tab. 16: Individual parts of a spare parts set

*See chapter 8.3. Replacing diaphragm and valves

Spare part set

Pump type	Order number
MGP75 2_- _PV-XT	353118
MGP75 2_- _TV-XT	353117

Tab. 17: Spare part set

9.2. Accessories

Accessories	Order number
Silencer / intake filter	007006
Adapter NPT1/8 to G1/8	339159
Hose nipple (straight) ID8	004975
Sealing ring	026906

Tab. 18: Accessories

10. Rectifying faults



DANGER

Risk of death due to electric shock

Working on the pump connected to the power supply can result in electric shocks, which can lead to serious injury or even death.

- All work on the pump may only be performed by authorized specialized personnel.
- Before working on the pump: Disconnect the pump from the power supply.
- Check and ensure that no voltage is present.

- Check the pump (see Tab. 19 and Tab. 20).

Pump not delivering	
Cause	Troubleshooting
Pump is not connected to the electrical power supply.	→ Connect the pump to electrical power supply.
No voltage in the electrical power supply.	→ Check the circuit breaker for the room and switch it on if necessary.
Pneumatic connections or lines are blocked.	→ Check the connections and lines. → Remove the blockage.
External valve is closed or filter clogged.	→ Check external valves and filters.
Condensate has collected in the pump head.	→ Separate the source of the condensate from the pump. → Flush the pump with air at atmospheric pressure for a few minutes (if necessary for safety reasons: with an inert gas). → Install the pump at the highest location in the system.
Fault on drive controller.	→ See Chapter 12.5.7.3. Error and warning management
Overcurrent protection of the motor control board tripped Maximum temperature of the motor control board exceeded Maximum stall time of the rotor exceeded	→ Disconnect pump from electrical power supply. → Determine and rectify the cause of the overcurrent, overheating or blocking (e.g., inadmissible pressure conditions, liquid in the pump heads). i The pump must be disconnected from the power supply for several seconds before the electronics reset.
Incorrect polarity of the connection leads	→ Disconnect pump from electrical power supply. → Ensure correct polarity of the connection leads and connect the pump.
Diaphragm and valves are worn or defective.	→ Replace diaphragm and valves (see Chapter 8.3. Replacing diaphragm and valves).

Tab. 19: Troubleshooting: Pump not delivering

Flow rate, pressure or vacuum too low	
The pump does not reach the performance stated in the technical data or data sheet.	
Cause	Troubleshooting
Condensate has collected in the pump head.	<ul style="list-style-type: none"> ➔ Separate the source of the condensate from the pump. ➔ Flush the pump with air at atmospheric pressure for a few minutes (if necessary for safety reasons: with an inert gas). ➔ Install the pump at the highest location in the system.
There is overpressure on the pressure side and at the same time vacuum or pressure above atmospheric pressure on the suction side.	<ul style="list-style-type: none"> ➔ Change the pneumatic conditions.
Pneumatic lines or connection parts have insufficient cross-sections or are constricted.	<ul style="list-style-type: none"> ➔ Disconnect the pump from the system to determine the output values. ➔ Eliminate any constriction (e.g. valve). ➔ Use lines or connection parts with a larger cross-section if necessary.
Leaks occur at pneumatic connections, lines or pump head.	<ul style="list-style-type: none"> ➔ Eliminate the leaks.
Pneumatic connections or lines are partially or completely blocked.	<ul style="list-style-type: none"> ➔ •Check the pneumatic connections and lines. ➔ Remove any parts or particles that are causing blockages.
Head parts are soiled.	<ul style="list-style-type: none"> ➔ Clean the head components.
Working diaphragm broken.	<ul style="list-style-type: none"> ➔ Stop the pump immediately. ➔ Change the diaphragm (see 8.3. Replacing diaphragm and valves).
Diaphragm and valves are worn or defective.	<ul style="list-style-type: none"> ➔ Replace diaphragm and valves (see Chapter 8.3. Replacing diaphragm and valves).
Replaced diaphragm and valves.	<ul style="list-style-type: none"> ➔ Ensure that shims were fitted on the diaphragm thread. ➔ *Check the pneumatic connection and hose connections for leaks.

Tab. 20: Troubleshooting: Flow rate, pressure or vacuum too low

Pump exhibiting changed running noises and vibrations	
Cause	Troubleshooting
Pump bearing worn or defective.	<ul style="list-style-type: none"> ➔ Determine the cause. ➔ Contact KNF Customer Service.

Tab. 21: Troubleshooting: Pump not delivering

Display of the errors at the drive controller

Exceeding the overcurrent limit, exceeding the maximum temperature for the motor control board, or blockage of the rotor are displayed as errors.

The manufacturer only provides for logic 1 or 0 via a voltage at the error output.

To clear the error, the motor must be disconnected from the supply voltage.

Optional setting:

Upon request, the Remote RESET function can be parameterized by KNF.

Fault cannot be rectified

If you are unable to identify any of the specified causes, send the pump to KNF Customer Service (contact data: see www.knf.com).

1. Flush the pump with air for a few minutes (if necessary for safety reasons: with inert gas) at atmospheric pressure to free the pump head of dangerous or aggressive gases (see Chapter 8.2.1. Flushing the pump).
2. Clean the pump (see Chapter 8.2.2. Cleaning the pump).
3. Send the pump together with completed Health and Safety Clearance and Decontamination Form to KNF, specifying the pumped medium.

11. Returns

Preparing for return

1. Flush the pump with air for a few minutes (if necessary for safety reasons: with inert gas) at atmospheric pressure to free the pump head of dangerous or aggressive gases (see Chapter 8.2.1. Flushing the pump).

i Please contact your KNF sales partner if the pump cannot be flushed due to damage.

2. Remove the pump.
3. Clean the pump (see Chapter 8.2.2. Cleaning the pump).
4. Send the pump together with the completed Health and Safety Clearance and Decontamination Form to KNF, stating the nature of the pumped medium.
5. Pack the device securely to prevent further damage to the product. If necessary, request original packaging for a fee.

Returns

KNF shall undertake to repair the pump only under the condition that the customer presents a certificate regarding the medium that is pumped and the cleaning of the pump. In this case too, old devices can be returned. Please follow the instructions at knf.com/repairs here.

Contact your KNF sales partner directly if you require additional support for your return service.

12. Appendix: MO motors

12.1. Terms and designations

BLDC	Brush-Less-DC (motor)
TP	Type inspection
FS	Full Scale
DT	Endurance test
rpm	Revolutions per minute
EV	Ultimate vacuum
HK	Production costs
ED	Maximum pressure
r.F.	Relative humidity
PF	ParameterFile → Text file with various motor parameters
TTL	Transistor-Transistor-Logic

12.2. Limit values

	Value range	Comment
Power supply	24V±10%	
Digital input High	2.0V to 5.2V	TTL (5 V) or LVTTTL (3.3 V) standard signal level related to the GND pins of the motor
Digital input Low	-0.2V to 0.8V	TTL (5 V) or LVTTTL (3.3 V) standard signal level related to the GND pins of the motor
Digital output High	2.4V to 3.3V	LVTTTL (3.3 V) standard signal level related to the GND pins of the motor
Digital output Low	-0.2V to 0.4V	TTL (5 V) or LVTTTL (3.3 V) standard signal level related to the GND pins of the motor
Analog inputs	0 to 5.2V	
5V power supply	5V ± 5%	Suitable for supplying small consumers on the customer side with a current requirement of up to 50 mA.

Tab. 22: Limit values

12.3. Power supply of the motor

The brushless DC motor of the pump is operated with a DC voltage of 24 V. The permissible tolerance of the supply voltage is ±10 %. If the voltage is outside this range, an error is triggered and the motor stops. Error states can be read out and acknowledged via the UART interface – see Chapter 12.5.7.3.



NOTICE

It is recommended to use a power supply unit in accordance with the SELV or PELV standard.



The PE potential should be connected to the motor housing to ensure safe grounding.

NOTICE

12.3.1. Handling the power supply connector

When connecting the power supply connector, you must hear and feel it click into the motor socket. The connector is then securely locked – see Fig. 21.

The connector is protected against reverse polarity and twisting and can only be connected in one defined direction, as shown in Fig. 22.

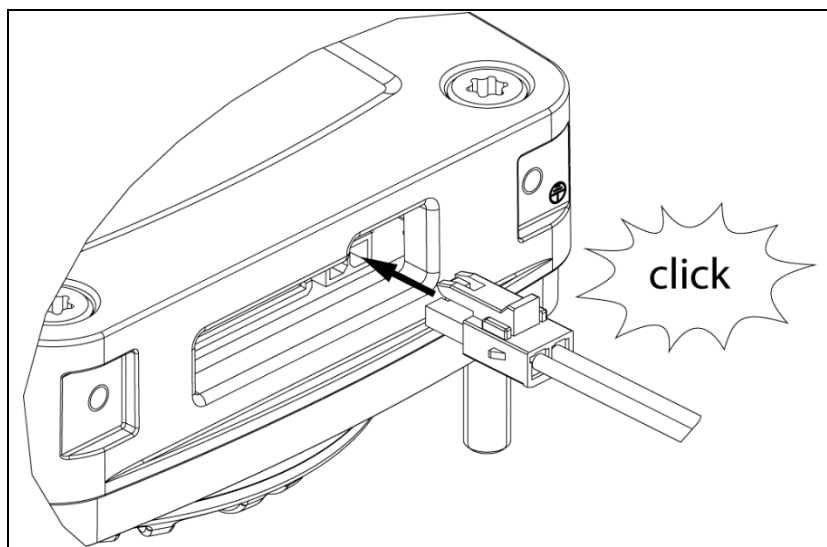

Fig. 21: Inserting the power supply connector

To remove the plug from the motor, first press the connector lock down (see **1** in Fig. 22). The connector can then be pulled out of the motor socket at the same time (**2**).

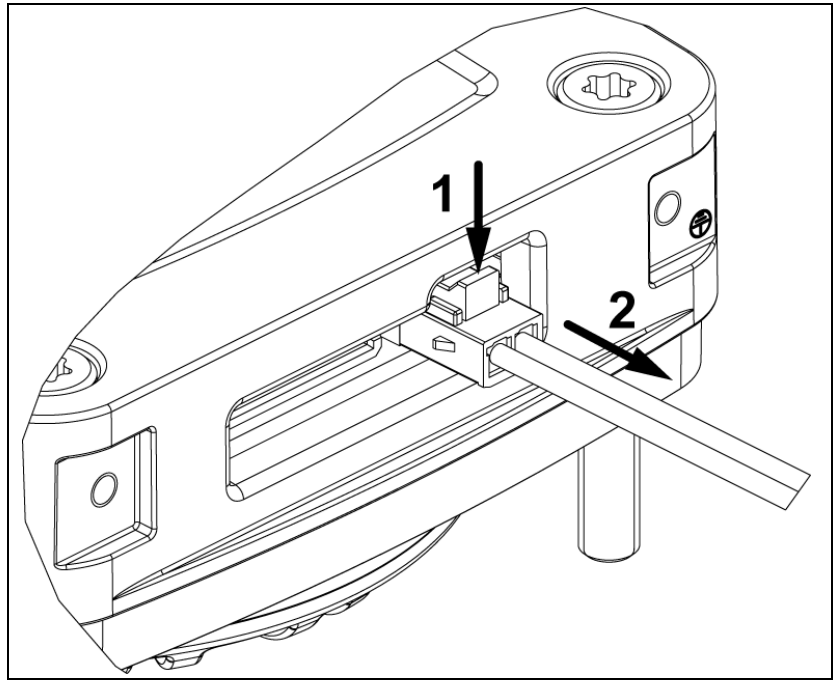

Fig. 22: Removing the power supply connector



Damage to the connector pins or crimping points

If stiff or long cables are used on the motor, the connector pins or crimping points may be damaged.

NOTICE

→ For applications with vibrations, KNF recommends fixing the cables to one of the two threaded holes next to the connectors using a cable fastener.

12.3.2. Pin assignment of the power supply

The following connector is required for the power supply to the motor:

Connector type: Molex 2157591002

Crimp contacts: Molex 2064600041

Cable cross-section: AWG16

The length of the power supply cables is limited to a maximum of 3 m in accordance with the applicable EMC and ESD standards.

Pin no.	Wire lead color	Description
1	Red	24 V ± 10%
2	Black	GND

Tab. 23: Pin assignment of the power supply connector

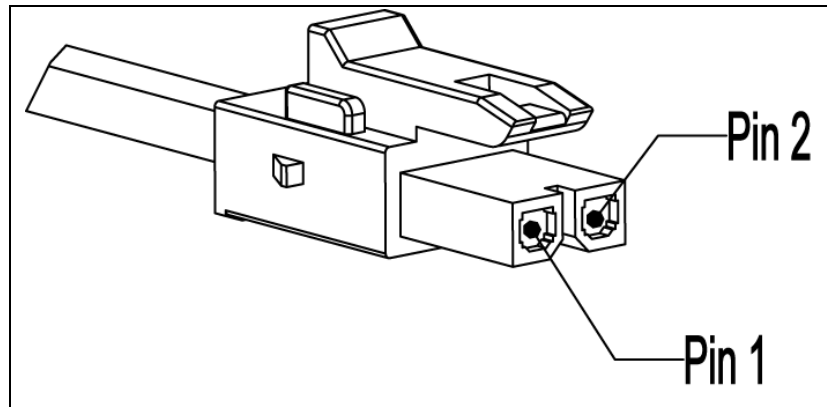

Fig. 23: Pin assignment of the power supply connector

12.4. Control signals

All communication and control signals are housed in a 30-pin connector.

Connector type: Samtec ISDF-15-D-L

Crimp contacts: Samtec CC03M-2830-01-G

12.4.1. Handling the signal connector

The connector system has an anti-twist device that ensures that the connector can only be inserted in one defined position – see the marked corner in Fig. 24. There is also a locking mechanism with haptic feedback. When plugging it in, the connector must be pressed into the socket until a clearly noticeable click is heard. Only then is the connector fully engaged and all contacts are securely connected electrically.

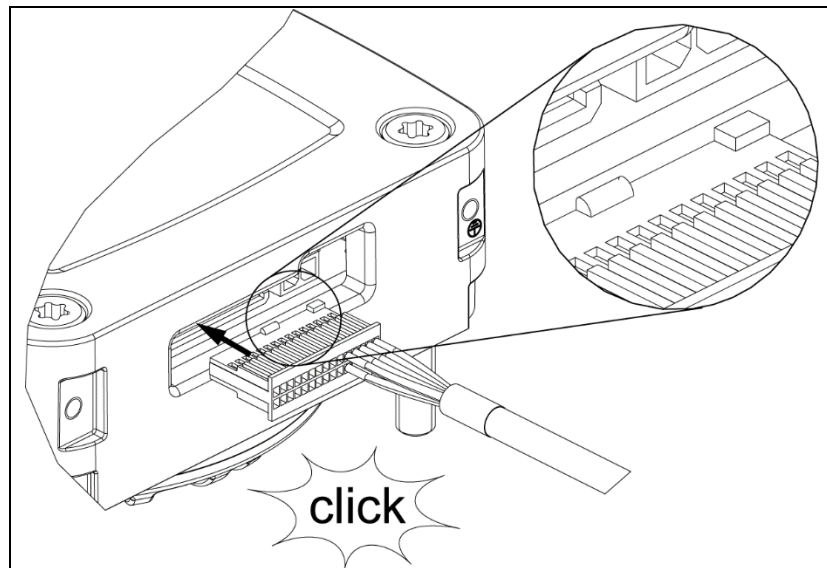

Fig. 24: Engaging the signal connector

To remove the signal connector, it can be carefully pulled out by the connector housing or – with particular care – by the leads – see Fig. 25.

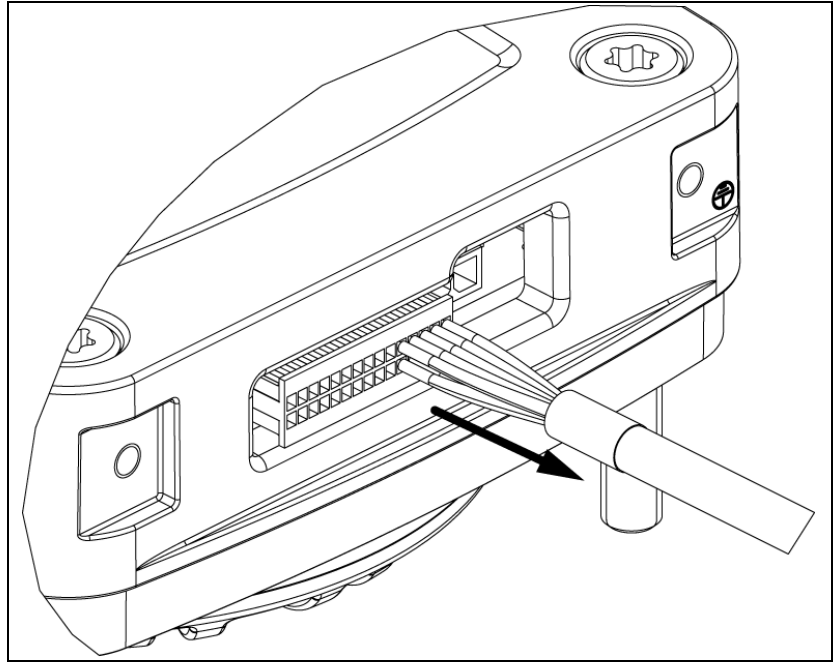

Fig. 25: Disconnecting the signal connector

12.4.2. Pin assignment of the signal connector

In the current expansion stage of the i2 motor, only selected pins of the 30-pin signal connector are active. These are shown in Tab. 24.



NOTICE

All digital inputs and outputs of the motor are LVTTTL-compatible (3.3 V level).

The digital inputs are also TTL-compatible (5 V level).

This means:

The motor supplies LVTTTL signals.

The digital inputs accept both LVTTTL and TTL signals.

Pin no.	Color	Input/output	Designation	Description
21	Red	Digital output	Actual speed output	PWM ¹ Duty cycle 1...99% @ 1 kHz
22	Purple	Digital output	Error signal	Error = high ¹ , No error = low ¹
23	Green	Digital input	ON/OFF	Logical High ¹ = OFF, Low ¹ = ON
24, 27	Brown, black	-	GND ²	0 V
25	Gray	Output Power	5 V ¹	Power supply 5 V (±10%, max. 50 mA)
26	Blue	Input Digital	PWM cycle speed setpoint	LVTTL ¹ 1 ... 99% (100 Hz – 5 kHz)
28	Yellow	Digital output	UART	Tx ³
29	White	Analog input	Analog cycle speed setpoint	0...5 V
30	Orange	Digital input	UART	Rx ³

Tab. 24: Pin assignment of the signal connector

¹ The absolute maximum values are defined in the pump section of the operating and installation instructions.

² All GND pins are connected internally.

³ The definition is made from the pump side.

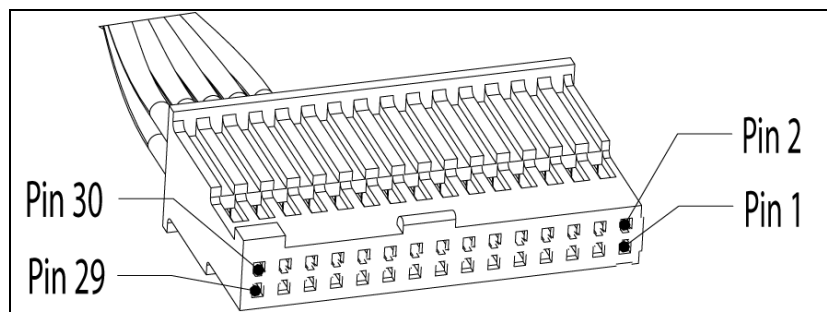

Fig. 26: Signal connector

12.5. Motor signals

12.5.1. Actual speed output

Pin 21

This signal from the motor is available as a PWM signal with a frequency of 1 kHz and provides information about the actual speed of the motor.

If the motor is operating at minimum speed, a PWM signal with a duty cycle of 1 % can be measured at the output; at maximum speed, the duty cycle is 99 %. (The minimum and maximum speed of the motor can be found in the pump data sheet or in the KNF project sheet.) The PWM values are scaled linearly relative to the speed in the entire measuring range. If the motor is at a standstill (0 rpm), the PWM output outputs a logical 0 (PWM = 0 %).

12.5.2. Error signal

Pin 22

The error signal is a digital signal and is set to logical 1 if there is an error. The exact error designation can be read out via the UART interface. The error can also be acknowledged via UART so that the motor starts again.

12.5.3. On/off input

Pin 23

The motor can be started or stopped via this digital input signal:

Logical 1 → Motor stops

Logical 0 → Motor starts

12.5.4. 5 V output

Pin 25

This 5VDC power supply can be used on the customer side to supply small consumers (≤ 50 mA current). Examples of these include: Potentiometer for manual specification of the target speed, UART-RS232 converter, light barriers or buttons for controlling the on/off pin of the motor.

12.5.5. Target speed specification for the motor

There are three options for specifying the desired speed for the motor or pump: Analog signal, PWM signal or via the UART interface.

The input signals are evaluated in the motor with the following priority:

1. UART
2. PWM
3. Analog

If several input signals for speed specification are applied to the motor at the same time, the motor accepts the signal with the highest priority.

Examples:

Analog, PWM and UART signals are available → the motor only takes the value from UART.

Analog and PWM signals are present at the same time → the motor takes the value from PWM.

If only one of the three methods is used to set the speed, the control signal is unambiguous for the motor and it works exclusively with the available signal.



Always connect the GND of the signal source to the GND of the motor to ensure a common reference potential!

NOTICE

12.5.6. Analog target speed specification

Pin 29

The desired pump speed can be set via this analog input using a DC signal. The input can evaluate voltages between 0 V and 5 V.

At 0 V, the motor is set to the minimum speed.

At 5 V to the maximum speed.

Values in between are scaled linearly.



KNF recommends setting a minimum voltage of 0.1 V to minimize unwanted effects caused by noise and interference.

NOTICE



The default setting is 0.1 V to 5 V.



The values for minimum and maximum voltage can be adjusted to customer requirements within this range.

NOTICE

If the applied signal falls below the value for the minimum voltage, the motor can be parameterized so that it either continues to run at minimum speed or stops.



The default setting is: Motor stops.



If the target speed was specified via UART and you then want to switch to analog control (without restarting the drive controller), the command s004;0 must be sent via UART.

NOTICE

12.5.6.1. PWM signal

Pin 26

The PWM signal for target speed specification has priority 2 (see chapter 12.5.5). The digital input can handle signal frequencies from 50 Hz to 5 kHz (customer-side).

The minimum value of the PWM signal is 1 %. At this value, the motor drives the pump at minimum speed.

At a maximum value of 99 %, the motor runs at maximum speed.

Values in between are scaled linearly.

12.5.6.2. UART

Pin 28, 30



To activate the target speed specification via UART, the command s004;1 must first be sent via the UART interface.

NOTICE

The target speed is specified via the UART interface using the command:

s002;xxx

Where xxx stands for the desired speed in rpm.

→ Get the motor ready with command s001;1 before entering the target speed.

Further commands and settings for the UART protocol are explained in the next chapter.

12.5.7. UART communication protocol

UART is the digital interface for communication with the motor. Communication takes place via a protocol specified by KNF.

UART settings

Designation	Setting
Baud rate	115 200 Baud
Data	8
Parity	None
Stop Bit	1
Flow control	None
Termination	CR (carriage return)

Tab. 25: UART settings



A CR must be sent after each command.

NOTICE

i The Rx and Tx specifications in Table 2 are to be understood from the perspective of the pump.

Protocol structure

All motor commands follow the same structure:

The letter "s" for "set" or "g" for "get" is in the first position.

This is followed by a three-digit code that identifies the respective command.

Values can be transferred separated by a semicolon – see Fig. 27.

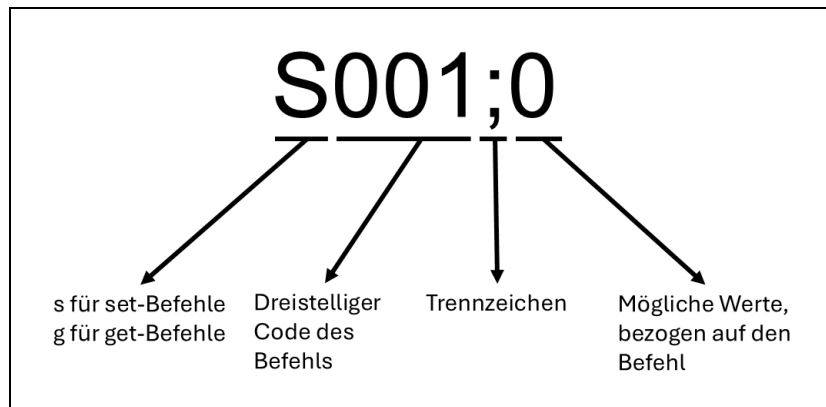

Fig. 27: UART command structure



The protocol receives and sends commands exclusively as ASCII code.

NOTICE

After each command sent, the motor responds either with "OK" if the command is valid, correct and understood, or with an "Exxx" error message.

The error code xxx is explained in chapter 12.5.7.3.

12.5.7.1. Get commands

This group of commands is sent to obtain certain information from the motor or pump.

Get commands	Description
g001	Queries the motor status and has the following possible answers: <ul style="list-style-type: none"> ▪ s000 – Motor is in stand-by ▪ s001 – Motor running
g002	Queries the current actual speed of the motor. The answer is the currently measured actual speed in rpm.
g004	Provides feedback as to whether the digital target specification for the target speed is enabled via UART. The following answers are possible: <ul style="list-style-type: none"> ▪ 0 – UART target specification is disabled ▪ 1 – UART target specification is enabled
g006	Queries whether the motor or pump is currently in "Boost" mode. In the "Boost" state, the motor rotates at a higher speed than the maximum defined speed for a certain period of time. This is followed by a "cool-down time" for the pump. This operating status can only be enabled after consultation with KNF.
g020	Returns the currently measured electrical current in mA that the motor is drawing via the power supply connector.
g021	Returns the currently measured motor temperature in °C.

Get commands	Description
g022	Returns the set value for the acceleration of the rotor in revolutions/s ² when the target speed is changed. This value applies to both starting up and braking the motor.
g023	Returns the value for the direction of rotation of the rotor with the following values: <ul style="list-style-type: none"> ▪ 0 – Clockwise ▪ 1 – Counterclockwise <p>i The direction of rotation influences the performance of the pump and is determined by KNF.</p> <p>i The direction of rotation is defined from the perspective of the shaft side of the motor.</p>
g024	Indicates the operating hours in hours. The specification refers to the time during which the motor has rotated.
g027	Returns the set value for the target speed in rpm.
g028	Returns the set minimum speed of the motor in rpm.
g029	Returns the set maximum speed of the motor in rpm.
g031	Returns the intelligence level of the motor. Possible answers are: <ul style="list-style-type: none"> ▪ -i1, -i2 or -i3
g032	Returns the currently enabled digital interface. Possible answers are: <ul style="list-style-type: none"> ▪ 0 – UART ▪ 12 – I²C ▪ 4 – CAN <p>i UART is defined by default in the standard pump.</p>
g033	Returns the serial number of the pump. This command is only active from intelligence level -i3.
g090	Returns the release date of the current firmware in the motor in the format MMM DD YYYY (example: Sep 15 2025).
g092	Returns the motor designation of the installed motor type – example: MO72.
g093	Returns the name of the parameter file saved in the motor.
g095	Returns a hardware code that is unique. This code enables the installed motor to be uniquely identified.
g096	Returns the number of the firmware version stored in the motor. Example: 01.006.
g099	Returns the project status of the connected pump. The project status can have the following values: <ul style="list-style-type: none"> ▪ 0 – Free project ▪ 1 – Locked project <p>i Locked projects are often used for products with certifications. In this case, every product change is coordinated with the customer or the certification body.</p>

Tab. 26: Get commands

12.5.7.2. Set commands

Set commands	Description
s0001;x	Starts the motor or puts it into standby mode. Possible values for "x" are: <ul style="list-style-type: none"> 0 – Motor stops and remains in standby mode 1 – Motor starts and waits for the target speed
s002;xxx	Sends the desired target speed (xxx) in rpm to the motor.
s003;0	Resets all motor errors.
s004;x	Controls the target speed specification via the UART interface. The position "x" can have the following values: <ul style="list-style-type: none"> 1 – Speed can be specified via UART 0 – Speed can only be specified via PWM or an analog signal
s005;x	Controls the pressure control function integrated in the motor. The value "x" can have the following states: <ul style="list-style-type: none"> 0 – Pressure control is switched off 1 – Pressure control is switched on <p>i The integrated pressure control function is only available from intelligence level -i3 or higher.</p> <hr/> <p> The pressure control function can only be switched on when the motor is at a standstill!</p> <p>NOTICE</p>
s006;x	Controls the "Boost" mode of the pump. When this is activated, the motor rotates at a higher speed, allowing the pump to achieve a higher pneumatic output. Due to the increased heating, this state is time-limited. The switch-on and switch-off times depend on the pump type and the desired speed. This mode is released on a project-specific basis and according to customer requirements. <p>Possible values for "x":</p> <ul style="list-style-type: none"> 0 – Switch mode off 1 – Switch mode on <p>i This mode is not available by default.</p>

Tab. 27: Set commands



12.5.7.3. Error and warning management

Warnings and errors can be read out via the motor protocol in order to monitor the status of the pump and motor. This is done using the following commands:

Error/warning commands	Description
g100	Returns the code (see Chap. 12.5.7.3) for the last error that occurred.
g101	Indicates the last 50 error codes and the operating hours at which they occurred.
g102	Returns the last warning code that occurred. A list of the warning codes can be found in Chap. 12.5.7.3.
g111	Returns the last 50 warnings.

Tab. 28: Error and warning management

The codes for errors and warnings output via UART can be deciphered as follows:

Error Codes	Description
E000	There are no errors. This answer is given after the g100 command.
E001	Motor temperature too high – the motor stops. A temperature warning is issued before the motor stops.
E002	The current via the supply connector is higher than the predefined limit – the motor stops. <div style="display: flex; align-items: center;">  <div style="margin-left: 10px;"> <p>A software function for current protection is integrated in the motor, which simulates a slow-blow fuse. This prevents motor stops and errors during very short current peaks, e.g. when starting.</p> </div> </div> <p>NOTICE</p>
E003	Blocked rotor – the motor stops. Possible causes: Foreign bodies or liquids in the pumping chamber as well as damaged drive components.
E004	Torque overload – the motor stops. Causes can be as with E003 or operation with pressures outside the pump specification.
E005	Supply voltage too high at the supply connector. The voltage must be within the range specified according to Tab. 22.
E006	Supply voltage too low. Set the voltage according to Tab. 22.
E007	Only for intelligence level -i3 or higher: Excessive vibration of the pump.
E008	Error during initialization of the drive controller – the motor cannot start. A restart is required.
E009	The temperature of the power electronics exceeds the predefined limit – the motor stops to protect itself and its components. A temperature warning is issued before stopping.
E400	Communication error via the serial interface, e.g. if a command is entered incorrectly.
E401	Input is outside the valid value range.
E402	Communication error with the drive controller. The motor must be restarted. <div style="display: flex; align-items: center;">  <div style="margin-left: 10px;"> <p>Errors E400, E401 and E402 are not saved in the error ring buffer (command g101).</p> </div> </div> <p>NOTICE</p>

Tab. 29: Interpretation of the error and warning codes output via UART

Warning codes	Description
W000	There are no warnings.
W001	The temperature of the power electronics is only 15 % below the limit temperature.
W002	The current via the supply connector is only 15 % below the defined limit value.
W003	The motor temperature is only 15% below the limit temperature.

Tab. 30: Warning codes

12.5.7.4. Examples of UART communication

1. Motor start at 500 rpm via UART:

```
s004;1 // Activates the speed specification via UART
s001;1 // Starts the motor
s002;500 // Sets the target speed to 500 rpm
```

2. Speed change to 1000 rpm with the motor running:

```
s002;1000 // Changes the target speed to 1000 rpm
```

3. Motor should be stopped:

```
s001;0 // Stops the motor and puts it into standby mode
```

4. Motor target specification should continue to be supplied via PWM signal:

```
s001;0 // Motor remains in standby mode
s004;0 // Deactivates the UART speed specification, PWM or analog signal is used
```

12.6. Accessories

Accessories	Order number
Cooler	
Cooler and fan	

Tab. 31: Accessories

12.7. Appendix

UART protocol

Command	Description	Answer after the command
g001	Motor status	s000 – stand by s001 – run S100 – error
g002	Get motor speed	xxx - Motor speed in rpm
g004	Digital interface on/off	0 – Digital interface is off 1 – Digital interface is on
g006	Boost mode (dependence of factory settings)	0 – Off 1 – On
g020	Measured motor current	xxx – Motor current in mA
g021	Measured motor temperature	xxx – Motor temperature in °C
g022	Rotor acceleration	xxx – Motor acceleration in turns/s ²
g023	Direction of rotation	0 – Clockwise (cw) 1 – Counterclockwise (ccw)
g024	Working hours	xxx - Working hours
g025	Pump vibration	xxx – Vibration in m/s ² (higher -i3 intelligence level)
g027	Target motor speed	xxx – Target motor speed in rpm
g028	Min. motor speed	xxx – Min. motor speed in rpm
g029	Max. motor speed	xxx – Max. motor speed in rpm
g031	Intelligence level	-i1, -i2, -i3, ...
g032	Type serial interface	0 – UART, 12 – I ² C, 4 – CAN
g033	Pump serial number	xxxx
g090	Firmware release date	MM DD YYYY
g092	Motor type	xxxx
g093	Name of parameter file	xxxx
g095	Unique hardware ID	Example: 000F001E-4841570B-20373833
g096	Release firmware	Example: 01.005
g099	Status project	0 – Free 1 – Locked
g100	Get last error	Exxx – type the error in Tab.??
g101	Get error history	Exxx; Exxx; Exxx; ...
g110	Get last warning	Wxxx – Type the warning in Tab.???
g111	Get warning history	Wxxx; Wxxx; Wxxx; ...
s001;0	Motor stop	OK or Exxx
s001.1	Motor run	
s002;xxx	xxx = Motor target speed in rpm	OK or Exxx
s003;0	Clear all errors	OK or Exxx
s004;0	Serial interface on	OK or Exxx
s004;1	Serial interface off	
s005;0	Pressure control off	OK or Exxx (higher -i3 intelligence level)
s005;1	Pressure control on	
s006;0	Boost mode off	OK or Exxx
s006;1	Boost mode on	

Tab. 32: UART protocol

KNF worldwide

You can find our local KNF partners at: www.knf.com