

**OEM**

**N838\_DC-B (MI)**

**TRANSLATION OF ORIGINAL  
OPERATING AND INSTALLATION  
INSTRUCTION  
ENGLISH**

# DIAPHRAGM PUMP

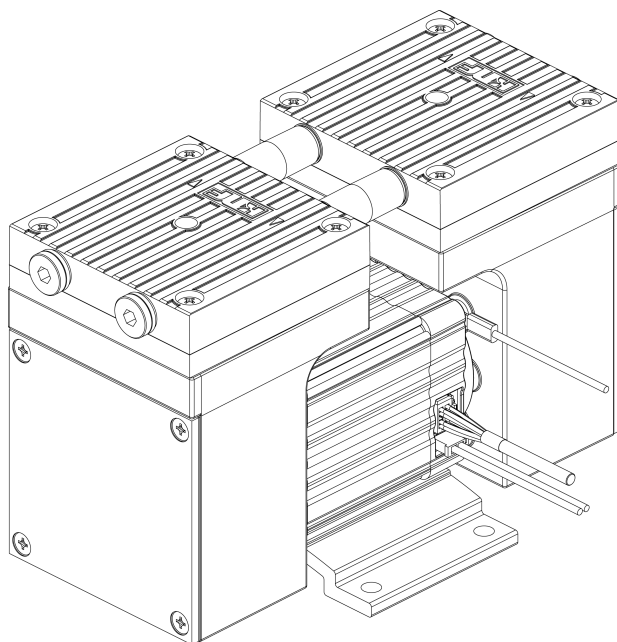

**Notice!**

Before operating the pump and accessories, read and observe the operating and installation instructions as well as the safety information!

# Contents

1	About this document .....	4
1.1	Using the operating and installation instructions.....	4
1.2	Exclusion of liability.....	4
1.3	Symbols and markings.....	5
1.4	List of abbreviations .....	7
2	Safety .....	8
2.1	Personnel and target group .....	8
2.2	Responsibility of the operator .....	9
2.3	Working in a safety conscious manner .....	10
2.4	Operating conditions .....	10
2.5	Media .....	10
2.6	Use.....	12
2.7	Directives and standards .....	13
2.8	Customer service and repair .....	14
2.9	Disposal .....	14
3	Technical data.....	15
3.1	Technical data.....	15
4	Product description .....	20
5	Transport.....	23
6	Installation and connection.....	26
6.1	Installing the pump.....	26
6.2	Electrical connection .....	31
6.3	Pneumatic connection.....	32
7	Operation .....	34
7.1	General .....	34
7.2	Information on switching the pump on and off .....	37
7.3	Speed specification [.29 version] .....	37
8	Servicing .....	39
8.1	Servicing schedule.....	39
8.2	Cleaning.....	40
8.3	Replacing the diaphragm and valve plates .....	41
9	Spare parts and accessories.....	59
9.1	Spare parts .....	59
9.2	Accessories.....	60
10	Troubleshooting .....	61

11 Returns.....	65
12 Appendix MI motors .....	66
12.1 Technical data.....	66
12.2 Supply connector .....	68
12.3 Signal connector .....	69
12.4 Analog control voltage .....	71
12.5 PWM setpoint setting .....	71
12.6 Digital setpoint setting .....	72
12.7 Extended parameterization and functions of the pump [.29 version] .....	76
12.8 Motor accessories .....	78
12.9 Troubleshooting .....	79
13 Appendix: China RoHS .....	80
13.1 KNF Statement on China RoHS.pdf .....	81

# 1 About this document

## 1.1 Using the operating and installation instructions

The operating and installation instructions are part of the pump.

- In the event of uncertainties with regard to the content of the operating and installation instructions, please contact the manufacturer (contact data: see [www.knf.com](http://www.knf.com)). Please have the type and serial number of the pump ready.
- Read the operating and installation instructions before you commission the pump.
- Give the operating and installation instructions only completely and unchanged to the next owner.
- Keep the operating and installation instructions within reach at all times.

**Project pumps** For customer-specific project pumps (pump models that begin with "PJ" or "PM"), there may be deviations from these operating and installation instructions.

- For project pumps, also observe the agreed specifications.

**Optional contents** Project-specific options may be included in the operating and assembly instructions. These are marked with "Optional". It is also possible that project-specific deviations are not included in the operating and assembly instructions.

## 1.2 Exclusion of liability

The manufacturer accepts no liability for damages and failures

- from ignoring the operating and installation instructions.
- due to changes or modifications to the device or improper handling.
- due to the use of impermissible spare parts or accessory parts.

## 1.3 Symbols and markings

### Warning notice



A notice that warns you of danger is located here.

Possible consequences of a failure to observe the warning notice are specified here. The signal word, e.g., Warning, indicates the danger level.

→ Measures for avoiding the danger and its consequences are specified here.

### Danger levels

Signal word	Meaning	Consequences if not observed
DANGER	warns of immediate danger	Death or serious injury or serious damage will result.
WARNING	warns of possible danger	Death, serious injury or serious damage is possible.
CAUTION	warns of a possibly dangerous situation	Minor injury or damage is possible.
NOTICE	Warns of possible damage	Damage is possible.

Tab. 1: Danger levels

## Other notices and symbols









→ An activity to be carried out is specified here (a step).

1. The first step of an activity to be carried out is specified here.

Other sequentially numbered steps follow.

**i** This symbol indicates important information.

## Explanation of pictograms

Pictogram	Meaning
	General warning symbol
	Warning of hot surface
	Warning of electrical voltage
	Warning of poisonous substances
	Warning of hand injuries through crushing
	Observe the operating instructions
	General mandatory sign
	Use hand protection

Tab.2: Explanation of pictograms

## 1.4 List of abbreviations

Abbreviation	Term
PTFE	Polytetrafluoroethylene
FFKM	Perfluoro rubber
PVDF	Polyvinylidene fluoride
PP	Polypropylene
FKM	Fluororubber
FEP	Fluoroethylene propylene
ETFE	Ethylene tetrafluoroethylene copolymer
TFM	Modified PTFE
Tab.	Table
Fig.	Figure
a/o	And/or
e.g.	For example
Perm.	Permissible
et al.	And the like
opt.	If necessary
Max.	Maximum
Min.	Minimum
PWM	Pulse Width Modulation
CW	Clockwise
CCW	Counter-Clockwise
TTL	Transistor-Transistor Logic
DC	Direct Current
GND	Ground
KF	Small flange

## 2 Safety

**i** Observe the warning information in the chapters 6 *Installation and connection* [▶ 26] and 7 *Operation* [▶ 34].

### 2.1 Personnel and target group

**Personnel** Ensure that only specialized personnel carry out work on the pumps. This applies, in particular, to mounting, connection and maintenance work.

Make sure that the personnel have read and understood the operating instructions, particularly the chapter on safety.

**Target group**

<b>Target group</b>	<b>Definition</b>
User personnel	Employee
Specialized personnel	<p>Specialized personnel are personnel who</p> <ul style="list-style-type: none"> <li>- have relevant professional training in the field covered in the particular section of text;</li> <li>- have current knowledge of the field covered in the particular section of text.</li> </ul> <p>A distinction is made between the following specialized personnel:</p> <p>C2: Skilled worker</p> <p>C2-Me: Skilled worker - Mechanical fitter</p> <p>C2-Pi: Skilled worker - Pipeline fitter</p> <p>C2-EL: Skilled worker - Electrician</p>

*Tab.3: Target group*

Who-does-what matrix

Lifecycle phase	User personnel	Specialized personnel
Transport		C2
Mounting		C2-Me
Connection		C2-Pi, C2-EL
Commissioning	X	C2
Operation	X	C2
Maintenance		C2-Me
Troubleshooting		C2C2-Pi, C2-EL
Disposal		C2

Tab.4: Who-does-what matrix

## 2.2 Responsibility of the operator

The pumps are produced in accordance with the generally recognized rules of engineering, as well as the occupational health, safety and accident prevention regulations. Nevertheless, dangers can arise during their use that lead to injuries to the user or third parties or to damage to the pump or other property.

Only use the pumps in perfect technical condition, for their intended use, safely and with an awareness of the dangers and in observation of the operating and installation instructions.

The components that are to be connected to the pumps must be designed according to the pneumatic data of the pumps.

When connecting the pumps to the electrical power supply, observe the corresponding safety rules.

Make sure that no hazardous situation, physical harm or impairment of the pump can occur.

Operating parameters

Only operate and install the pump under the operating parameters and operating conditions described in Chapters 2.4 *Operating conditions* [▶ 10] and 3 *Technical data* [▶ 15].

## 2.3 Working in a safety conscious manner

Observe the regulations on accident prevention and safety during all work on the pumps and during operation.

Avoid contact with the pump heads and housing parts because the pump heats up during operation.

When working on the pump, make sure that the pump is disconnected from the power and free of voltage.

When connecting the pump to the power supply, observe the corresponding safety rules.

Ensure that no hazards arise from gas flowing when gas connections are open, from the effects of noise or from hot, corrosive, dangerous and environmentally hazardous gases.

Ensure that the pump installation is EMC compliant such that no hazardous situations can occur.

## 2.4 Operating conditions

Only use the pump in perfect technical condition, for its intended purpose, safely and with an awareness of the dangers and in observation of the operating instructions.

Only install and operate the pumps in accordance with the operating parameters and conditions described in Chapter 3 *Technical data* [▶ 15].

Only pumps that are fully assembled and in the condition as delivered may be operated.

Make sure that the installation location is dry and that the pump is protected from rain, splash water, gushing water, dripping water and other contamination.

Check the tightness of the connections between the pipes of the application and the pump (or the connection of the pump) at regular intervals. Leaky connections carry the risk of releasing dangerous gases and vapors from the pump system.

## 2.5 Media

Requirements of pumped media Before transferring a medium, check whether the medium can be transferred without risk in the specific application.

Take note of any change in the state of matter (condensation, crystallization).

Before using a medium, check the compatibility of the media-contacting components (see 3 *Technical data* [▶ 15]) with the medium.

Risk of dangerous gas mixtures during pump operation if diaphragm breaks: Depending on the medium being transferred, breakage of the diaphragm can result in a dangerous mixture if the medium mixes with the air in the compressor housing or the surroundings.

Only transfer gases that remain stable under the pressures and temperatures that arise in the pump.

Handling of hazardous media Upon breakage of the diaphragm and/or leaks, the transferred medium mixes with the air in the surroundings and/or in the pump housing.

Make sure that a dangerous situation cannot arise as a result.

When pumping hazardous media, observe the safety regulations for the handling of said media.

Handling of combustible media Note that the pump is not designed to be explosion-proof.

Make certain that the temperature of the medium is always sufficiently below the ignition temperature of the medium so as to prevent ignition or explosion. This also applies for abnormal operating situations.

Note that the temperature of the medium increases when the pump compresses the medium.

Therefore, make certain that the temperature of the medium also remains sufficiently below the ignition temperature of the medium even when it is compressed to the maximum permissible operating pressure of the pump. The maximum permissible operating pressure of the pump is stated in Chapter 3 *Technical data* [▶ 15].

Make certain that the permissible ambient temperature (see 3 *Technical data* [▶ 15]) is not exceeded.

Where applicable, also take into account external energy sources (such as radiated heat sources) that could additionally heat the medium.

In case of doubt, contact KNF Customer Service.

## 2.6 Use

### 2.6.1 Proper use

The pumps are intended exclusively for transferring gases and vapors.

The pumps are intended exclusively for operation in indoor areas and in non-explosive atmospheres.

### 2.6.2 Foreseeable misuse

The pumps must not be operated in explosive atmospheres.

The pumps are not suitable for transferring the following:

- Dusts
- Liquids
- Aerosols
- Biological and microbiological substances
- Fuels
- Explosives and flammable materials
- Fibers
- Oxidizing agents
- Foodstuffs.

As standard, the pumps must not be used for simultaneous generation of a vacuum and positive pressure.

This function can be made possible on a project basis following consultation with KNF Customer Service.

Do not apply positive pressure to the inlet of the pump.

This function can be made possible on a project basis following consultation with KNF Customer Service.

## 2.7 Directives and standards

### EU/EC Directives **Declaration of incorporation – for partly completed machinery**

With respect to the Machinery Directive 2006/42/EC, the pumps are partly completed machinery and are, therefore, to be regarded as not ready for use. Partly completed machinery may not be commissioned until it has been determined that the machine into which the partly completed machinery is to be installed complies with the provisions of the Machinery Directive 2006/42/EC. The following fundamental requirements of Annex I of Directive 2006/42/EC (general principles) are applied and observed:

- General principles no. 1
- No. 1.1.2. / 1.1.3. / 1.3.1. / 1.3.3. / 1.3.4. / 1.4.1. / 1.5.8. / 1.5.9. / 1.7.4. / 1.7.4.1. / 1.7.4.3.

Standards The following standards apply:

- EN IEC 61000-6-2
- EN IEC 61000-6-3
- EN IEC 63000

The protective goals of the following directive(s) are achieved:

- Directive 2011/65/EU on the restriction of the use of certain hazardous substances in electrical and electronic equipment (Annex II changed by delegated Directive (EU) 2015/863 of the Commission)

China RoHS Relevant information has been provided to comply with the regulations of SJ/T 11364-2024 ("Labeling to Control Pollution Caused by Electronic Information Products") and China's administrative methods for controlling pollution caused by electronic information products.

For detailed information, see chapter 13 *Appendix: China RoHS* [▶ 80].

## 2.8 Customer service and repair

Customer service and repairs The pump is maintenance-free. However, KNF recommends periodic inspection of the pump for obvious changes in noise or vibration.

Only have repairs to the pumps performed by qualified KNF personnel.

Housings with electrically live components may only be opened by specialist personnel.

Use only genuine spare parts from KNF when performing servicing work.

## 2.9 Disposal

Environmental protection Store the pump and all accessories in accordance with the environmental provisions. Observe national and international regulations. This applies in particular to parts that are contaminated with toxic substances.

If you no longer need your packaging materials (e.g. for return shipment or other transport of the device), dispose of them in an environmentally friendly manner.

Old devices must not be disposed of with household waste. Proper disposal and recycling helps to protect natural resources and the environment. The end user is responsible for disposing of old devices according to national and international regulations. Alternatively, KNF products (old devices) may also be returned to KNF for a fee (see chapter 11 *Returns* [▶ 65]).

## 3 Technical data

### 3.1 Technical data

#### Pump wetted materials

Pump type	Pump head	Diaphragm	Valves
N838KN_	PPS	EPDM	FPM

Tab.5: Pump wetted materials

#### Pneumatic parameters

Parameter [Unit]	N838KNDC-B N838KN.29DC-B	N838.1.2KNDC-B N838.1.2KN.29DC- B
Max. permissible operating pressure		
[bar rel.*]	0.5	0.5
[psig]	7.3	7.3
Ultimate vacuum at rated speed		
[mbar abs.]	100	100
[inHg]	26.9	26.9
Flow rate at atm. pressure and rated speed		
[l/min]**	34	60
Flow rate at atm. pressure and minimum speed (only .29 versions)		
[l/min]**	8.5	12

Tab.6: Pneumatic parameters

\*bar rel relative to 1000 hPa

\*\*Liters in the standard state (based on ISO 8778 and ISO 21360-1/2) (1000 hPa, 20°C)

#### Pneumatic connections

Parameter	Value
Inlet	Thread size G 1/8
Outlet	Thread size G 1/8

Tab.7: Pneumatic connections

**Electrical parameters**

N838DC-B

Parameter	Value
Voltage [V]	24
Max. rated current draw [A]	2.3
Start-up current	The start-up current can be up to 50% higher than the max. rated current draw.
Max. power consumption of the pump [W]:	55
Maximum permissible supply voltage fluctuations	± 10%
Motor protection class (DIN EN 60529 / IEC 60529)	IP20
Overvoltage category	I

*Tab.8: Electrical parameters***Other motor values**

Parameter	Value
Minimum signal voltage [V]	-0.3
Maximum signal voltage [V]	5.2
Maximum output current per signal [mA]	5
Input impedance [kΩ]	5
Logical 1 level [V]	2.9...5
Logical 0 level [V]	0...0.4
Max. cable length [m]	≤ 3

*Tab.9: Maximum electrical values*



### Damage to the motor electronics

Failure to observe the maximum electrical values may result in damage to the electronics of the motor.

- Observe the maximum electrical values of the motor (see chapter 12.1 *Technical data* [▶ 66]).

#### N838.1.2DC-B

Parameter	Value
Voltage [V]	24
Max. rated current draw [A]	4.2
Start-up current	The start-up current can be up to 50% higher than the max. rated current draw.
Max. power consumption of pump [W]	101
Maximum permissible supply voltage fluctuations	± 10%
Motor protection class (DIN EN 60529 / IEC 60529)	IP20
Overvoltage category	I

Tab. 10: *Electrical parameters*

#### Other motor values

Parameter	Value
Minimum signal voltage [V]	-0.3
Maximum signal voltage [V]	5.2
Maximum output current per signal [mA]	5
Input impedance [kΩ]	5
Logical 1 level [V]	2.9...5
Logical 0 level [V]	0...0.4
Max. cable length [m]	≤ 3

Tab. 11: *Maximum electrical values*



**Damage to the motor electronics**

Failure to observe the maximum electrical values may result in damage to the electronics of the motor.

- Observe the maximum electrical values of the motor (see chapter 12.1 *Technical data* [▶ 66]).



**Protection against overheating**

The pump is protected against overheating by a temperature sensor on the motor control board and is equipped with overcurrent protection. If one of these safety functions is triggered or if the maximum stall time of the rotor is exceeded in the event of a fault, the pump is switched off and must be reset manually:

- Disconnect the pump from electrical mains.
- Before switching back on, eliminate the fault cause(s).

**Weight**

Pump type	Value
N838KNDC-B / N838KN.29DC-B	1.9 kg

*Tab. 12: Weight*

**Other parameters**

<b>Parameter</b>	<b>Value</b>
Permissible ambient temperature	+ 5°C to + 40°C
Permissible media temperature	+ 5°C to + 40°C
Dimensions	See Chapter 6.1 <i>Installing the pump</i> [▶ 26].
Highest permissible relative air humidity of the environment	80% for temperatures up to 31°C, decreasing linearly to 50% at 40°C.
Maximum installation altitude [m above sea level]	2000

*Tab. 13: Other parameters*

## 4 Product description

### Design

- 1 Outlet (pressure side)
- 2 Inlet (suction side)
- 3 Drive controller
- 4 Motor

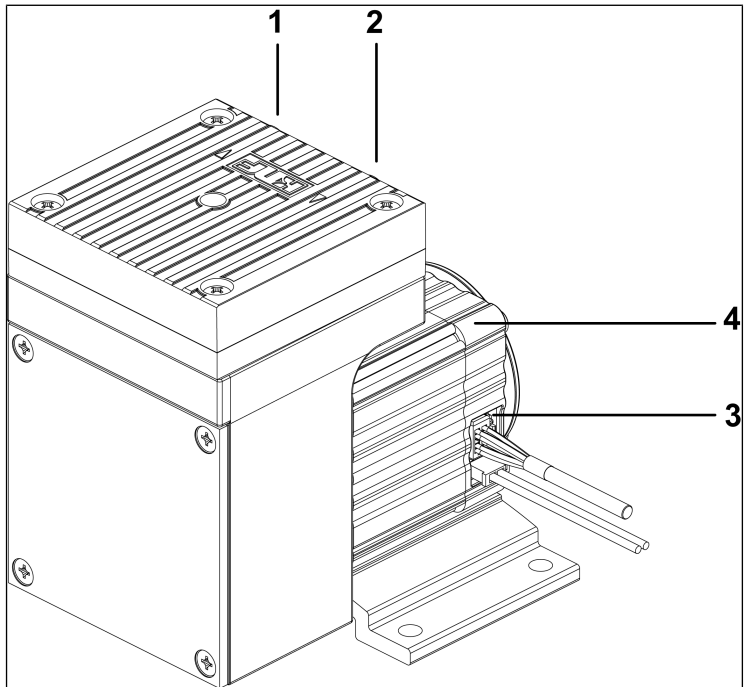

Fig.1: Design N838\_DC-B (MI)

- 1 Outlet (pressure side)
- 2 Inlet (suction side)
- 3 Motor
- 4 Drive controller
- 5 Pneumatic connection

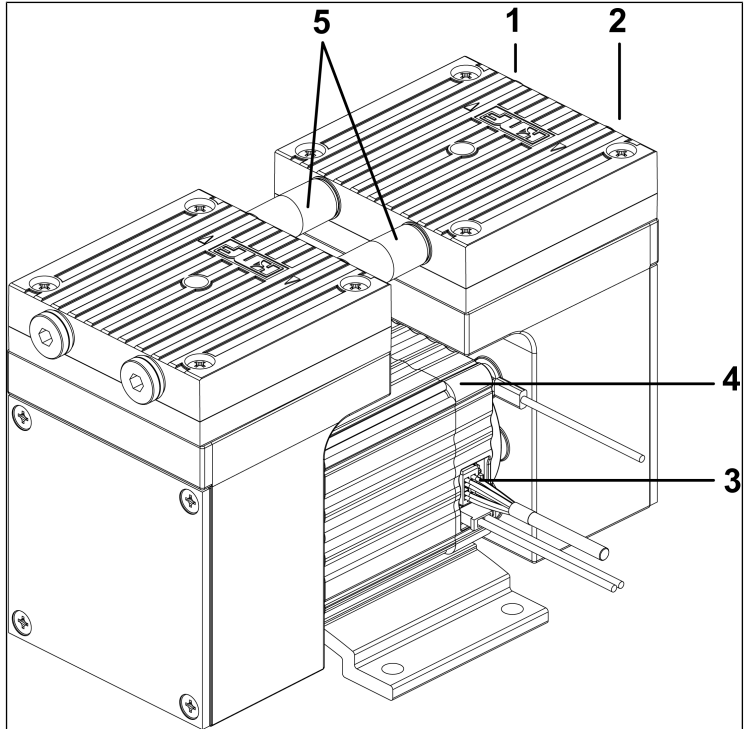
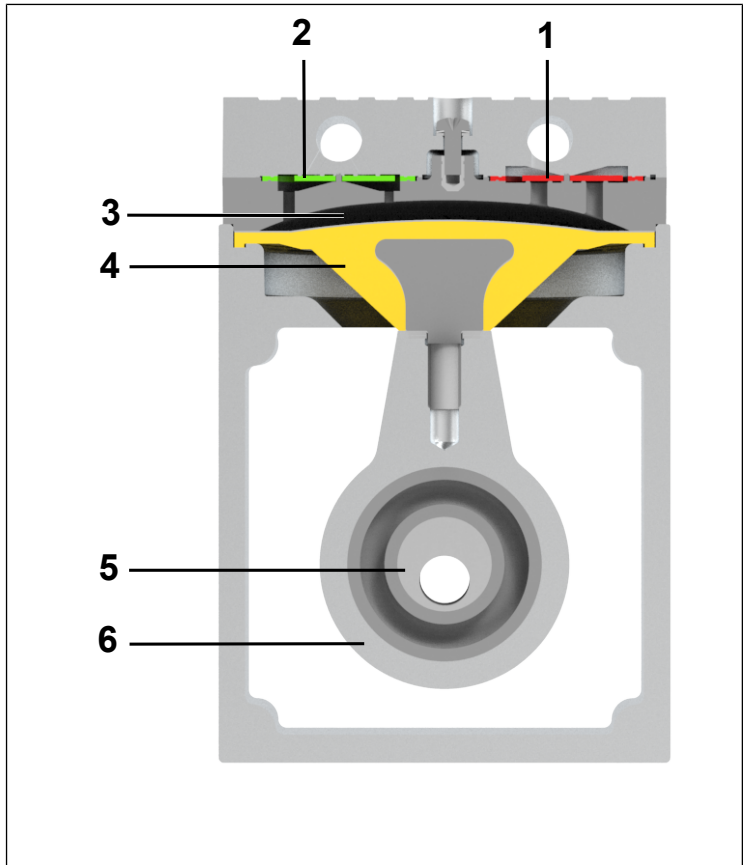

Fig.2: Design N838.1.2\_DC-B (MI)

## Function of a diaphragm pump

- 1 Outlet valve
- 2 Inlet valve
- 3 Transfer chamber
- 4 Diaphragm
- 5 Eccentric
- 6 Connecting rod



*Fig. 3: Function of a diaphragm pump*

Diaphragm pumps transfer, compress (depending on the version) and evacuate gases and vapors.

The elastic diaphragm (4) is moved up and down by the eccentric (5) and the connecting rod (6). In the downwards stroke, it aspirates the gas to be transferred via the inlet valve (2). In the upwards stroke, the diaphragm presses the medium out of the pump head via the outlet valve (1). The transfer chamber (3) is separated from the pump drive by the diaphragm.

## 5 Transport

### General

---



#### CAUTION

Personal injury and/or property damage due to incorrect or improper transport of the pump

In the event of incorrect or improper transport, the pump can fall down, be damaged or injure persons.

- Use suitable auxiliary means if necessary (carrying strap, lifting gear, etc.).
  - Where appropriate, wear suitable personal protective equipment (e.g., safety shoes, safety gloves).
- 



#### CAUTION

Risk of injury from sharp edges on the packaging

There is a risk of injury from cutting on the sharp edges when grabbing corners or when opening the packaging.

- Where appropriate, wear suitable personal protective equipment (e.g., safety shoes, safety gloves).
-

Only for two-headed pumps:



Personal injury and/or property damage due to incorrect or improper transport of the pump

If the pump is raised and/or carried on the connection during transport, leaks and/or damages to the pump may result.

→ Do not carry the pump on the pneumatic connection.

- Transport the pump in the original packaging to the installation location.
- Keep the original packaging of the pump (e.g. for later storage).
- Inspect the pump for transport damage after receiving it.
- Document any transport damage that has occurred.
- Remove any transport safeguards on the pump prior to commissioning.

### Parameter

Parameter	Value
Storage temperature [°C]	+ 5 to + 40
Transport temperature [°C]	- 10 to + 60
Permissible humidity (non-condensing) [%]	30 to 85

Tab. 14: Transport parameters and storage parameters



### Damage to the pump

Commissioning at an insufficient temperature can lead to malfunctions or damage to the pump.

- Prior to commissioning, make sure that the pump has reached the ambient temperature (3 *Technical data* [▶ 15]).

## 6 Installation and connection

Only install the pumps in accordance with the operating parameters and conditions described in Chapter 3 *Technical data* [▶ 15].

→ Observe the safety instructions (see Chapter 2 *Safety* [▶ 8]).



Damage due to foreign objects entering the pump

During installation and/or subsequent operation of the pump, foreign bodies may enter and damage the pump.

→ Take protective measures against allowing foreign objects to enter the pump.



Risk of dangerous gas mixtures during pump operation

Depending on the medium being transferred, breakage of the media-contacting components can result in a dangerous mixture if the medium mixes with the air in the compressor housing or the surroundings.

→ Before using a medium, check the compatibility of the media-contacting components (see 3 *Technical data* [▶ 15]) with the medium.

---

### 6.1 Installing the pump

→ Store the pump at the installation location to allow it to adapt to the ambient temperature before installation (condensation must not be allowed to form).

Mounting dimensions → For mounting dimensions, see the following figures:

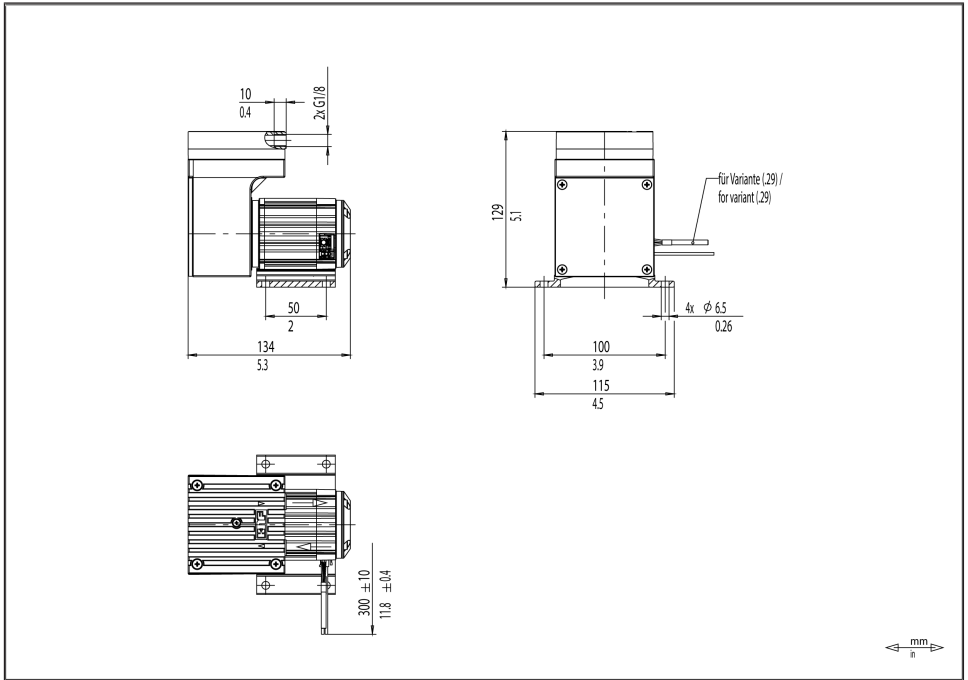

Fig. 4: Mounting dimensions N838\_DC-B

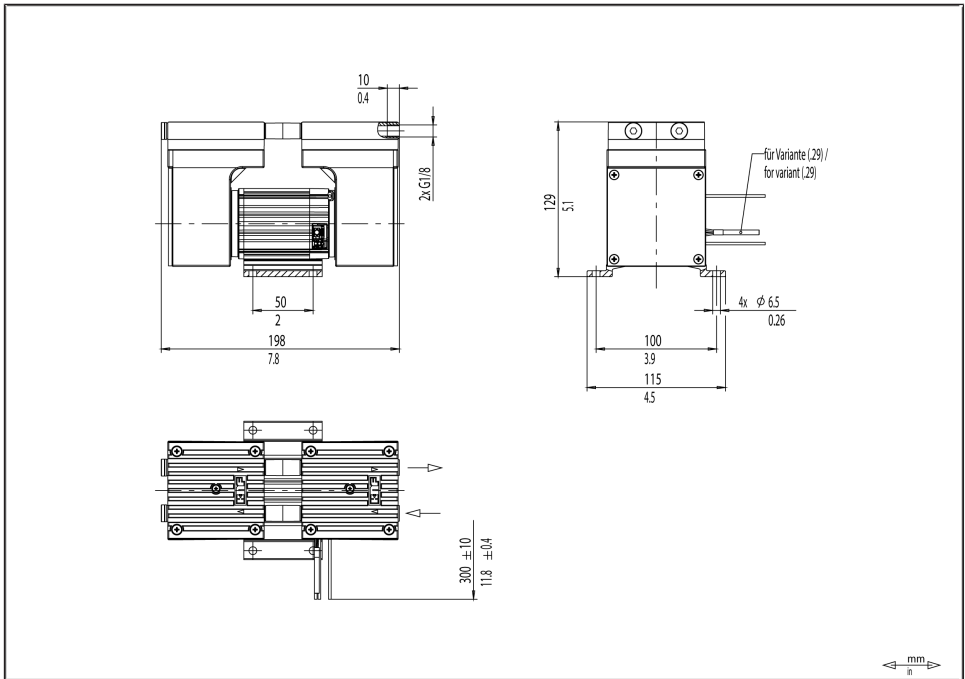

Fig. 5: Mounting dimensions N838.1.2\_DC-B

Cooling air supply



**WARNING**

Danger of burning on hot surfaces

Hot surfaces could occur if the pump overheats.

→ When installing the pump, make sure that sufficient cooling air in-feed and discharge is ensured.

Proximity to hot pump parts

→ During installation, make sure that no combustible or thermally deformable objects are positioned in proximity to hot pump parts (head, motor).

Installation location

→ Make sure that the installation location is dry and that the pump is protected from rain, spray water, splash water, dripping water and other contamination.

→ Make sure the installation location allows access for servicing.

- Make sure that access to moving parts is prevented.
  - i** The IP protection class of the pump motor is specified on the type plate.
  - Install the pump at the highest point in the system to prevent condensate from collecting in the pump head.
  - Protect the pump from dust.
  - Protect the pump from coating with greases and oils.
  - Protect the pump from vibration and impact.
- Installation position
- The pump can be operated in any installation position. Use metal screws to fasten the pump at the indicated attachment points. Observe the specifications of the selected fasteners.



Personal injury and/or property damage from vibrations

Pump vibrations, in combination with adjacent components, can result in crushing and/or damage to these components.

- Make sure that pump vibrations cannot lead to dangers in combination with adjacent components.

Protection against foreign objects

- Protect the pump against contact and the ingress of foreign bodies.



Risk of injury during operation

Touching electrical, hot or moving parts of the pump during installation can cause injuries.

- Take protective measures against touching the electrically live parts (electrical connection, motor windings if applicable).
- Take protective measures to safeguard against touching moving and hot parts.
- Automatic restart after tripping of the self-resetting protection temperature limiter.



Risk of pump damage during operation

During installation and/or subsequent operation of the pump, foreign bodies may enter and damage the pump.

- Take protective measures against allowing foreign objects to enter the pump.

## 6.2 Electrical connection

---



Risk of death due to electric shock

Improper electrical connection of the pump can result in electric shocks, which can lead to serious injury or even death.

- Only have the pump connected by specialized personnel.
- Only have the pump connected if the power supply is disconnected.

- 
- For electrical connection to a power source, observe the applicable standards, regulations, directives, and technical standards.
  - The pumps have been developed, manufactured and tested for S1 operation.  
Additional operating modes can be made possible on a project-specific basis following consultation with KNF Customer Service.
  - Install a device for separating the pump motor from the electrical grid in the electrical installation (e.g. in accordance with EN 60335-1).
  - KNF recommends operating the motors with a SELV or PELV power supply.  
Depending on the customer's device, we recommend connecting the housing to ground.
  - i** Refer to the type plate for the maximum current consumption of the pump.
  - Install an Emergency Off device such that it is not possible for there to be an automatic restart or for hazardous situations to persons and property to occur.
  - Install the pumps in such a way that it is not possible to touch electrically live parts (electrical connection).

- Fastening the connection cables → Fasten the connection cables so that
- the cables do not come into contact with movable or hot parts.
  - the cables cannot be worn or damaged on sharp corners or edges.
  - no tensile and pressure forces are exerted on the connection point of the cables (strain relief).

### Connecting the pump

1. Confirm that the power supply meets the parameters listed on the pump type plate. Refer to the pump type plate for the rated current draw.
2. Connect the positive and negative terminals.

**i** Ensure the correct polarity:  
 Red connection cable: +  
 Black connection cable: -

**i** For plug specifications, see chapter 12.2 *Supply connector* [▶ 68] and chapter 12.3 *Signal connector* [▶ 69].

## 6.3 Pneumatic connection



Personal injury or property damage through ejected plugs

If not removed, the plugs on the outlet of the pump can be ejected during operation by the resulting overpressure.

- Remove the plugs during installation.
- Wear appropriate personal protective equipment.

- Connected components → Only connect components to the pump that are designed for the pneumatic data and thermal requirements of the pump. (see Chapter 3 *Technical data* [▶ 15]).

- Pump discharge → Discharge the possibly hot pump discharge at the pneumatic outlet of the pump safely (with regard to medium and noise).
- Decoupling → KNF recommends mechanically decoupling the pump from the pipe system, e.g., through the use of flexible hoses or pipes. In this way it is possible to prevent the transfer of possible pump vibrations and noises to the system.

### Connecting the pump

**i** A marking on the pump head indicates the flow direction.



Risk of injury due to mixing up inlet and outlet

Mixing up the inlet and outlet may cause breakage of components connected at the inlet and outlet.

→ Observe the marking of inlet and outlet on the pump head.

- 
1. Remove the protective plugs from the connections.
  2. Screw accessories such as silencers or hose nipples (if present) onto the corresponding connections.
- i** The silencer is to be mounted in the outlet of the pump.
3. Connect the suction line and the pressure line (for mounting dimensions, see Chapter 3 *Technical data* [p. 15]).
  4. Lay the suction line and pressure line with a descent so that no condensate can run into the pump.

## 7 Operation

### 7.1 General

---



Risk of burns from hot pump parts and/or hot medium

Some pump parts may be hot during or after operation of the pump.

- Allow the pump to cool after operation.
  - Take protective measures to protect against touching hot parts.
- 



Injury to eyes

Coming too close to the inlet/outlet of the pump may result in injury to the eyes due to the present vacuum/operating pressure.

- Do not look into the pump inlet/outlet during operation.
- 

- Only operate the pumps under the operating parameters and operating conditions as described in Chapter 3 *Technical data* [▶ 15].
- Ensure the proper use of the pumps (See Chapter 2.6.1 *Proper use* [▶ 12]).
- Rule out the possibility of foreseeable misuse of the pumps (see chapter 2.6.2 *Foreseeable misuse* [▶ 12]).
- Observe the safety instructions (Chapter 2 *Safety* [▶ 8]).
- The pumps are built-in devices. Before they are commissioned, it must be ensured that the machines or systems into which the pumps are installed comply with the relevant provisions.



Risk of bursting of pump head due to excessive pressure increase

Excessive pressure increase during pump operation can cause the head to burst, resulting in material damage or personal injury.

- Do not exceed the maximum permissible operating pressure (see 3 *Technical data* [▶ 15]).
- Monitor the pressure during operation.
- If the pressure exceeds the maximum permissible operating pressure of the pump: immediately switch off the pump and remedy the fault (see Chapter 10 *Troubleshooting* [▶ 61]).
- Only throttle or regulate the air or gas quantity on the inlet line to prevent the maximum permissible operating pressure from being exceeded.
- If the air quantity or gas quantity on the outlet line is throttled or regulated, make sure that the maximum permissible operating pressure at the pump is not exceeded.
- Ensure that the pump outlet is not closed or restricted.



Material damage due to excess pressure

Exceeding the maximum permissible operating overpressure can result in material damage to the pump.

- Excessive pressure, with all of the associated hazards, can be prevented by means of a bypass line with a pressure relief valve between the outlet and inlet of the pump. Further information is available from KNF Customer Service (contact data: see [www.knf.com](http://www.knf.com)).



Risk of dangerous gas mixtures during pump operation if diaphragm breaks

If the diaphragm should break, the medium will mix with the air in the compressor housing or in the surroundings.

- Stop pump immediately.
- Replace the diaphragm prior to further operation (see Chapter 8 *Servicing* [▶ 39]).



Material damage due to intake of contaminants and objects

Operation with open gas connection at the inlet can result in contaminants and objects being drawn in.

- If necessary, take protective measures against the ingress of contaminants and objects.

- Pump standstill → When the pump is at a standstill, establish normal atmospheric pressure in the lines.
- Vapors as medium The service life of the diaphragm can be extended, if no condensate forms in the pump. Therefore:
- Perform any work with saturated or near-saturated vapors only with a warm pump.
  - KNF recommends: When pumping corrosive media, flush the pump before switching off (see Chapter 8.2.1 *Flushing the pump* [▶ 40]) to extend the service life of the diaphragm.

## 7.2 Information on switching the pump on and off

### Switching on the pump

- Ensure that normal atmospheric pressure is present in the lines when switching on.

### Switching off/decommissioning the pump

- Establish normal atmospheric pressure in the lines (relieve pump pneumatically).
- Recommissioning → Before recommissioning, observe the applicable standards, guidelines, regulations and technical standards at the electrical connection.
- Inspecting the pump → Inspect the pump periodically for external damage or leakage.

## 7.3 Speed specification [.29 version]

The pump can be actuated by analog or digital means. The speed setpoint of the pump can be carried out by one of three options:

- 12.4 *Analog control voltage* [▶ 71],
- 12.5 *PWM setpoint setting* [▶ 71],
- 12.6 *Digital setpoint setting* [▶ 72].
- As an option, it is possible to have the speed set to a fixed value by the manufacturer. In this case, the pump does not need any speed setting signals.

A standard-analog configured pump can be switched to digital mode at any time with the start command "dU" via the UART interface. The pump then remains in this mode until it is actively disconnected from the supply voltage.

Functional status parameters can be read out via the UART interface at any time, even if the setpoint is set using analog voltage.

## 8 Servicing



### Servicing the pump

Damage to the pumps can result from failure to observe the applicable legal regulations and procedures for the location or intervention by untrained or uninstructed personnel.

- Servicing may only be performed according to the legal regulations (e.g. work safety, environmental protection) and provisions.
- Servicing may only be performed by specialized personnel or trained and instructed personnel.

### 8.1 Servicing schedule

Component	Maintenance interval
Pump	<ul style="list-style-type: none"> <li>→ Perform periodic inspections for external damage or leakage.</li> <li>→ Perform periodic inspections for noticeable changes to noises and vibrations.</li> </ul>
Gas connections	<ul style="list-style-type: none"> <li>→ Perform periodic inspections for external damage or leakage.</li> </ul>
Diaphragm and valve plates	<ul style="list-style-type: none"> <li>→ At the latest, replace when the pump flow rate decreases.</li> </ul>
Silencer (accessories)	<ul style="list-style-type: none"> <li>→ Replace if soiled.</li> </ul>

Tab. 15: Servicing schedule

## 8.2 Cleaning

---



Material damage due to cleaning work  
Failure to observe the cleaning instructions may result in material damage to the device if liquids penetrate the inside of the housing.

- Ensure that no fluids enter the interior of the housing.
- 

### 8.2.1 Flushing the pump

When transferring dangerous and environmentally hazardous media, KNF recommends flushing the pump with air at atmospheric pressure for a few minutes prior to switch-off (if necessary for safety reasons: with an inert gas) to extend the service life of the diaphragm.

- Discharge the media safely.

### 8.2.2 Cleaning the pump

Requirements → Pump disconnected from mains and voltage-free

---



Risk of burns from hot pump parts  
The pump head or motor may still be hot after operation of the pump.

- Allow the pump to cool after operation.
-



Health hazard due to dangerous substances in the pump

Depending on the medium being transferred, caustic burns or poisoning is possible.

- Wear protective equipment if necessary, e.g., protective gloves, goggles.
- Clean the pump with suitable measures.



Material damage due to entry of liquids

When cleaning the pump, liquids may enter the inside of the housing, which can damage the pump.

- During cleaning work, ensure that no fluids enter the interior of the housing.

- Only clean the pump with a dry wiping cloth. When cleaning, use no solvents if possible as these can affect the plastic parts.
- Only use solvents during cleaning if head materials are not corroded (ensure resistance of the material).
- If compressed air is available, blow out the components.

### 8.3 Replacing the diaphragm and valve plates

- Requirements
- Disconnect the motor from the power supply network and ensure that it is voltage-free.
  - Allow the pump and the motor to cool.
  - Clean the pump and remove any hazardous materials from the pump.

→ Remove the hoses/pipes from the inlet and outlet of the pump.

Spare parts/tools

Spare part/tool	Quantity
Spare part set*	1
Felt-tip pen	1
Size 2 Phillips screwdriver	1

Tab. 16: Spare parts/tools

\*Acc. to 9 Spare parts and accessories [▶ 59]

Information on the procedure

Diaphragm and valve plates/seals are the only wearing parts in the pumps. They are easy to replace.

Valve plates/seals and diaphragm should generally be replaced at the same time. If the diaphragm is not replaced at the same time as the valve plates/seals, the specified output of the pump can no longer be ensured after the maintenance is performed.



Health hazard due to dangerous substances in the pump

Depending on the medium being transferred, caustic burns or poisoning is possible.

- Wear protective equipment if necessary, e.g., protective gloves, goggles.
- Clean the pump with suitable measures.



Risk of burns from hot pump parts

The pump head or motor may still be hot after operation of the pump.

- Allow the pump to cool after operation.

### 8.3.1 Replacing diaphragm and valves

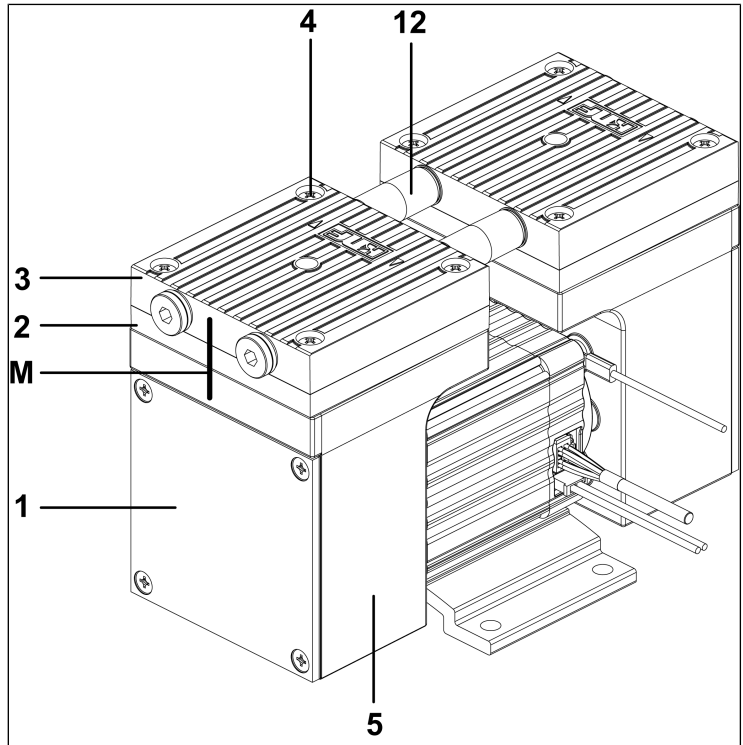

Fig.6: Pump N838.1.2\_DC-B

- 1 Cover plate
- 2 Intermediate plate
- 3 Head plate
- 4 Head plate screw
- 5 Housing
- 6 Valves
- 7 Structured diaphragm
- 8 Shim
- 9 Screw
- 10 Spring washer
- 11 Shim
- 12 Pneumatic connection tube
- M** Marking

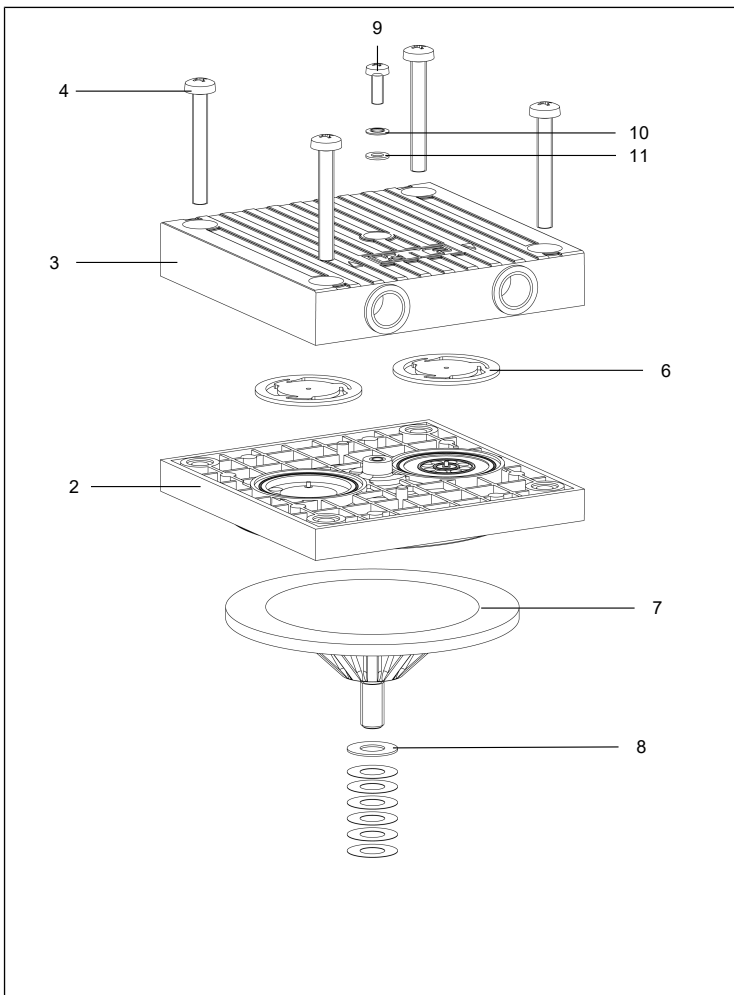
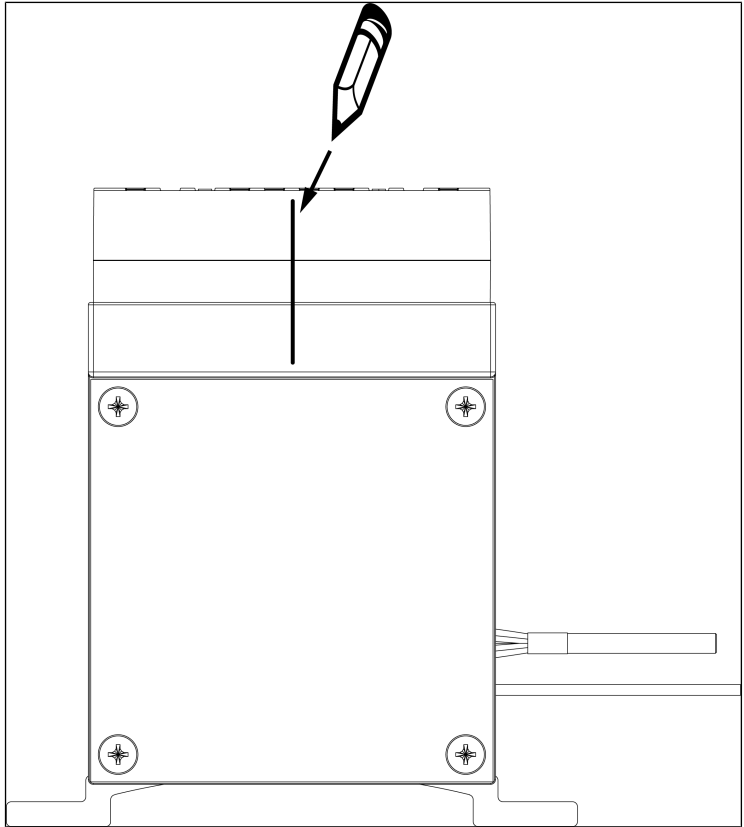

Fig.7: Pump head N838KN\_Versions

**Initial steps**

1. Disconnect the pump from the power supply and ensure that it is voltage-free.



*Fig.8: Marking of the pump*

2. Mark the head plate (3), the intermediate plate (2) and the housing (5) with a continuous felt-tip pen line (M). This helps to avoid incorrect assembly later.

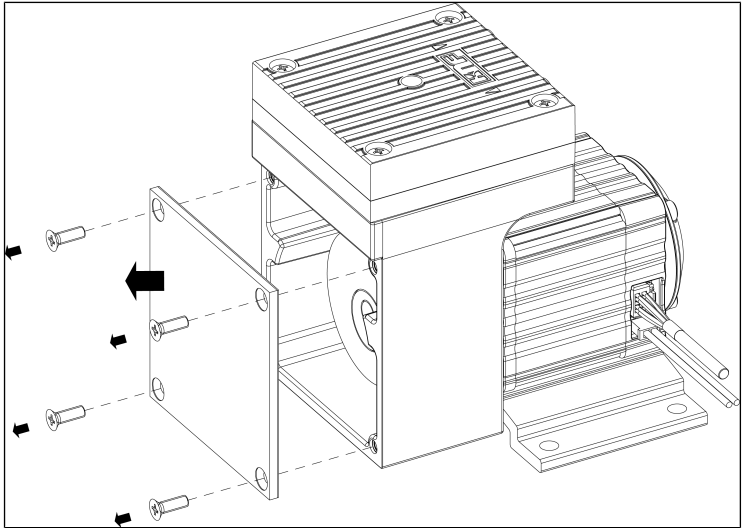

*Fig.9: Remove screws and cover plate*

3. Loosen the four fastening screws and remove the cover plate (1).

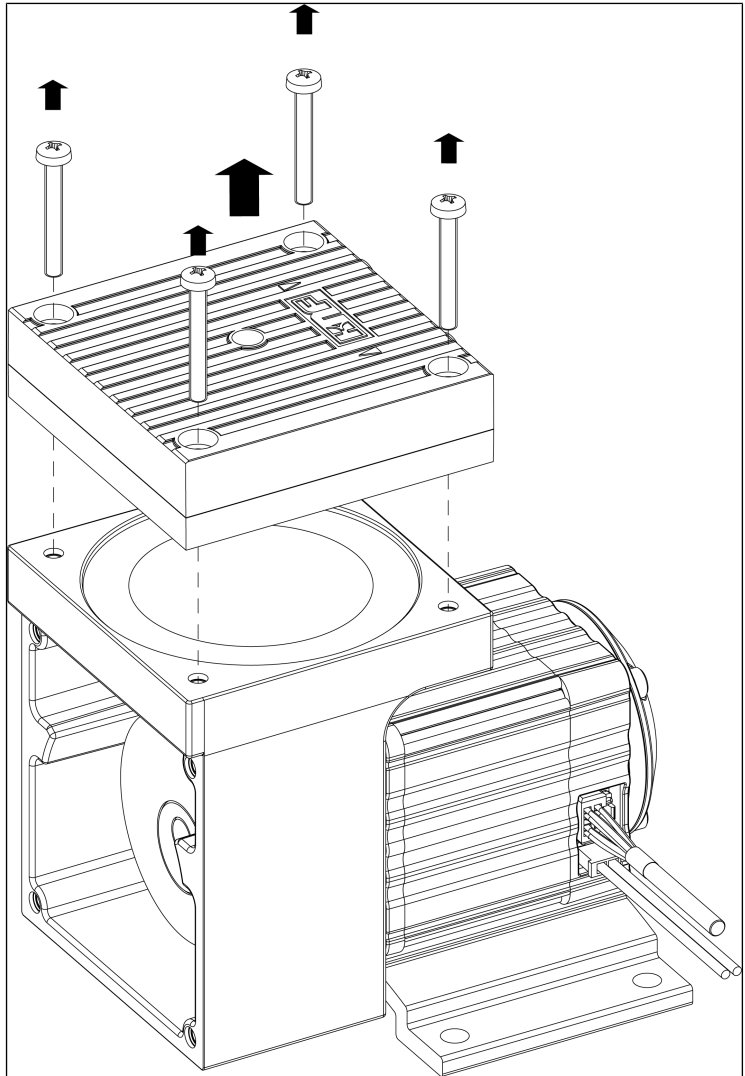
**Remove pump head**

*Fig.10: Remove screws and head plate*

1. Loosen the four head plate screws (4) and remove the head plate (3) from the pump housing together with the intermediate plate (2).

2. For two-headed pumps:  
Loosen the head plate screws (4) on both pump heads and remove both head plates (3) together with the connection (13) and the intermediate plate (2).

### Changing the diaphragm

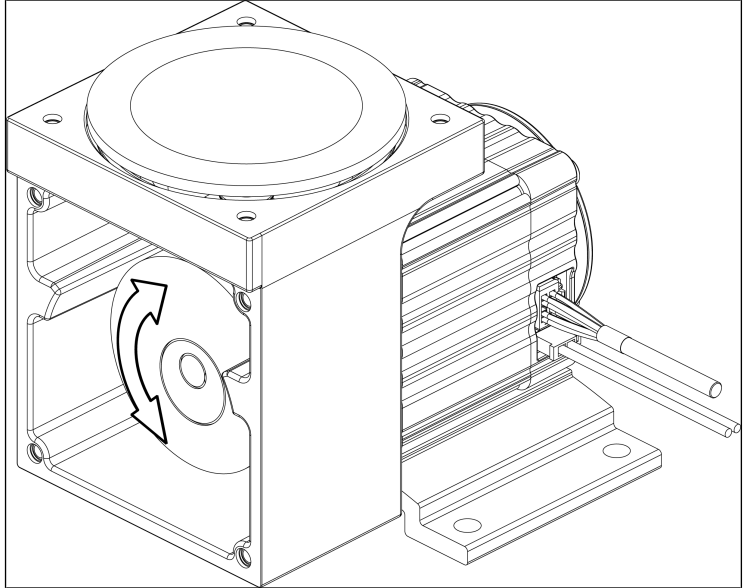

*Fig.11: Turn counterweight*

1. Turn the counterweight to move the diaphragm (7) to the upper reversal point.

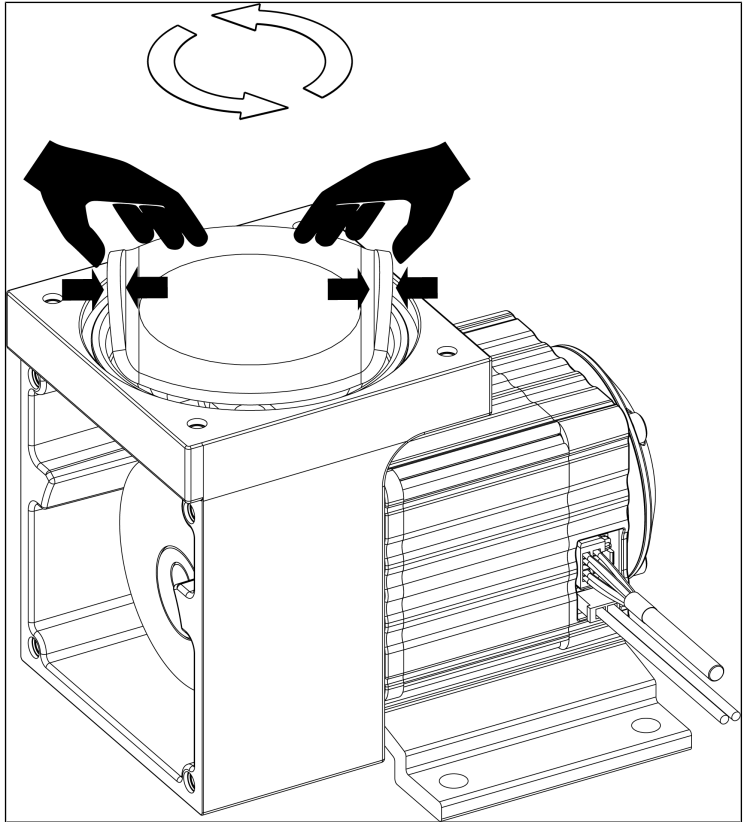

*Fig.12: Unscrew diaphragm*

2. Lift the diaphragm (7) on opposing side edges. Then grasp the diaphragm (7) and loosen it by turning it counterclockwise.

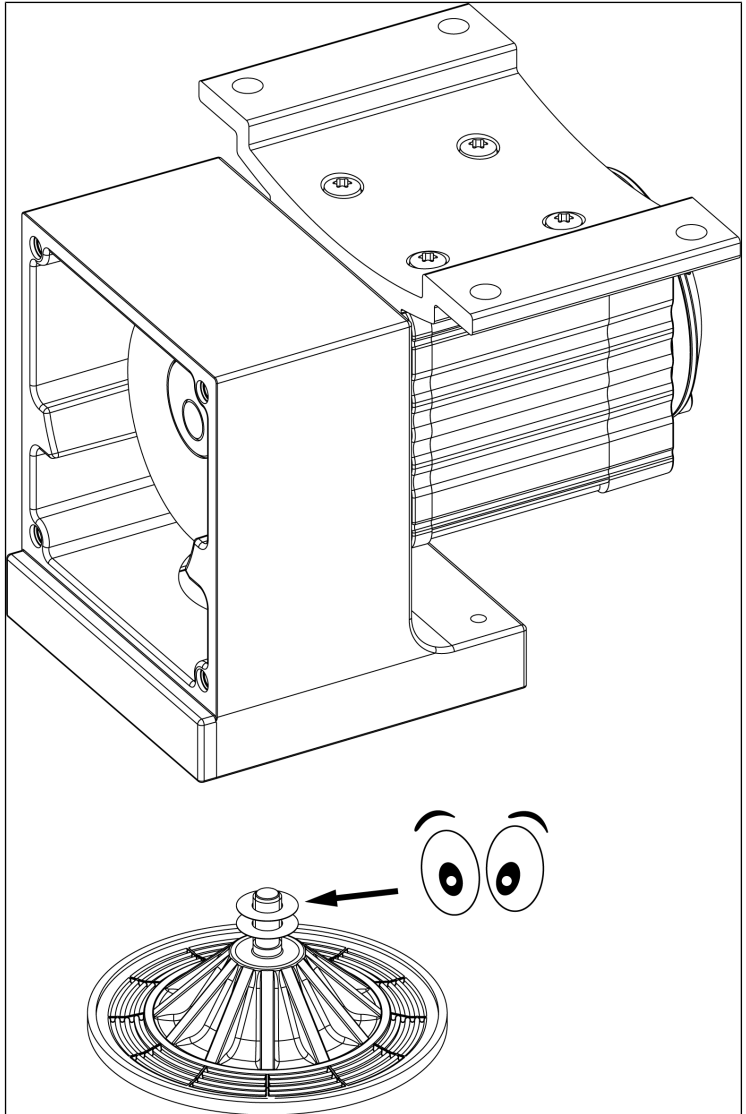

*Fig.13: Shims on diaphragm*

3. Turn the pump over.
4. Unscrew the diaphragm (7) together with the shim(s) (8).



Material damage due to shim(s) falling into the pump housing

When removing the diaphragm, ensure that no shim(s) fall into the pump housing, as these can damage the pump when it is put back into operation.

- Make sure that the shim(s) do not fall into the pump housing.
- When removing the diaphragms, remove and set the shim(s) aside for safe keeping.
- When remounting, use the exact same number of shim ring(s).

- 
5. Remove the shim(s) **(8)** from the threaded bolt of the diaphragm **(7)** and keep them in a safe place.
  6. Check all parts for contamination and clean them if necessary (see *8.2.2 Cleaning the pump* [▶ 40]).
  7. Push the shim(s) **(8)** onto the threaded bolt of the new diaphragm **(7)**.
  8. Turn the pump over again.
  9. Move the connection rod to the upper reversal point by turning the counterweight.

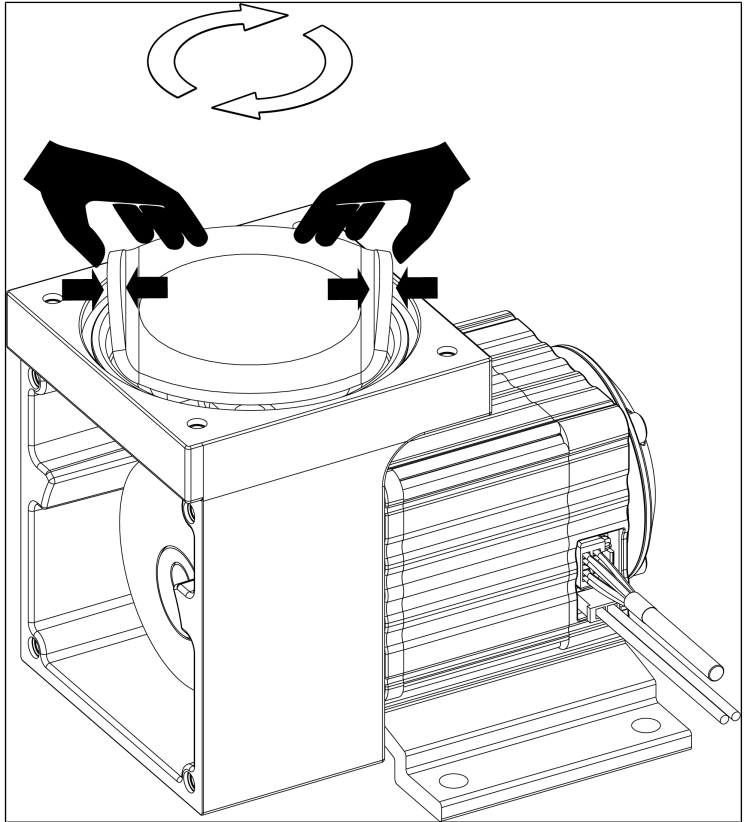

*Fig.14: Screw in diaphragm*

10. Screw the diaphragm (7) with shim(s) (8) clockwise onto the connection rod and finger-tighten.
11. For two-headed pumps:  
Perform steps 1 to 7 for the second pump head.

## Changing valves

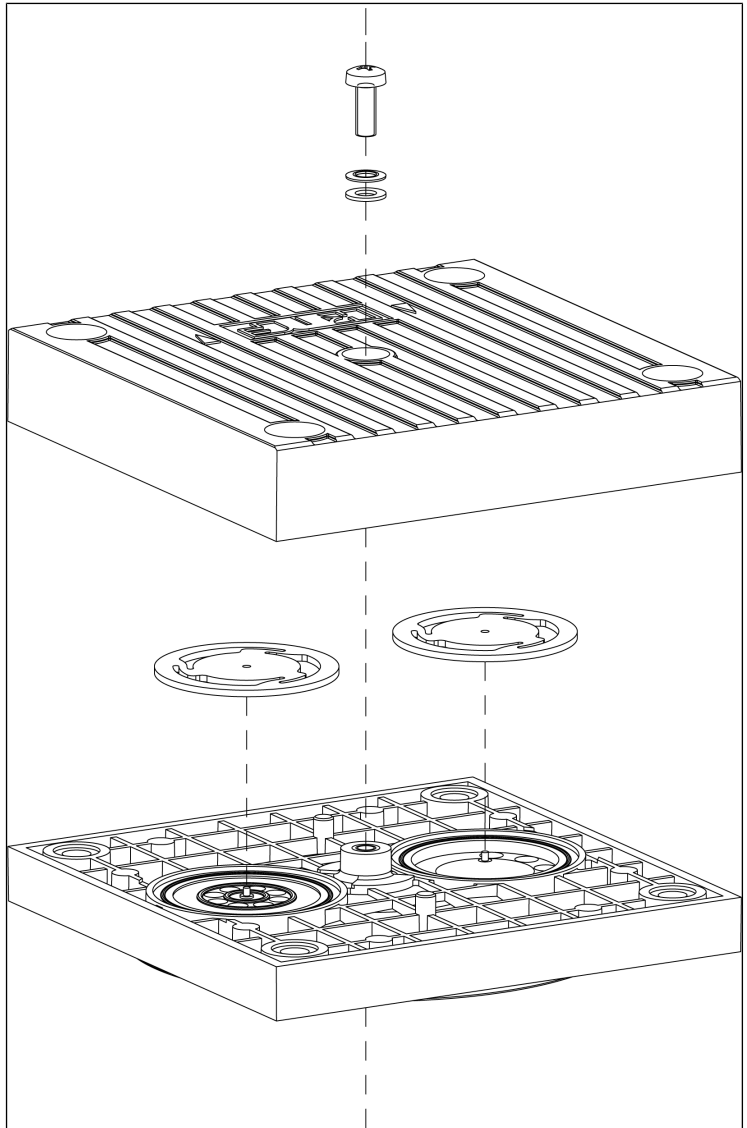

*Fig.15: Changing valves*

1. Loosen the screw **(9)** with a small screwdriver.
2. Separate the head plate **(3)** from the intermediate plate **(2)**.

3. Remove the valves (6) from the intermediate plate (2).
  4. Check the valve seats, intermediate plate and head plate for cleanliness; Replace these parts if there are bumps and scratches on them.
- i** The valves and O-rings for the outlet and inlet are identical; the same applies for the top and bottom of the valves and O-rings.
5. Insert the new valves (6) in the valve seats of the intermediate plate (2).
  6. By slightly moving the valves horizontally, ensure that they are not under tension.
  7. Place the head plate (3) on the intermediate plate (2) according to the marking (M).
  8. With a slight lateral movement of the head plate, check its centering.
  9. Connect the head plate (3) and the intermediate plate (2) to each other; to do this, screw in the screws (9) with spring washer (11) and shim (12). Tightening torque for tightening the screws: 35 Ncm.
  10. Mount the screw covers (10).
  11. For two-headed pumps:  
Perform steps 1 to 9 for the second pump head.

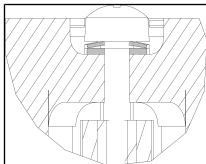

Fig. 16: Alignment of the spring washers (11)

### For two-headed pumps: Change O-rings on connection tube

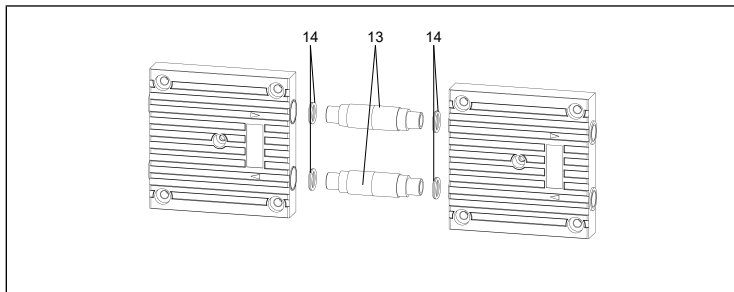

Fig. 17: Removal of connection tubes and O-rings (two-headed pumps)

12. Pull the two pump heads apart and remove the connection tubes (13) with the O-rings (14).

13. Change the O-rings on both connection tubes.
14. Put the connection tubes with the new O-rings(14) back into the two pump heads.

### Mounting the pump head

- i** For two-headed pumps, the following steps must be performed on both pump heads at the same time.

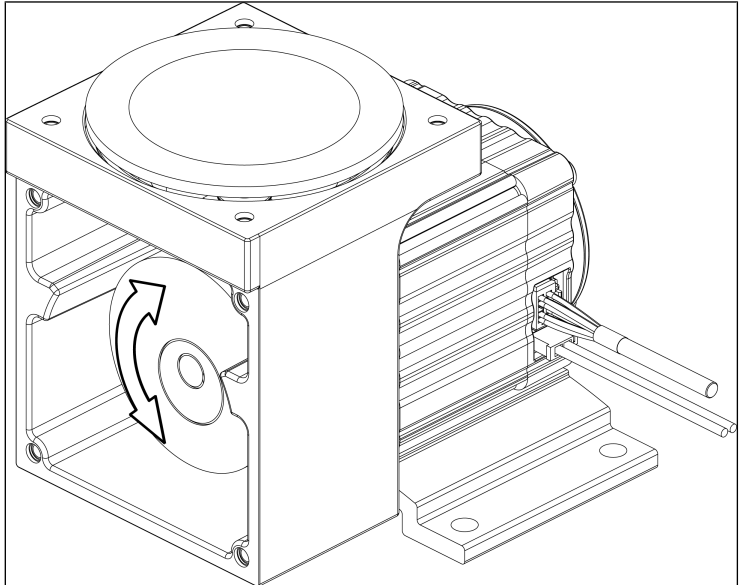

*Fig. 18: Turn counterweight*

1. Move the diaphragm via the counterweight to top dead center.

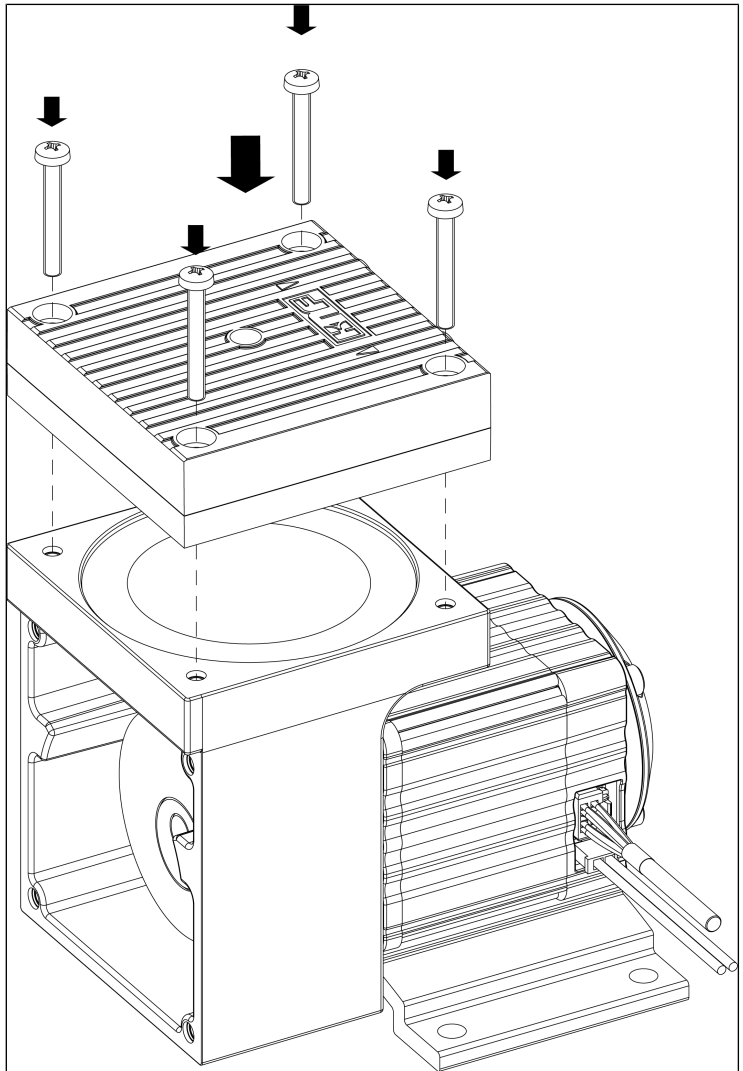

*Fig. 19: Fit screws and head plate*

2. Place the pump head(s) (consisting of intermediate plate (2) with valves (6) as well as head plate (3)) on the housing according to the markings (M).
3. Only slightly tighten the screws (4) crosswise.

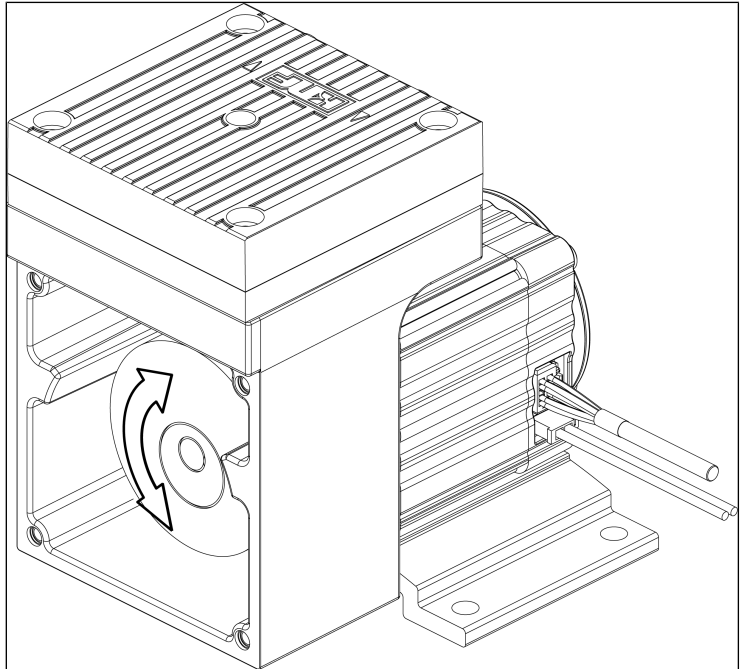

*Fig. 20: Check ease of movement*

4. Check for ease of movement of the pump by turning the counterweight.
5. Move the diaphragm via the counterweight to top dead center.
6. Finger-tighten the screws (4) crosswise (tightening torque: 3.5 Nm).

## Final steps

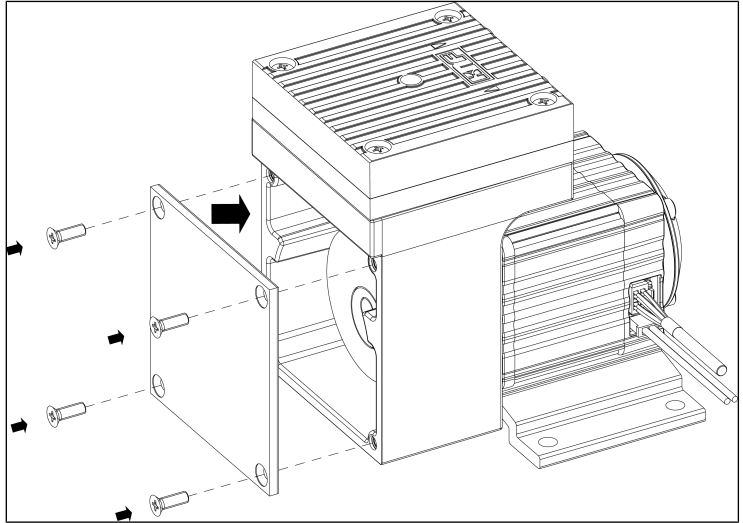

*Fig. 21: Fasten screws and cover plate*

1. Mount the cover plate (1).
2. Connect the pump to the power supply.

If you have questions with regard to maintenance, please contact our KNF Customer Service (contact data: [www.knf.de](http://www.knf.de)).

## 9 Spare parts and accessories

**i** To order spare parts and accessories, please contact your KNF sales partner or KNF Customer Service (contact data: see [www.knf.com](http://www.knf.com)).

### 9.1 Spare parts

#### Spare part set

A spare part set consists of:

For one-headed pumps:

Spare part	Quantity
Diaphragm	1
Valves	2

Tab.17:

For two-headed pumps:

Spare part	Quantity
Diaphragm	2
Valves	4
O-rings	4

Tab.18:

Spare part set	Order number
N 838 (one head)	043825
N 838.1.2 (two-headed)	313749

Tab.19:

## 9.2 Accessories

Accessories	Order number
Silencer G 1/8	007006
Hose connector (straight) Except N838.1.2KN_ : PA, G 1/8, ID6	000360
Hose connector N838.1.2 KN_ : PA, G 1/8, ID8	004975
Angled hose connector Except N838.1.2KN_ : PA, G1/8, ID6	001858
Accessory set (anti-vibration buffers)	358342

Tab.20:

## 10 Troubleshooting

---



Risk of death due to electric shock

Working on the pump connected to the power supply can result in electric shocks, which can lead to serious injury or even death.

- All work on the pump may only be performed by authorized specialized personnel.
- Before working on the pump: Disconnect the pump from the power supply.
- Check and ensure that no voltage is present.

- 
- Allow the pump to cool before troubleshooting.
  - Check the pump (see following tables).

<b>Pump not delivering</b>	
<b>Cause</b>	<b>Troubleshooting</b>
Pump is not connected to the electrical power supply.	→ Connect the pump to electrical power supply.
No voltage in the electrical power supply.	→ Check the circuit breaker for the room and switch it on if necessary.
Pneumatic connections or lines are blocked.	→ Check the connections and lines. → Remove the blockage.
External valve is closed or filter clogged.	→ Check external valves and filters.
Condensate has collected in the pump head.	→ Separate the source of the condensate from the pump. → Flush the pump with air at atmospheric pressure for a few minutes (if necessary for safety reasons: with an inert gas). → Install the pump at the highest location in the system.
Fault on drive controller.	→ *See Chapter 12.9 <i>Troubleshooting</i> [▶ 79].
Overcurrent protection of the motor control board tripped Maximum temperature of the motor control board exceeded Maximum lock time of the rotor exceeded	→ Disconnect pump from mains. → Determine and rectify the cause of the overcurrent, overheating or blocking (e.g., inadmissible pressure conditions, liquid in the pump heads). <b>i</b> The pump must be disconnected from mains for several seconds before the electronics reset.
Incorrect polarity of the connection leads	→ Disconnect pump from electrical mains. → Ensure correct polarity of the connection leads and connect the pump.
Diaphragm and valves are worn or defective.	→ Replace diaphragm and valves (see Chapter 8 <i>Servicing</i> [▶ 39]).

Tab.21: Troubleshooting: Pump not delivering

**Flow rate, pressure or vacuum too low**

**The pump does not reach the performance stated in the technical data or data sheet.**

Cause	Troubleshooting
Condensate has collected in the pump head.	<ul style="list-style-type: none"> <li>→ Separate the source of the condensate from the pump.</li> <li>→ Flush the pump with air at atmospheric pressure for a few minutes (if necessary for safety reasons: with an inert gas).</li> <li>→ Install the pump at the highest location in the system.</li> </ul>
There is overpressure on the pressure side and at the same time vacuum or pressure above atmospheric pressure on the suction side.	<ul style="list-style-type: none"> <li>→ Change the pneumatic conditions.</li> </ul>
Pneumatic lines or connection parts have insufficient cross-sections or are constricted.	<ul style="list-style-type: none"> <li>→ Disconnect the pump from the system to determine the output values.</li> <li>→ Eliminate any constriction (e.g. valve).</li> <li>→ Use lines or connection parts with a larger cross-section if necessary.</li> </ul>
Leaks occur at pneumatic connections, lines or pump head.	<ul style="list-style-type: none"> <li>→ Eliminate the leaks.</li> </ul>
Pneumatic connections or lines are partially or completely blocked.	<ul style="list-style-type: none"> <li>→ Check the pneumatic connections and lines.</li> <li>→ Remove any parts or particles that are causing blockages.</li> </ul>
Head parts are soiled.	<ul style="list-style-type: none"> <li>→ Clean the head components.</li> </ul>
Working diaphragm broken	<ul style="list-style-type: none"> <li>→ Stop the pump immediately.</li> <li>→ Change the diaphragm (see 8 Servicing [▶ 39]).</li> </ul>
Diaphragm and valves are worn or defective.	<ul style="list-style-type: none"> <li>→ Replace diaphragm and valves (see Chapter 8 Servicing [▶ 39]).</li> </ul>
Replaced diaphragm and valves.	<ul style="list-style-type: none"> <li>→ Ensure that shims were fitted on the diaphragm thread.</li> </ul>

<b>Flow rate, pressure or vacuum too low</b>	
<b>The pump does not reach the performance stated in the technical data or data sheet.</b>	
<b>Cause</b>	<b>Troubleshooting</b>
	→ *Check the pneumatic connection and hose connections for leaks.

*Tab.22: Troubleshooting: Flow rate, pressure or vacuum too low*

<b>Pump exhibiting changed running noises and vibrations</b>	
<b>Cause</b>	<b>Troubleshooting</b>
Pump bearing worn or defective.	→ Determine the cause. → Contact KNF Customer Service.

*Tab.23: Troubleshooting: Pump exhibiting changed running noises and vibrations*

**Fault cannot be rectified**

If you are unable to identify any of the specified causes, send the pump to KNF Customer Service (contact data: see [www.knf.com](http://www.knf.com)).

1. Flush the pump with air for a few minutes (if necessary for safety reasons: with inert gas) at atmospheric pressure to free the pump head of dangerous or aggressive gases (see Chapter 8.2.1 *Flushing the pump* [▶ 40]).
2. Clean the pump (see Chapter 8.2.2 *Cleaning the pump* [▶ 40]).
3. Send the pump together with completed Health and Safety Clearance and Decontamination Form to KNF, specifying the pumped medium.

# 11 Returns

## Preparing for return

1. Flush the pump with air for a few minutes (if necessary for safety reasons: with inert gas) at atmospheric pressure to free the pump head of dangerous or aggressive gases (see Chapter 8.2.1 *Flushing the pump* [▶ 40]).  
**i** Please contact your KNF sales partner if the pump cannot be flushed due to damage.
2. Remove the pump.
3. Clean the pump (see Chapter 8.2.2 *Cleaning the pump* [▶ 40]).
4. Send the pump together with the completed Health and Safety Clearance and Decontamination Form to KNF, stating the nature of the transferred medium.
5. Pack the device securely to prevent further damage to the product. If necessary, request original packaging for a fee.

## Returns

KNF shall undertake to repair the pump only under the condition that the customer presents a certificate regarding the medium that is pumped and the cleaning of the pump. In this case too, old devices can be returned. Please follow the instructions at [knf.com/repairs here](http://knf.com/repairs).

Contact your KNF sales partner directly if you require additional support for your return service.

## 12 Appendix MI motors

### 12.1 Technical data

#### Maximum electrical values

Parameter	Value
Minimum signal voltage [V]	-0.3
Maximum signal voltage [V]	5.2
Maximum output current per signal [mA]	5
Input impedance [kΩ]	5
Logical 1 level [V]	2.9...5
Logical 0 level [V]	0...0.4
Max. cable length [m]	≤ 3

*Tab.24: Maximum electrical values*



**Damage to the motor electronics**

Failure to observe the maximum electrical values may result in damage to the electronics of the motor.

- Observe the maximum electrical values of the motor (see chapter 12.1 *Technical data* [▶ 66]).

**Direction of rotation**

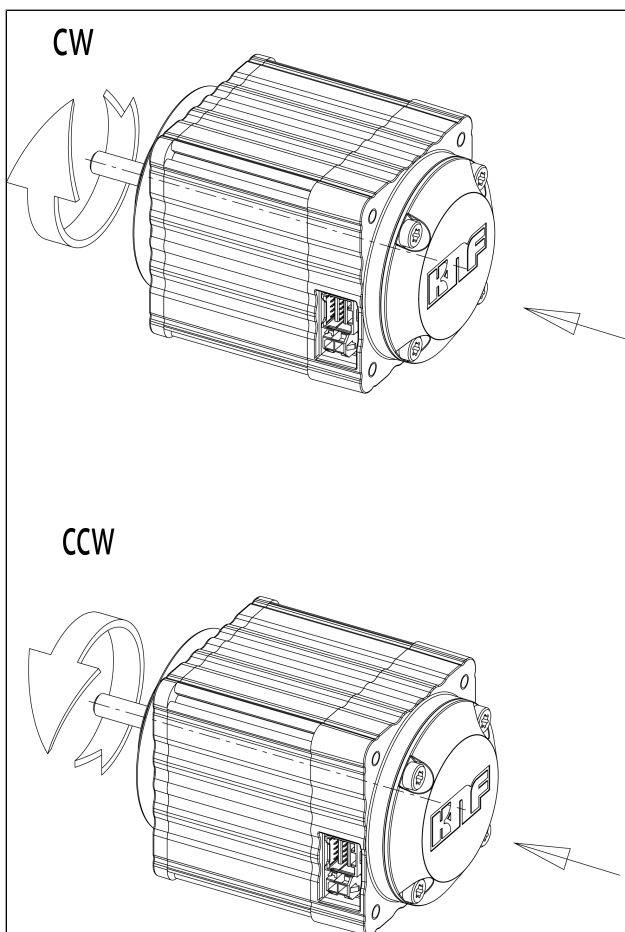

*Fig. 22: KNF motor direction of rotation*

## 12.2 Supply connector

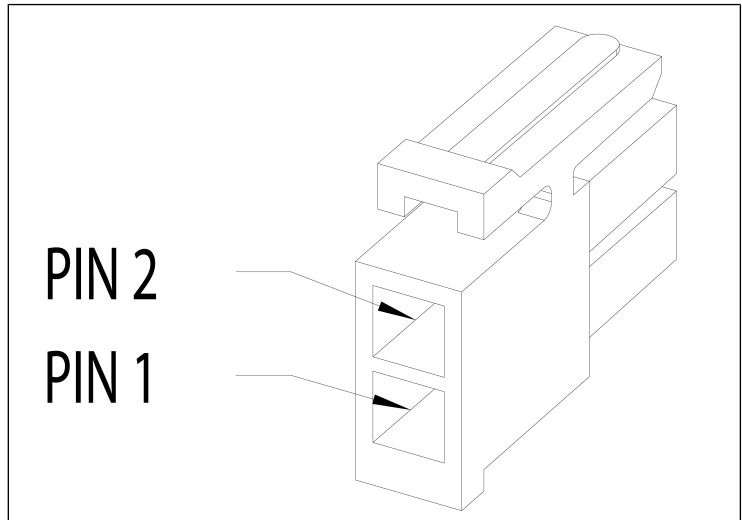

Fig.23: Supply connector

Designation	Manufacturer	Type (manufacturer)
Connector housing	Amphenol	10132445-02LF
Crimp contact	Amphenol	10132447-111PLF
Cable	-	AWG 18, $\geq 105^{\circ}\text{C}$ Cable length $\leq 3\text{m}$

Tab.25: Supply connectors

Pin number	Color	Description
1	Black	Voltage supply GND
2	Red	Voltage supply 24 V

Tab.26: Pin assignment for supply connector

### 12.3 Signal connector

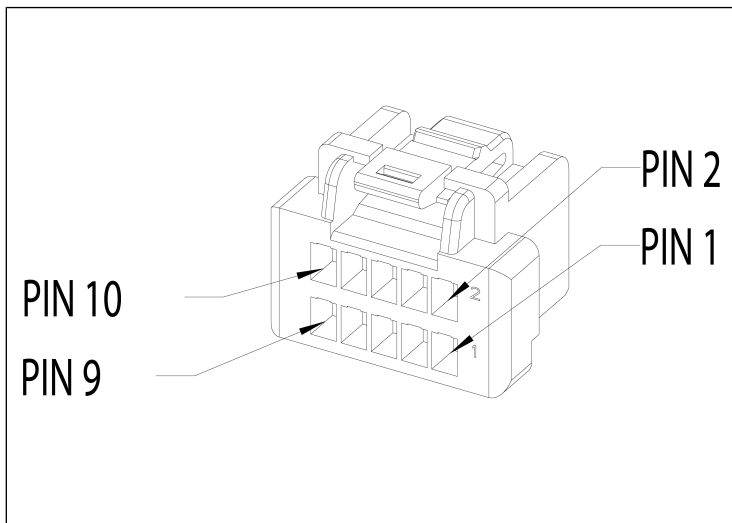

Fig.24: Signal connector

Designation	Manufacturer	Type (manufacturer)
Connector housing	Amphenol	5031491000
Crimp contact	Amphenol	5025790000
Cable	-	AWG 24, $\geq 105^{\circ}\text{C}$ Cable length $\leq 3\text{m}$

Tab.27: Signal connector

Pin no.	Color <sup>1</sup>	Description	Level / state	
1	White	<u>Input</u> Analog speed setpoint setting	0...5V (see 12.4 Analog control voltage [► 71])	
2	Orange	<u>Input</u> UART	Tx <sup>3</sup> (see Tab. 29 [► 72])	
3	Black	GND <sup>2</sup>	0V	
4	Yellow	<u>Output</u> UART	Rx <sup>3</sup> (see Tab. 29 [► 72])	
5	Gray	<u>Output</u> 5V	5V (± 10%, max. 50 mA)	
6	Blue	<u>Input</u> PWM speed setpoint setting	LVTTL <sup>3</sup> 1...99% (100 Hz-5 kHz)	
7	Green	<u>Input</u> Remote ON/OFF	Off <sup>3</sup> = Logical 1 On = Logical 0	
8	Brown	GND <sup>2</sup>		
9	Red	<u>Output</u> Speed feedback	PWM LVTTL <sup>3</sup> 1...99% 1kHz	Upon customer request, parameterizable as speedo output: 6 or 60 pulses per revolution
10	Violet	<u>Output</u> Error signal	Error = Logical 1 No error = Logical 0	
If no supply voltage is present, the inputs must be potential-free!				

*Tab.28: Assignment of control cable connection*

<sup>1</sup> Color assignment - KNF standard control cable ID: 322551

<sup>2</sup> GND potential internally connected

<sup>3</sup> All digital signals are LVTTL (3.3 V);

*The signal direction is defined from the application to the pump.*

*The Rx and Tx designations are a matter of definition, depending on how the motor is defined as a device (as DTE or DCE; see TIA/EIA-232-F conformance). Furthermore, the device which the motor communicates with (from the customer's point of view) is also a matter of definition.*

## 12.4 Analog control voltage

The speed of the pump is scaled directly proportionally to the control voltage as follows:

- minimum speed = minimum control voltage of 0.1 V,
- maximum speed = maximum control voltage of 5.0 V.

If the control voltage is below 0.1 V, by default the pump remains OFF.

### Optional settings

Upon request, the following settings can be altered by the manufacturer:

- Changing the minimum and maximum values for control voltage in the range from 0...5 V,
- Behavior of the pump when control voltage falls below the minimum value:
  - Pump stops **or**
  - Pump continues working at minimum speed. In this case, the pump can only be switched off via REMOTE ON/OFF (Table\_Assignment of control cable connection/**Pin 7**).
- The lower and upper speed limits can be parameterized within the permissible range according to the customer's requirements.

## 12.5 PWM setpoint setting

The PWM signal can be set according to the values from Table\_Assignment of control cable connection. The signal is directly proportional to the speed: 1% PWM means minimum speed of the pump and 99% of the maximum speed.

If two signals for the speed setting are present at the same time: at pin 6 as PWM signal and at pin 1 as analog signal, the PWM signal is taken as the setpoint and the analog signal is ignored.

## 12.6 Digital setpoint setting

### Interface configuration

Designation	Value
Baud rate	57600 bits/s
Data bits	8
Parity	none
Stop bits	1
Flow control	none

*Tab. 29: Settings of the UART interface*

### Interface protocol

Tables *Tab. 30 [▶ 73]* to *Tab. 32 [▶ 75]* contain the command sets necessary for the interface protocol, expressed as ASCII characters. Each of the commands is to be terminated with <CR> (carriage return, decimal value 013). The answers from *Tab. 30 [▶ 73]* are symbols. The symbols are explained in *Tab. 32 [▶ 75]*.

There must be a pause of 25 ms between each UART command and the next command.

Input values are only processed by the controller as whole numbers (integers).

**UART protocol**

Parameter	Command	Function	Answer
Start	dU	Pump start	S ; E
Stop	dE	Pump stop	S ; E
Set speed setpoint	dSnnnn	Specify speed setpoint (nnnn = target speed in rpm in the range of nl and nh)	ns ; E
Status	pP	Readout of status values	ni ; ii ; ti ; ei (see 7 <i>Operation</i> [▶ 34]) ; E Actual speed; Cur- rent draw; Motor temperature; Status;
Status optional	gP	Status values (single value)	ei ; E
Read speed setpoint	gS	Readout of current speed setpoint	ns ; E
Minimum speed setpoint	gSl	Readout of the parameters for minimum speed	nl ; E
Maximum speed setpoint	gSh	Readout of the parameters for maximum speed	nh ; E
Firmware version number	iV	Readout of firmware version	V ; E

Tab.30: UART protocol

**Example of pump actuation**

Command	Pump response
dU <CR>	Start of pump (e.g. 2000 rpm)
dS1200 <CR>	Change of pump speed to 1200 rpm
pP <CR>	Output of the current status message of the motor (actual speed, current draw, motor temperature, status)
dE <CR>	Stop of pump

Tab.31: Example of pump actuation



If the setpoint is set digitally via UART, errors can be acknowledged directly with the command on the interface. For this, the command "dB" must be sent. Then, all errors that occurred are acknowledged.

For further information, please contact KNF Customer Service ([www.knf.com](http://www.knf.com)).

Symbol	Description
E	Success report: 0 Command cannot be executed 1 Command executed ? Command not clear
S	Status message (Pump receives start command: S=1; Pump receives stop command: S=0) (For Service only)
V	Firmware version (example: 01.005;1)
ni	Actual speed in rpm
ns	Setpoint speed in rpm
nl	Parameters for minimum speed in rpm
nh	Parameters for maximum speed in rpm
ii	Current draw in mA
ti	Motor temperature in °C
ei	Status register (see Errors at motor controller)

Tab.32: Symbols

### Pump START

To start the pump, see chapter *Start parameters of the pump* [▶ 76].

**NOTICE! The factory setting for the pump when the operating voltage is supplied is OFF.**

Optionally, the pump can be parameterized such that when the operating voltage is supplied the pump starts immediately at a defined starting speed. This speed must be agreed with KNF in advance and must lie within the minimum and maximum speed range specific to the product.

## Setpoint speed

Setting of the pump speed within the maximum and minimum speed limits.

The following process parameters can be read out with the pump in both digital and analog modes:

- Actual and setpoint speeds
- Minimum and maximum speed limits
- Motor current
- Temperature of the motor
- Status values
- Firmware version number

## 12.7 Extended parameterization and functions of the pump [.29 version]

### Start parameters of the pump

**Remote ON/OFF** In order to control the ON and OFF behavior of the pump, the signal from the "Remote ON/OFF" pin (Table\_Assignment of control cable connection/**Pin 7**) can be parameterized. In this case, various signal states can be used to start and stop the pump. This parameter is set in different ways depending on how the pump receives its speed setpoint setting (analog inputs or via UART).

### With analog speed setpoint

**Starting behavior of pump (standard)** The pump responds in direct inverse proportion to the state of the "Remote ON/OFF" input. That is to say, when a "logical 1" is at the input, the pump is OFF, and when a "logical 0" is at the "Remote ON/OFF" input, the pump is ON.

**Starting behavior of pump (optional)** **i** All pump starting behaviors marked "Optional" must be parameterized by KNF.

After the supply voltage is switched on, the pump does not start until a falling edge (from logical 1 to logical 0) is measured at the "Remote ON/OFF" input (Table\_Assignment of control cable connection/**Pin 7**). The pump is switched off at a rising edge.

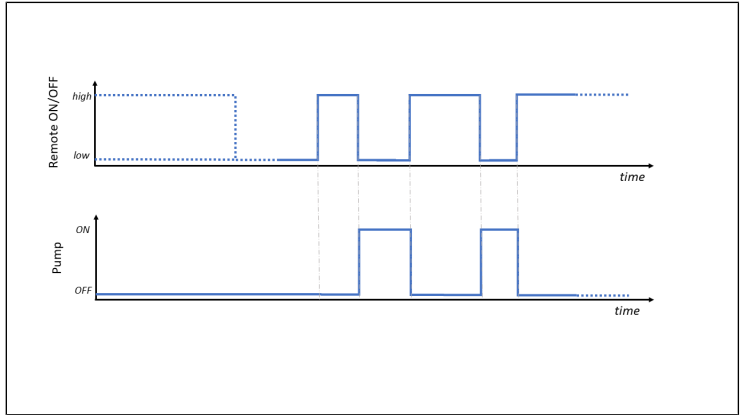

Fig. 26: Analog speed setpoint setting, Pump start: OFF

Starting behavior of pump: TOGGLE (optional)

When the supply voltage to the pump is switched on, the state of the "Remote ON/OFF" is taught in. In this process, the current state of the "Remote ON/OFF" level is defined as the new state for Pump OFF – see figure below.

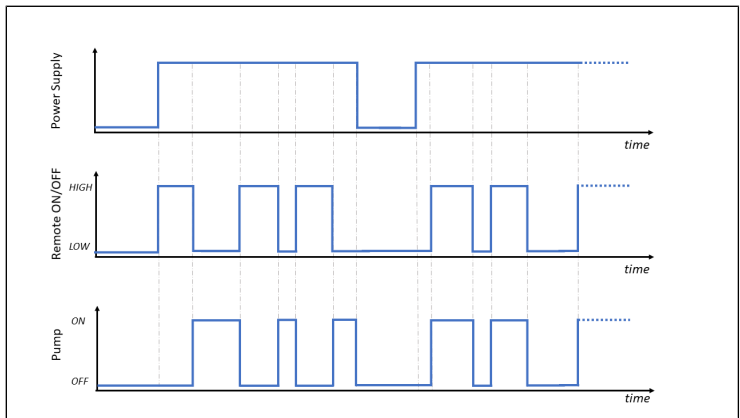

Fig. 27: Analog speed setpoint setting, Pump start: TOGGLE

Starting behavior of pump: LOCAL (optional)

The pump ignores the "Remote ON/OFF" signal. The pump can be stopped by allowing the analog control voltage to fall below its minimum value.

**NOTICE! The optional "Remote RESET" function is disabled for this setting.**

## 12.8 Motor accessories

Description	KNF order number
Power cable with pre-assembled connector and length of 300 mm	322555
Signal cable with pre-assembled connector and length of 300 mm	346564
RS232 adapter cable with 9-pin S-sub connector	Upon request
UART-USB transceiver cable	Upon request

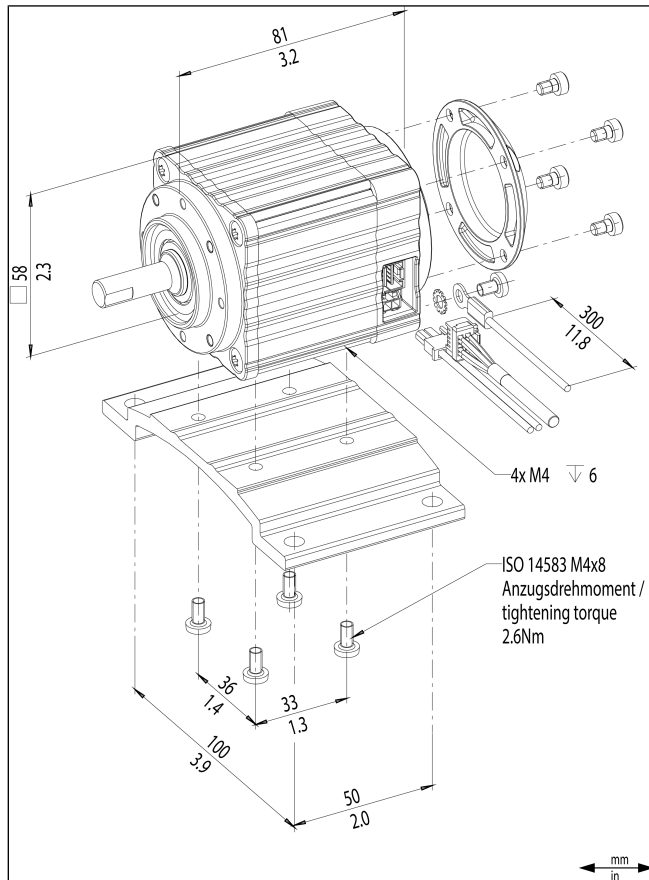

Fig.28: Motor accessories

## 12.9 Troubleshooting

### Display of the errors at the motor controller

Exceeding the overcurrent limit, exceeding the maximum temperature for the motor control board, or blockage of the rotor are displayed as errors.

The manufacturer only provides for logic 1 or 0 via a voltage at the fault output.

To clear the fault, the drive must be disconnected from the supply voltage.

Optional setting:

Upon request, the Remote RESET function can be parameterized by KNF.

## **13 Appendix: China RoHS**

**For further information, see also**

- [KNF Statement on China RoHS.pdf](#)

## SJ-T 11364-2024 Hazardous Substance Disclosure Table / SJ-T 11364-2024 有害物质含量表

This declaration is valid for the KNF products produced by:

本声明适用于由以下KNF公司生产的产品：

KNF Neuberger GmbH

DE-79112 Freiburg

Germany

The following information has been made available to comply with SJ-T 11364-2024 the Marking for Control of Pollution Caused by Electronic Information Products as required by China's Management Methods for the Control of Pollution from Electronic and Electrical Products.

提供以下信息旨在遵守中国《电子信息产品污染控制管理办法》所要求的 SJ-T 11364-2024《电子信息产品污染控制标识》标准。

Part Name 部件名称	Hazardous Substances Table 有害物质含量表						EFUP / 环境友好使用期限 	China RoHS comment / 中国RoHS注释	EU RoHS compliant / 符合欧盟RoHS指令
	Lead (Pb)	Mercury (Hg)	Cadmium (Cd)	Hexavalent Chromium (Cr(VI))	Polybrominated biphenyls (PBB)	Polybrominated diphenyl ethers (PBDE)			
Pump head / 泵头	X	O	O	O	O	O	20	Lead within EU RoHS exemption limit / 铅含量在欧盟RoHS豁免限值以内	Yes / 是
Pump housing / 泵体	X	O	O	O	O	O	20	Lead within EU RoHS exemption limit / 铅含量在欧盟RoHS豁免限值以内	Yes / 是
Pump motor / 泵的电机	X	O	O	O	O	O	20	Lead within EU RoHS exemption limit / 铅含量在欧盟RoHS豁免限值以内	Yes / 是
Additional components for systems / 系统附加部件	X	O	O	O	O	O	20	Lead within EU RoHS exemption limit / 铅含量在欧盟RoHS豁免限值以内	Yes / 是
<p>O: Indicates that this toxic or hazardous substance contained in all of the homogeneous materials for this part is below the limit requirement in SJ-T 11364-2024. 表示该有害物质在该部件所有均质材料中的含量均在 SJ-T 11364-2024 规定的限量要求以下。</p> <p>X: Indicates that this toxic or hazardous substance contained in at least one of the homogeneous materials used for this part is above the limit requirement in SJ-T 11364-2024. 表示该有害物质至少在该部件的某一均质材料中的含量超出 SJ-T 11364-2024 规定的限量要求。</p> <p>EFUP /环境友好使用期限: Environment Friendly Using Period / 环境友好使用期</p>									





KNF Neuberger GmbH  
Alter Weg 3  
79112 Freiburg  
Germany  
Tel. +49 (0)7664/5909-0

E-mail:  
[info.freiburg@knf.com](mailto:info.freiburg@knf.com)  
[www.knf.com](http://www.knf.com)

**KNF worldwide**

You can find our local KNF partners at: [www.knf.com](http://www.knf.com)

