

# Operating and Installation Instructions

# **Swing Piston Compressors**

# **and Vacuum Pumps**

UNPK04DC Pressure

UNPK04DC Vacuum

UNPK04DCB Pressure

UNPK04DCB Vacuum

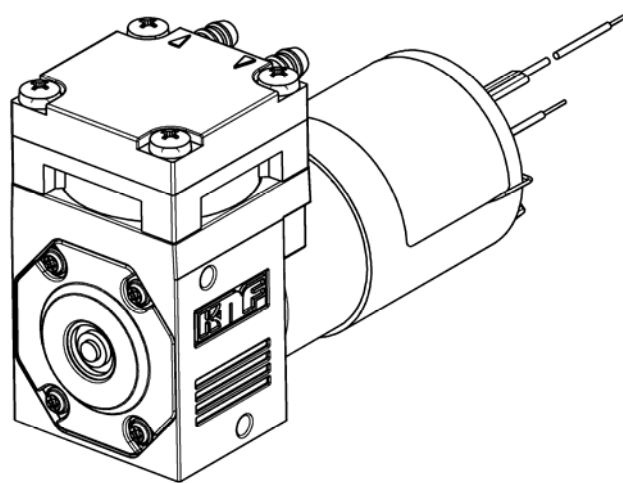

KNF Neuberger, Inc  
2 Black Forest Rd  
Trenton, NJ 08691-1810

Phone: 609-890-8600  
Fax: 609-890-8323

[www.knf.com/usa.htm](http://www.knf.com/usa.htm)

Ident#121571-125597  
Revision (09/12)

## Contents

## Page

1. About this document .....	2
2. Use .....	3
3. Safety.....	4
4. Technical Data .....	5
5. Installation and connection.....	6
6. Operation .....	8
7. Troubleshooting .....	9
8. Accessory .....	10
9. Product Return.....	11

# 1. About this document

## 1.1. Using the Operating and Installation Instructions

The Operating and Installation Instructions are part of the pump.

- ➔ Pass on the Operating and Installation Instructions to the next owner.

Project pumps

Customer-specific project pumps (pump models which begin with "PU" or "MPU") may differ from the Operating and Installation Instructions.

- ➔ For project pumps, also observe the agreed upon specifications.

## 1.2. Symbols and markings

### Warning



**WARNING**

A danger warning is located here.

Possible consequences of a failure to observe the warning are specified here. The signal word, e.g. Warning, indicates the danger level.

- ➔ Measures for avoiding the danger and its consequences are specified here.

### Danger levels

Signal word	Meaning	Consequences if not observed
<b>DANGER</b>	warns of immediate danger	Death or serious injuries and/or serious damage are the consequence.
<b>WARNING</b>	warns of possible danger	Death or serious injuries and/or serious damage are possible.
<b>CAUTION</b>	warns of a possibly dangerous situation	Minor injuries or damage are possible.

Tab. 1

### Other information and symbols

- ➔ An activity to be carried out (a step) is specified here.

1. The first step of an activity to be carried out is specified here. Additional, consecutively numbered steps follow.



This symbol refers to important information.

## 2. Use

### 2.1. Proper use

The pumps are designed for pumping air.

#### Owner's responsibility

Operating parameters and conditions

Only install and operate the pumps under the operating parameters and conditions described in Chapter 4, Technical data.

Only complete pumps may be taken into service.

Make sure that the installation location is dry and the pump is protected against rain, splash, hose and drip water.

Requirements for transferred medium

When using a medium other than air: Before using a medium, check whether the medium can be transferred danger-free in the specific application case.

Before using a medium, check the compatibility of the materials of the pump head, swing piston and piston seal with the medium.

### 2.2. Improper use



**WARNING**

Hazard of explosion when the surrounding atmosphere is explosive

→ The pumps may not be operated in an explosive atmosphere.



**WARNING**

Hazard of explosion from combustible and potentially explosive media

→ The pumps may not be used to pump combustible or potentially explosive media.

The pumps are not suitable for transferring dusts.

The pumps are not suitable for pumping vapors or liquids.

An overpressure must not be applied to the suction side of the pump.

### 3. Safety

**i** Note the safety precautions in sections 5. *Installation and connection*, and 6. *Operation*.

The pumps are built according to the generally recognized rules of technology and in accordance with the occupational safety and accident prevention regulations. Nevertheless, dangers can result during its use which leads to injuries to the user or others, or to damage to the pump or other property.

Only use the pumps in proper technical condition and in accordance with its intended use in a safety and danger-conscious manner while observing the Operating and Installation Instructions.

**Personnel** Make sure that only trained and instructed personnel or specially trained personnel work on the pump. This especially applies to assembly, connection and servicing work.

Make sure that the personnel has read and understood the Operating and Installation Instructions, and in particular the "Safety" chapter.

**Working in a safety-conscious manner** Observe the accident prevention and safety regulations when performing any work on the pump and during operation.

**Handling dangerous media** When transferring dangerous media, be sure to observe the safety regulations when handling these media.

**Environmental protection** Store all replacement parts in a protected manner and dispose of them properly in accordance with the applicable environmental protection regulations. Observe the respective national and international regulations. This especially applies to parts contaminated with toxic substances.

**EC Directives / Standards** For the purposes of the Machinery Directive 2006/42/EC, pumps are "partly completed machinery," and are therefore to be regarded as not ready for use. Partly completed machinery may not be commissioned until such time as it has been determined that the machine in which the partly completed machinery is to be assembled is in conformity with the provisions of the Machinery Directive 2006/42/EC. The essential requirements of Annex I of Directive 2006/42/EC (general principles) are applied and observed.



The pumps conform to the EC Directive 2004/108/EC concerning Electromagnetic Compatibility.

The following harmonized standards have been used:

UNPK04DC	UNPK04DCB
DIN EN 55014-1/2	DIN EN 55014-1
	DIN EN 61000-6-2

Tab. 2

**Customer service and repairs** Only have repairs to the pump carried out by the KNF Customer Service responsible.

## 4. Technical Data

### Pump materials

Assembly	Material
Head plate; cylinder	PPS
Valve plate	FPM
Piston seal	PTFE
O-ring	EPDM
Retainer plate	Aluminium

Tab. 3

\* according to DIN ISO 1629 and 1043.1

### Pneumatic values

UNPK04DC Vacuum

UNPK04DCB Vacuum

Parameter	Value
Max. permissible operating pressure [bar g]	-
Ultimate vacuum [mbar abs.]	300
Delivery rate at atm. pressure [l/min]*	3.3

Tab. 4

\*Liters in standard state (1,013 mbar)

UNPK04DC Pressure

UNPK04DCB Pressure

Parameter	Value
Max. permissible operating pressure [bar g]	1.0
Ultimate vacuum [mbar abs.]	-
Delivery rate at atm. pressure [l/min]*	3.3

Tab. 5

\*Liters in standard state (1,013 mbar)

### Electrical data

Parameter	Value
Electrical data	See type plate

Tab. 6

### Other parameters

Parameter	Values
Permissible ambient temperature	+ 5 °C bis + 40 °C
Permissible media temperature	+ 5 °C to + 40 °C
Gas-tightness	The gas-tightness of the pump is dependent on the medium used.*

Tab. 7

\* If you have questions about this, please contact your KNF advisor.

## 5. Installation and connection

Only install and operate the pump under the operating parameters and conditions described in Chapter 4, Technical data.

Observe the safety precautions (see Chapter 3).

### 5.1. Installation

- Mounting dimensions → Before installation, store the pump at the installation location to bring it up to room temperature.
- Installation location → See the data sheet for the mounting dimensions.
- Make sure that the installation location is dry and the pump is protected against rain, splash, hose and drip water.
- Install the pump at the highest point in the system to prevent condensate from collecting in the pump head.
- Protect the pump from dust.
- Protect the pump from vibrations and jolts.

### 5.2. Electrical connection



**DANGER**

Extreme danger from electrical shock

- Only have the pump connected by an authorized specialist.
- Only have the pump connected when the power supply is disconnected.

- In the electrical installation, arrangements (complying with EN 60335-1) must be made for disconnecting the pump motor from the electrical supply.

#### Connecting pump

1. Compare the supply data with the data on the motor-plate. For operating current see type plate.

**i** The voltage must not vary by more than + 10% and - 10% from that shown on the type-plate.

For brushed dc motor lead wires connection:

- Red: V+
- Black: Ground

**Caution:** → **Incorrect lead wire connection will damage motor.**

For brushless dc motor lead wire connection:

- Red: V+
- Blue: Ground
- White: Voltage control 0-5 V DC (4 wire motor only)
- Green: Frequency output (4 wire motor only)

**Caution:** → **Incorrect lead wire connection will damage motor.**

### EMC-compatible Installation (brushless DC motor)

In order to remove the electrical interference according to EN 55014-1:1993 + A1:1997 all pumps with brushless DC motor (DC B) must be equipped with an additional electronic circuit. This electronic circuit has to be installed as close to the motor as possible.

The additional circuitry is not necessary if a voltage supply has a suppression of > 20 dB at 150 kHz and 0 dB at 1 MHz.

The supplemental circuit must be structured according to the following electrical diagram and the components defined therein in order to achieve the required level of suppression

C1:	Capacitor	1 $\mu\text{F}$
C2:	Capacitor	1000 $\mu\text{F}$
L1:	Choke coil	6 $\mu\text{H}$

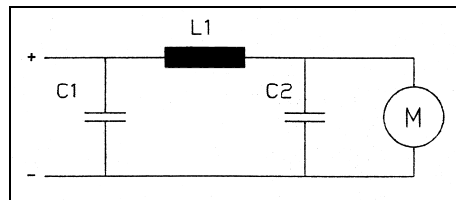

Fig. 1: Electrical diagram of the supplemental circuit

### 5.3. Pneumatic connection

- |                      |   |
|----------------------|---|
| Connected components | → Only connect components to the pump which are designed for the pneumatic data of the pump (see Chapter4, Technical data). |
| Pump exhaust         | → If the pump is used as a vacuum pump, safely discharge the pump exhaust.  |

#### Connecting pump

**i** A marking on the pump head shows the direction of flow.

1. Remove the protective plugs from the hose connectors.
2. The accessory silencer/filter (where applicable) is put onto the hose connector.
3. Connect the suction line and pressure line (tube ID 4 mm).
4. Lay the suction and pressure line at a downward angle to prevent condensate from running into the pump.

## 6. Operation

Only operate the pumps under the operating parameters and conditions described in Chapter 4, Technical data.

Make sure the pumps are used properly (see section 2.1).

Make sure the pumps are not used improperly (see section 2.2).

Observe the safety precautions (see Chapter 3).



### WARNING

Hazard of the pump head bursting due to excessive pressure increase

- Do not exceed max. permissible operating pressure (see Chapter 4, Technical data).
- Only throttle or regulate the air quantity (the gas quantity) in the suction line to prevent the maximum permissible operating pressure from being exceeded.
- If the air quantity (the gas quantity) in the pressure line is throttled or regulated, make sure that the maximum permissible operating pressure is not exceeded.
- Watch pressure during operation.
- If the pressure reaches the maximum permissible operating pressure of the pump, shut down pump and eliminate faults (see section 7).

**i** Excessive pressure (with all of the related hazards) can be prevented by placing a bypass line with a pressure-relief valve between the pressure and suction sides of the pump. For further information, contact our technical adviser (see front page for telephone number).

Pump standstill → With the pump at a standstill, open pressure and suction lines to normal atmospheric pressure.

Silencer/filter Change the silencer/filter (accessory) if it is dirty.

Switching pump on **i** The pump may not start up against pressure or vacuum during switch-on. This also applies in operation following a brief power failure.

→ Make sure that normal atmospheric pressure is present in the lines during switch-on.



## 7. Troubleshooting



Extreme danger from electrical shock!

→ Disconnect the pump power supply before working on the pump.

**DANGER** → Make sure the pump is deenergized and secure.

Check the pump (see Tab. 8 and 9).

<b>Pump does not transfer</b>	
Cause	Fault remedy
Connections or lines blocked.	→ Check connections and lines. → Remove blockage.
External valve is closed or filter is clogged.	→ Check external valves and filters.
Condensate has collected in pump head.	→ Install pump at highest point in system.
Piston seal or valve plates are worn.	→ Replace pump.

Tab. 8

<b>Flow rate, pressure or vacuum too low</b>	
The pump does not achieve the output specified in the Technical data or the data sheet.	
Cause	Fault remedy
Condensate has collected in pump head.	→ Install pump at highest point in system.
There is gauge pressure on pressure side and at the same time vacuum or a pressure above atmospheric pressure on suction side.	→ Change the pressure conditions.
Pneumatic lines or connection parts have an insufficient cross section.	→ Disconnect pump from system to determine output values. → Eliminate throttling (e.g. valve) if necessary. → Use lines or connection parts with larger cross section if necessary.
Leaks occur on connections, lines or pump head.	→ Eliminate leaks.
Connections or lines completely or partially jammed.	→ Check connections and lines. → Remove the jamming parts and particles.
Head parts are soiled.	→ Clean head components.
Piston seal or valve plates are worn.	→ Replace pump.

Tab. 9

### **Fault cannot be rectified**

If you are unable to determine any of the specified causes, send the pump to KNF Customer Service (see first page for the address).

## 8. Accessory

Accessories	Order No.
Silencer/filter	024805

Tab. 10

## 9. Product Return

- KNF provides warranty and non-warranty repair services for all products.
- A Return Material Authorization (RMA) number is required for all product returns.
  - To receive an RMA number, submit a completed Decontamination Declaration form to [rma@knf.com](mailto:rma@knf.com)
- The Decontamination Declaration form can be obtained from our website or by contacting KNF Technical Services.
  - <http://www.knf.com/pdfs/decontamdec.doc>
  - Phone: 609-890-8600
- Product return instructions will be provided when the RMA is issued.

KNF Neuberger, Inc  
2 Black Forest Rd  
Trenton, NJ 08691-1810

Phone 609-890-8600  
Fax 609-890-8323

[www.knf.com/usa.htm](http://www.knf.com/usa.htm)

